



**CITY OF PHOENIX
AVIATION DEPARTMENT**

**Amy Turner
Procurement Officer
2485 East Buckeye Road
Phoenix, AZ 85034
(602) 273-3349
Amy.m.turner@phoenix.gov**

**REQUEST FOR QUALIFICATIONS (RFQu)
AVN RFQu 23-021(AT)**

AIRLINE COMMON USE PAPER II



TABLE OF CONTENTS

**CITY OF PHOENIX
Aviation Department
Contracts & Services Division
2485 E. Buckeye Road
Phoenix, AZ 85034**

TABLE OF CONTENTS.....2

SOLICITATION RESPONSE CHECKLIST.....3

SECTION I – INSTRUCTIONS.....4

SECTION II – STANDARD TERMS AND CONDITIONS.....19

SECTION III – SPECIAL TERMS & CONDITIONS.....38

SECTION IV – INSURANCE AND INDEMNIFICATION.....44

SECTION V – SCOPE.....48

SECTION VI – SUBMITTALS.....57

SECTION VII – EXHIBITS.....67



SOLICITATION RESPONSE CHECKLIST

CITY OF PHOENIX
Aviation Department
Contracts & Services Division
2485 E. Buckeye Road
Phoenix, AZ 85034

Please read before continuing to the offer document. This list may not include every requirement; the purpose is to assist Offerors, but Offerors are expected to read and comply with the entire Solicitation.

SOLICITATION RESPONSE CHECK LIST

Check off each of the following as the necessary action is completed.

- All forms have been completed and signed, including Solicitation Disclosure form.
- All required Submittals are included.
- Included any required drawings or descriptive literature.
- Reviewed the insurance requirements, if any, to assure compliance.
- Included the specified number of copies of the offer as indicated in Submittal section if physical submission is elected.
- Included signed addenda, if any.
- If physical submission is elected address the mailing envelope to the Procurement Officer on the Solicitation front page, at the address listed.
- The mailing envelope clearly shows your company name and address, the Solicitation number, Solicitation title and the offer opening date, or if submitting electronically, include the Solicitation number and title on the email subject line.
- The response must be timely submitted – City must receive offers no later than the date and time indicated in the Schedule of Events or addenda.



SECTION I - INSTRUCTIONS

CITY OF PHOENIX
Aviation Department
Contracts & Services Division
2485 E. Buckeye Road
Phoenix, AZ 85034

SECTION I - INSTRUCTIONS

1. STATEMENT OF NEED:

The City of Phoenix Aviation Department invites sealed Statements of Qualifications from qualified Offerors to supply airline common use paper for Common Use Passenger Processing System (CUPPS) and Common Use Self-Serve (CUSS) system, including boarding pass paper, standard bag tags, thermal paper rolls, and RFID bag tags for check-in counters, kiosks, and gates for airlines at Phoenix Sky Harbor International Airport (Airport) on an as-needed basis.

The Aviation Department will establish a Qualified Vendor List (QVL) of Vendors that are deemed qualified to provide airline common use paper as described in this Solicitation. The Aviation Department will evaluate the Offerors on a pass or fail basis for each listed product qualification criteria. Only those Offerors that receive a pass for the proposed product may be recommended for a Contract. Offerors may submit Offers for one or more products.

The resultant Contract(s) will commence on or about February 1, 2022 for a five (5) year term in accordance with the specifications and provisions contained herein.

- 1.1. This Solicitation is available through Arizona Relay Service 7-1-1. Please call TTY 800-367-8939 for assistance.
- 1.2. Notwithstanding the foregoing, the QVL and associated contract(s) will terminate upon the earliest of the following occurrences: reaching the end of the term, including any extensions exercised; or termination pursuant to the provisions of this Contract.

2. CITY'S VENDOR SELF-REGISTRATION AND NOTIFICATION:

Offerors must be registered in the City's procurePHX Self-Registration System at <https://www.phoenix.gov/financesite/Pages/EProc-help.aspx> to respond to this Solicitation and access procurement information. The City may, at its sole discretion, reject any Offer from an Offeror who has not registered. The product categories for this QVL are as follows: 080690000 Tags: Luggage, Security, ID.



SECTION I - INSTRUCTIONS

CITY OF PHOENIX
Aviation Department
Contracts & Services Division
2485 E. Buckeye Road
Phoenix, AZ 85034

3. SCHEDULE OF EVENTS:

ACTIVITY (All times are local Phoenix time)	DATE	LOCATION
Solicitation Issue Date	October 21, 2022	City Solicitation Website
Pre-Offer Conference	N/A	N/A
Site Visit	N/A	N/A
Written Inquiries Due Date	October 27, 2022 by 3p.m. Phoenix time	amy.m.turner@phoenix.gov and avn.procurephx@phoenix.gov
Offer Due Date	November 10, 2022 by 11a.m. Phoenix time	<u>Physical Submission:</u> Aviation Headquarters Building 2485 East Buckeye Road, Phoenix, Arizona 85034 OR <u>Electronic Submission</u> refer to Paragraph 14 in this Section.
Offer Opening	November 10, 2022 at 11:05 a.m.	To join the meeting please click on the below link: https://cityofphoenix.webex.com/cityofphoenix/j.php?MTID=md94d0f9de1b408a85620054ca398a9af Join by phone +1-415-655-0001 US Toll Access code: 2455 169 1158

The City reserves the right to change dates, times, and locations as necessary. The City does not always hold a pre-offer conference or site visit.

4. SUBMISSION OF OFFER – HARD COPY SUBMISSION:

Offers must be in the possession of the Aviation Department on or prior to the exact time and date indicated in the Schedule of Events. Late Offers will not be considered. The prevailing clock will be the City Aviation Department's clock.



SECTION I - INSTRUCTIONS

CITY OF PHOENIX
Aviation Department
Contracts & Services Division
2485 E. Buckeye Road
Phoenix, AZ 85034

Offers must be submitted in a sealed envelope and the following information should be noted on the outside of the envelope:

- Offeror's Name
- Offeror's Address (as shown on the Certification Page)
- Solicitation Number
- Solicitation Title
- Offer Opening Date

All Offers must be completed in ink or typewritten. Unless submitted electronically, include the number of copies that are required as indicated in the Submittal section.

For "In-Person" and "via Carrier (i.e. USPS, FedEx, UPS, etc.)" Delivery: Offers will be received at the Aviation Headquarters Building located at 2485 East Buckeye Road, Phoenix AZ 85034 in the LOBBY during normal business hours (8:00 am – 5:00 pm Phoenix, AZ time). Offers should be clearly identified outside of the package as designated above.

If you are using a third-party shipping company (USPS, FedEx, UPS, etc.) to submit via Carrier delivery, please make sure to confirm with the third-party delivery service provider that the delivery will not be affected by changes resulting from COVID-19. Offerors are responsible for managing potential delays due to COVID-19. The City does not make exceptions for delays caused by the Carrier. It is Offeror's responsibility to ensure that the Offer is timely submitted.

5. SUBMISSION OF OFFER – ELECTRONIC SUBMISSION:

Due to the national COVID-19 pandemic, the Aviation Department is accepting electronic Offers for this Solicitation, in addition to other methods of submitting sealed offer packages (hard copies). Offerors are responsible for submitting the electronic Offer on or before the Solicitation Deadline. **For "Electronic" Submittal:** Offers must be submitted via email to avn.procurephx@phoenix.gov AND amy.m.turner@phoenix.gov. Due to file size limitations of 100mb for electronic transmission (for sending or receiving), Offers sent by email may need to be sent in parts with multiple emails. The date and time on the email(s) as received/stamped by the City's inbox will provide proof of submission and verification whether the Offer (including all parts if sent in multiple emails) was received on or before the Solicitation Deadline. The Solicitation number and title "**AVN RFQu 23-021 Airline Common Use Paper II**" must be included on the subject line of the email when submitting an Offer.



SECTION I - INSTRUCTIONS

CITY OF PHOENIX
Aviation Department
Contracts & Services Division
2485 E. Buckeye Road
Phoenix, AZ 85034

Offerors may submit electronic signatures on documents that do not require notarization. Please ensure that electronically signed documents are submitted in separate pdf files. The City does not accept electronic signatures for notarized documents, including bonds, guaranties, powers of attorney, or affidavits. These documents must be submitted in paper form (hard copy) with original or “wet-ink signatures” at time of the Solicitation Deadline and submission must comply with the hard copy submission requirements in Paragraph 4.

It is the responsibility of Offerors to ensure that their Offers are timely, including confirming that there are no technical reasons that any Offer submitted electronically may be delayed.

6. PREPARATION OF OFFER:

- 6.1.** All forms provided in Submittal Section must be completed and submitted with the Offer. The signed and completed Solicitation Disclosure form must be included, or your Offer may be deemed non-responsive.
- 6.2.** It is permissible to copy Submittal forms if necessary. Erasures, interlineations, or other modifications of the Offer must be initialed in original ink by the authorized person signing the offer. No Offer will be altered, amended, or withdrawn after the specified Offer due date and time. The City is not responsible for Offerors’ errors or omissions.
- 6.3.** All time periods stated as a number of days are calendar days.
- 6.4.** It is the responsibility of Offerors to examine the entire Solicitation and seek clarification of any requirement that may not be clear and to check all responses for accuracy before submitting an offer. Negligence in preparing an offer confers to right of withdrawal after due date and time. Offerors are strongly encouraged to:
 - 6.4.1.** Consider applicable laws and/or economic conditions that may affect cost, progress, performance, or furnishing of the products or services.
 - 6.4.2.** Study and carefully correlate Offeror’s knowledge and observations with the Solicitation and other related data.
 - 6.4.3.** Promptly notify the City of all conflicts, errors, ambiguities, or discrepancies that Offeror has discovered in or between the Solicitation and other related documents.



SECTION I - INSTRUCTIONS

CITY OF PHOENIX
Aviation Department
Contracts & Services Division
2485 E. Buckeye Road
Phoenix, AZ 85034

- 6.4.4.** The City does not reimburse the cost of developing, presenting or providing any response to this Solicitation. Offers submitted for consideration should be prepared simply and economically, providing adequate information in a straightforward and concise manner. Offerors are responsible for all costs incurred in responding to this Solicitation. All materials and documents submitted in response to this Solicitation become the property of the City and will not be returned.
- 6.4.5.** Offerors are reminded that the specifications stated in the Solicitation are the minimum level required and that Offers submitted must be for products or services that meet or exceed the minimum level of all features specifically listed in this Solicitation. Offers offering less than any minimum specifications or criteria specified are not responsive and should not be submitted.
- 6.4.6.** Offers submitted for products considered by the seller to be acceptable alternates to the brand names or manufacturer's catalog references specified herein must be submitted with technical literature and/or detailed product brochures for the City's use to evaluate the products offered. Offers submitted without this product information may be considered as non-responsive and rejected. The City will be the sole judge as to the acceptability of alternate products offered.

7. OBTAINING A COPY OF THE SOLICITATION AND ADDENDA:

Offerors may download the complete Solicitation and addenda from <https://Solicitations.phoenix.gov/>. Internet access is available at all public libraries. Offerors without internet access may obtain this Solicitation by calling the Procurement Officer or picking up a copy during regular business hours at the City of Phoenix, Aviation Department, Contracts and Services Division, 2485 East Buckeye Road, Phoenix, AZ, 85034. It is each Offeror's responsibility to check the website, read the entire Solicitation, and verify all required information is submitted with their Offers.

8. EXCEPTIONS:

Offerors must not take any exceptions to any terms, conditions, or material requirements of this Solicitation. Offers submitted with exceptions may be deemed non-responsive and disqualified from further consideration in the City's sole discretion. Offerors must conform to all the requirements specified in the Solicitation. The City encourages Offerors to send inquiries to the Procurement Officer rather than including exceptions in their Offer.



SECTION I - INSTRUCTIONS

CITY OF PHOENIX
Aviation Department
Contracts & Services Division
2485 E. Buckeye Road
Phoenix, AZ 85034

9. INQUIRIES:

- 9.1. All questions that arise relating to this Solicitation should be directed via email to the Procurement Officer and must be received by the due date indicated in the Schedule of Events. The City will not consider questions received after the deadline.
- 9.2. No informal contact initiated by Offerors on the proposed service will be allowed with members of City's staff from date of distribution of this Solicitation until after the resulting Contract(s) are awarded or responses are rejected, and the Solicitation is cancelled without any announcement by the Procurement Officer of the City's intent to reissue the same or similar Solicitation. All questions concerning, or issues related to this Solicitation must be presented in writing.
- 9.3. The Procurement Officer will answer written inquiries in an addendum and publish any addenda on the Procurement Website.

10. ADDENDA:

The City will not be responsible for any oral instructions made by any employees or officers of the City regarding this Solicitation. Any changes will be in the form of an addendum. **Offerors must acknowledge receipt of any/all addenda by signing and returning the document with the Offer submittal. Failure to acknowledge receipt and return a signed addendum may result in the rejection of Offer as non-responsive.**

11. BUSINESS IN ARIZONA:

The City will not enter into contracts with Offerors (or any company(ies)) not granted authority to transact business, or not in good standing, in the state of Arizona by the Arizona Corporation Commission, unless the Offeror asserts a statutory exception prior to entering into a Contract with the City.

12. LICENSES:

If required by law for the operation of the business or work related to this Offer, Offerors must possess all valid certifications and licenses required by federal, state, or local laws at the time of submittal.

13. CERTIFICATION:

By signature in the offer section of the Offer and Acceptance page(s), Offeror certifies:

- 13.1. The submission of the Offer did not involve collusion or other anti-competitive practices.



SECTION I - INSTRUCTIONS

CITY OF PHOENIX
Aviation Department
Contracts & Services Division
2485 E. Buckeye Road
Phoenix, AZ 85034

13.2. Offeror must not discriminate against any employee or applicant for employment in violation of federal or state law.

13.3. Offeror has not given, offered to give, nor intends to give at any time hereafter any economic opportunity, future employment, gift, loan, gratuity, special discount, trip, favor, or service to a public servant in connection with the submitted Offer.

14. WITHDRAWAL OF OFFER:

At any time prior to the Solicitation due date and time, an Offeror (or designated representative) may withdraw the Offer by submitting a request in writing and signed by a duly authorized representative.

15. OFFER RESULTS:

Offers will be opened on the offer due date, time and location indicated in the Schedule of Events, at which time the name of each Offeror may be read. Offers and other information received in response to the Solicitation will be shown only to authorized City personnel having a legitimate interest in them or persons assisting the City in the evaluation. Offers are not available for public inspection until after the City has posted the award recommendation on the City's website.

The City will post Offerors' names on the City's website, <https://Solicitations.phoenix.gov/Awards> within five calendar days of the offer opening. After the City has evaluated the Offers, the City will post an award recommendation on the website. The City will not provide any further notification to unsuccessful Offerors.

16. QUALIFICATION CRITERIA:

Offers shall relate specifically to the following items, listed in general order of importance, for evaluation and selection purposes. Offerors must demonstrate in the offer that they meet all the Qualification Criteria as defined below and the City will verify that Offeror meets the Qualification Criteria through the Offeror's references submitted in Section VI - Submittals. Offerors may not use subcontractor experience and qualifications to meet the Qualification Criteria.



SECTION I - INSTRUCTIONS

CITY OF PHOENIX
Aviation Department
Contracts & Services Division
2485 E. Buckeye Road
Phoenix, AZ 85034

16.1. OFFEROR EXPERIENCE:

Offeror must have been in operation for a minimum of **five (5) consecutive years within the last ten (10) years immediately preceding issuance of this RFQu**, in supplying various types of airline common use paper and tags that comply with the International Air Travel Association (IATA) specification(s) and requirements in this RFQu in a facility(ies) and/or environment that operates 24/7, 365 days per year. The “Experience” qualification will also be verified through the references provided in the Business References in the Submittal Section of this solicitation.

16.2. SERVICE REPRESENTATIVE:

Offerors must assign a service representative who will be the City’s primary contact under the resultant Contract.

16.2.1. Qualifications: Offeror’s assigned service representative must possess a minimum of two (2) years’ experience in providing airline common use paper to airport customers. A copy of a resume (not to exceed 2 pages, double-sided) for the proposed service representative must be submitted at the time of Offer submittal.

16.2.2. Offeror’s assigned service representative may not be changed during the course of the solicitation process, including the time up to Contract award. After Contract award, the assigned service representative may only be changed with the Aviation Department Representative (ADR)’s approval. A resume of the proposed replacement service representative must be submitted to the ADR for prior approval.

17. CONTENT OF RESPONSE:

Offerors’ responses must include the following:

17.1. STATEMENT OF QUALIFICATIONS: A Statement of Qualifications must be provided that presents an Executive Summary of company history, background, and experience as it relates to providing airline common use paper per the specifications in paragraph 16 and Section V-Scope of work, and address information listed below that is related to the services indicated in this Solicitation.

17.1.1. Offerors must provide an Executive Summary, not to exceed two (2) pages (double-sided), describing how Offeror meets the minimum qualifications specified in paragraph 16, including:



SECTION I - INSTRUCTIONS

CITY OF PHOENIX
Aviation Department
Contracts & Services Division
2485 E. Buckeye Road
Phoenix, AZ 85034

- (a) Describe Offeror's experience (including years of experience as described in paragraph 16.1.) in manufacturing and/or supplying airline common use paper to airport customers.
- (b) List all contracts Offeror has had and/or currently having that are related to the service scope of this Solicitation. Offeror must include each contract period and service scope/activities provided for each contract.

17.2. METHOD OF APPROACH: A Method of Approach must be provided that describes how products will be provided to the City for airline common use paper per Section V-Scope. The Method of Approach is limited to not exceed two (2) pages. Method of Approach should include:

- 17.2.1. Delivery method
- 17.2.2. Delivery times (shipments to be accepted)
- 17.2.3. Lead time (between order and delivery)
- 17.2.4. Availability

17.3. Service Representative resume (not to exceed 2 pages, double-sided) for the proposed service representative.

17.4. SAMPLES:

- 17.4.1. Offerors shall provide a sample for each of the proposed products to be supplied under the resultant Contract at no cost to the City along with the submittal package to be evaluated for the intended offered product. Failure to provide a sample with the Offer may result in rejection of the Offer for non-responsiveness. Any sample(s) submitted shall create an express warranty that the whole of the goods shall conform to the sample submitted. All samples become the property of the City.
- 17.4.2. Any sample(s) submitted shall create an express warranty the whole of the goods shall conform to the sample submitted for the proposed products. For Offerors who are submitting for the following three (3) products, please ensure to have the sample comply with the quantity(ies) identified below.



SECTION I - INSTRUCTIONS

CITY OF PHOENIX
Aviation Department
Contracts & Services Division
2485 E. Buckeye Road
Phoenix, AZ 85034

Required Sample Type	Quantity
Generic Boarding Passes	10 feet
Bag Tag(s)	10 feet for each type
Kiosks Boarding Passes	3 feet
Thermal Paper	3 feet

17.5. Complete and include all of Section VI, Submittals.

18. PRE-AWARD SURVEY:

The City reserves the right to perform or to have performed necessary survey of Offeror's facilities or previous work products and to investigate its other capabilities. This survey will serve to verify the data and representation submitted, and to determine that Offeror has overall capability adequate to meet the Contract requirements.

19. EVALUATION AND SELECTION:

19.1. In accordance with Administrative Regulation 3.10, Qualifications Based Selection, a list of qualified Offerors will be established based on the qualification criteria detailed in Section I paragraph 16 of this RFQu. The City will evaluate the Offerors as pass or fail for each qualification criteria and only those Offerors that receive a pass for all qualification criteria may be recommended for the QVL.

19.2. The Offerors under consideration for this RFQu, will be evaluated by the Procurement Officer. The City reserves the right to request clarification information that the Procurement Officer deems necessary to make a recommendation to establish a QVL. The Procurement Officer's review may be supplemented by subject matter experts, outside professionals, or professionals from other City departments who can provide additional expertise.

19.3. Upon completion of the evaluation process and in accordance with Administrative Regulation 3.10, the City may establish a QVL and may issue resultant requests for quotes for orders to the selected candidates and may issue resultant purchase orders to the lowest bidder based on price and delivery time. The City will develop the order of the QVL based on the order that the responses are received. Placement on any QVL established by the City does not represent or guarantee that orders will be placed, but rather an option to request materials at the City's discretion.

19.4. RFQu responses should be concise, well-organized per the requested information, clearly written, and limited to no more than two (2) pages double-sided. The review process places considerable emphasis on the responsiveness of the RFQu Offers to the requirements outlined above. RFQu responses that are not written specifically in response to this RFQu cannot receive serious consideration.



SECTION I - INSTRUCTIONS

CITY OF PHOENIX
Aviation Department
Contracts & Services Division
2485 E. Buckeye Road
Phoenix, AZ 85034

20. AGREEMENT:

20.1. The City may require the selected Offeror to participate in negotiations and to submit such cost, technical, or other revisions of the Offers as may result from negotiations. The City shall draft all final contracts and documents that result from this RFQu.

20.2. The language contained in this RFQu and the Offeror's Statement of Qualifications will form the basis of any resulting Contract. However, this RFQu does not commit the City to enter a Contract, to pay any costs incurred in the preparation of a submittal to this request or in subsequent negotiations, or to procure a Contract for the project(s).

21. CITY'S RIGHT TO DISQUALIFY FOR CONFLICT OF INTEREST:

The City reserves the right to disqualify any Offeror based on any real or apparent conflict of interest that is disclosed by the Offer submitted or any other data available to the City. This disqualification is at the sole discretion of the City. Any Offeror submitting an Offer waives any right to object now or at any future time, before any agency or body, including but not limited to, the City Council of the City of Phoenix or any court.

22. SOLICITATION TRANSPARENCY POLICY:

22.1. Commencing on the date and time a Solicitation is published, potential or actual Offerors or respondents (including their representatives) shall only discuss matters associated with the Solicitation with the Mayor, any members of City Council, the City Manager, any Deputy City Manager, or any department director directly associated with the Solicitation (including in each case their assigned staff, except for the designated procurement officer) at a public meeting, posted under Arizona Statutes, until the resulting Contract(s) are awarded to all Offers or responses are rejected and the Solicitation is cancelled without any announcement by the Procurement Officer of the City's intent to reissue the same or similar Solicitation.

22.2. As long as the Solicitation is not discussed, Offerors may continue to conduct business with the City and discuss business that is unrelated to the Solicitation with the City staff. Offerors may not discuss the Solicitation with any City employees or evaluation panel members.

22.3. Offerors may discuss their Offer or the Solicitation with the Mayor or one or more members of the Phoenix City Council, provided such meetings are scheduled through the Procurement Officer and are posted as open meetings with the City Clerk at least 24 hours prior to the scheduled meetings. The City Clerk will be responsible for posting the meetings. The posted notice shall identify the participants and the subject matter, as well as invite the public to participate.



SECTION I - INSTRUCTIONS

CITY OF PHOENIX
Aviation Department
Contracts & Services Division
2485 E. Buckeye Road
Phoenix, AZ 85034

- 22.4.** With respect to the selection of the successful Offerors, the City Manager and/or City Manager's Office will continue the past practice of exerting no undue influence on the process. In all Solicitations of bids and proposals, any direction on the selection from the City Manager and/or City Manager's Office and Aviation Department Head (or representative) to the proposal review panel or selecting authority must be provided in writing to all prospective Offerors.
- 22.5.** This policy is intended to create a level playing field for all Offerors, assure that Contracts are awarded in public, and protect the integrity of the selection process. **OFFERORS THAT VIOLATE THIS POLICY SHALL BE DISQUALIFIED.** After official Notice is received by the City for disqualification, the Offeror may follow the Protest process, unless the Solicitation is cancelled without notice of intent to re-issue.
- 22.6.** "To discuss" means any contact by the Offeror, regardless of whether the City responds to the contact. Offerors that violate this policy will be disqualified until the resulting Contract(s) are awarded, or all Offers, or responses are rejected, and the Solicitation is cancelled without any announcement by the Procurement Officer of the City's intent to reissue the same or a similar Solicitation. The City interprets the policy as continuing through a cancellation of a Solicitation until Council award of the Contract, as long as the City cancels with a statement that the City will rebid the Solicitation.

23. PROTEST PROCESS:

- 23.1.** Offerors may protest the contents of a Solicitation no later than seven days before the Solicitation deadline when the protest is based on an apparent alleged mistake, impropriety or defect in the Solicitation. Protests filed regarding the Solicitation may be addressed by an addendum to the Solicitation or denied by the City. If denied, the opening and award will proceed unless the City determines that it is in the City's best interests to set new deadlines, amend the Solicitation, cancel or re-bid.
- 23.2.** Therefore, unless otherwise notified by a formal amendment, the protester must adhere to all Solicitation dates and deadlines, including timely filing of an Offer, regardless of filing a protest.
- 23.3.** Offerors may protest an adverse determination issued by the City regarding responsibility and responsiveness, within seven days of the date the Offeror was notified of the adverse determination.



SECTION I - INSTRUCTIONS

CITY OF PHOENIX
Aviation Department
Contracts & Services Division
2485 E. Buckeye Road
Phoenix, AZ 85034

- 23.4.** Offerors may protest an award recommendation if the Offeror can establish that it had a substantial chance of being awarded the Contract and will be harmed by the recommended award. The City will post recommendations on the City's website to award the Contract(s) to an Offeror. Offeror must submit award protests within seven days after the posting of the award recommendation, with exceptions only for good cause shown, within the City's full and final discretion.
- 23.5.** All protests will be in writing, filed with the Procurement Officer identified in the Solicitation and include the following:
- 23.5.1.** Identification of the Solicitation number;
 - 23.5.2.** The name, address and telephone number of the protester;
 - 23.5.3.** A detailed statement describing the legal and factual grounds for the protest, including copies of relevant documents;
 - 23.5.4.** The form of relief requested; and
 - 23.5.5.** The signature of the protester or its authorized representative.
- 23.6.** The Procurement Officer will render a written decision within a reasonable period after the protest is filed. The City will not request City Council authorization to award the Contract until the protest process is complete. All protests and appeals must be submitted in accordance with the City's Procurement Code, (Phoenix City Code, Ch. 43) and any protests or appeals not submitted within the time requirements will not be considered. Protests must be filed with the Procurement Officer.

24. PUBLIC RECORD:

All Offers submitted in response to this Solicitation will become the property of the City and become a matter of public record available for review pursuant to Arizona law. If an Offeror believes that a specific section of its Offer response is confidential, then Offeror must isolate the pages marked confidential in a specific and clearly labeled section of its Offer. An Offeror may request specific information contained within its Offer is treated by the Procurement Officer as confidential provided the Offeror clearly labels the information "confidential." To the extent necessary for the evaluation process, information marked as "confidential" will not be treated as confidential. Once the procurement file becomes available for public inspection, the Procurement Officer will not make any information identified by the Offerors as "confidential" available to the public unless necessary to support the evaluation process or if specifically requested in accordance with applicable public records law. When a public records request for such information is received, the Procurement Officer will notify the Offeror in writing of any request to view any portion of its Offer marked "confidential." The Offeror will have the time set forth in the notice to obtain a court order enjoining such disclosure. If the Offeror does not provide the Procurement Officer with a court order enjoining release of the information during the designated time, the Procurement Officer will make the information requested available for inspection.



SECTION I - INSTRUCTIONS

CITY OF PHOENIX
Aviation Department
Contracts & Services Division
2485 E. Buckeye Road
Phoenix, AZ 85034

25. LATE OFFERS:

Late Offers must be rejected, except for good cause. If a late Offer is submitted, the Aviation Department will document the date and time of the submittal of the late Offer, keep the Offer and notify the Offeror that its Offer was disqualified for being late.

26. RIGHT TO DISQUALIFY:

The City reserves the right to disqualify any Offeror who fails to provide information or data requested or who provides materially inaccurate or misleading information or data. The City further reserves the right to disqualify any Offeror on the basis of any real or apparent conflict of interest that is disclosed by the Offeror submitted or any other data or information available to the City. This disqualification is at the sole discretion of the City. By submission of a Solicitation response, Offeror waives any right to object now or at any future time, before any agency or body, including, but not limited to, the City Council of the City or any court as to the exercise by the City of such right to disqualify or as to any disqualification by reason of real or apparent conflict of interest determined by the City. The City reserves the right to replace the disqualified Offeror.

27. CONTRACT AWARD:

The City reserves the right to award a Contract by individual line items, by group, all or none, or any other combination most advantageous to the City. The City reserves the right to multiple awards.

28. DETERMINING RESPONSIVENESS AND RESPONSIBILITY:

28.1. Offers will be reviewed for documentation of minimum qualifications, completeness, and compliance with the Solicitation requirements. The City reserves sole discretion to determine responsiveness and responsibility.

28.2. Responsiveness: Non-responsive Offers will not be considered in the evaluation process. The Solicitation states criteria that determine responsiveness, and the Solicitation includes terms and conditions that if included or excluded from Offers (as the case may be) will render an Offer non-responsive.

28.3. Exceptions, conditions, reservations, or understandings are presumed to be unacceptable, and an Offer that includes unacceptable exceptions, conditions, reservations, or understandings may be rejected as nonresponsive. Alternatively, the City in its sole discretion may instruct in writing that any Offeror remove the conditions, exceptions, reservations, or understandings. If the Offeror fails to do so in writing, the City may determine the Offer to be nonresponsive.



SECTION I - INSTRUCTIONS

CITY OF PHOENIX
Aviation Department
Contracts & Services Division
2485 E. Buckeye Road
Phoenix, AZ 85034

- 28.4.** Responsibility: To obtain true economy, the City must conduct Solicitations to minimize the possibility of a subsequent default by the contractor, late deliveries, or other unsatisfactory performance that may result in additional administrative costs. It is important that the Offeror be a responsible contractor. Responsibility includes the Offeror's integrity, skill, capacity, experience, and facilities for conducting the work to be performed.
- 28.5.** The Procurement Officer will review each Offer to determine if the Offeror is responsible and responsive. The City's determination as to whether an Offeror is responsible will be based on all information furnished by the Offeror, interviews (if any), and information received from Offeror's references, including information about Offeror's history, terminations for convenience or cause, contract breach lawsuits or notices of claim and any other sources the City deems appropriate. Award of the Contract resulting from the Solicitation will not be made until any necessary investigation, which each Offeror agrees to permit by submitting its Offer, is made by the City as it deems necessary. A review of responsibility may occur up to Contract award.
- 28.6.** Offeror's unreasonable failure to promptly supply information about an inquiry with respect to responsibility may be grounds for a determination of non-responsibility with respect to such Offeror.

Remainder of page intentionally left blank.



SECTION II- STANDARD TERMS AND CONDITIONS

CITY OF PHOENIX
Aviation Department
Contracts & Services Division
2485 E. Buckeye Road
Phoenix, AZ 85034

SECTION II – STANDARD TERMS AND CONDITIONS

1. DEFINITION OF KEY WORDS USED IN THE SOLICITATION:

Shall, Will, Must: Indicates a mandatory requirement. Failure to meet these mandatory requirements may result in the rejection of Offer as non-responsive.

Should: Indicates something that is recommended but not mandatory. If the Contractor fails to provide recommended information, the City may, at its sole option, ask the Contractor to provide the information or evaluate the offer without the information.

May: Indicates something that is not mandatory but permissible.

For purposes of this Solicitation, the following definitions will apply:

“A.R.S.” Arizona Revised Statute

“Buyer” or “Procurement Officer” City of Phoenix staff person responsible for the Solicitation. The City employee or employees who have specifically been designated to act as a contact person or persons to the Contractor, and responsible for monitoring and overseeing the Contractor's performance under this contract.

"City" The City of Phoenix

"Contractor" The individual, partnership, or corporation who, as a result of the competitive process, is awarded a contract by the City of Phoenix.

"Contract" or "Agreement" The legal agreement executed between the City of Phoenix, AZ, and the Contractor.

“Days” or “days” Means calendar days unless otherwise specified.

“Deputy Director” Aviation The contracting authority for the City of Phoenix, AZ, authorized to sign contracts and amendments thereto on behalf of the City of Phoenix, AZ.



SECTION II- STANDARD TERMS AND CONDITIONS

CITY OF PHOENIX
Aviation Department
Contracts & Services Division
2485 E. Buckeye Road
Phoenix, AZ 85034

“Employer”	Any individual or type of organization that transacts business in this state, that has a license issued by an agency in this state and employs one or more employees in this state. Employer includes this state, any political subdivision of this state and self-employed persons. In the case of an independent contractor, employer means the independent contractor and does not mean the person or organization that uses contract labor. (A.R.S. § 23-211).
Good Cause	Substantial grounds or evidence based upon facts not in dispute as determined by the Procurement Officer that the failure by an aggrieved party, an Offeror or a respondent to submit a timely offer, response, protest or appeal was beyond its control due to misinformation relayed in writing by a City employee.
“Offer”	Means a response from a supplier, contractor, or service provider to a Solicitation request that, if awarded, binds the supplier, contractor, or service provider to perform in accordance with the contract. Same as bid, proposal, quotation or tender.
“Offeror”	Any Vendor, Seller or Supplier submitting a competitive offer in response to a Solicitation from the City. Same as Bidder or Proposer.
“Solicitation”	Means an Invitation for Bid (IFB), Request for Proposal (RFP), Request for Quotations (RFQ), Request for Qualifications (RFQu) and request for sealed bids, or any other type of formal procurement which the City makes public through advertising, mailings, or some other method of communication. It is the process by which the City seeks information, proposals, bids, or quotes from suppliers.
“Suppliers”	Firms, entities, or individuals furnishing goods or services to the City.
“Vendor or Seller”	A seller of goods or services.



SECTION II- STANDARD TERMS AND CONDITIONS

CITY OF PHOENIX
Aviation Department
Contracts & Services Division
2485 E. Buckeye Road
Phoenix, AZ 85034

2. CONTRACT INTERPRETATION:

- 2.1. APPLICABLE LAW:** This Contract will be governed by the law of the State of Arizona, and suits pertaining to this Contract will be brought only in a federal or state court in Maricopa County, Arizona.
- 2.2. CONTRACT ORDER OF PRECEDENCE:** In the event of a conflict in the provisions of the Contract, as accepted by the City and as they may be amended, the following will prevail in the order set forth below:
- 2.2.1.** Special terms and conditions
 - 2.2.2.** Standard terms and conditions
 - 2.2.3.** Amendments
 - 2.2.4.** Statement or scope of work
 - 2.2.5.** Specifications
 - 2.2.6.** Attachments
 - 2.2.7.** Submittals
 - 2.2.8.** Exhibits
 - 2.2.9.** Instructions to Contractors
 - 2.2.10.** Other documents referenced or included in the Solicitation
- 2.3. ORGANIZATION – EMPLOYMENT DISCLAIMER:** The Contract resulting hereunder is not intended to constitute, create, give rise to or otherwise recognize a joint venture agreement or relationship, partnership or formal business organization of any kind, and the rights and obligations of the parties will be only those expressly set forth in the Contract. The parties agree that no persons supplied by the Contractor in the performance of Contractor's obligations under the Contract are considered to be City's employees and that no rights of City civil service, retirement or personnel rules accrue to such persons. Contractor will have total responsibility for all salaries, wage bonuses, retirement, withholdings, workmen's compensation, occupational disease compensation, unemployment compensation, other employee benefits and all taxes and premiums appurtenant thereto concerning such persons and will save and hold the City harmless with respect thereto.
- 2.4. SEVERABILITY:** The provisions of this Contract are severable to the extent that any provision or application held to be invalid will not affect any other provision or application of the Contract which may remain in effect without the invalid provision or application.



SECTION II- STANDARD TERMS AND CONDITIONS

CITY OF PHOENIX
Aviation Department
Contracts & Services Division
2485 E. Buckeye Road
Phoenix, AZ 85034

2.5. NON-WAIVER OF LIABILITY: The City, as a public entity supported by tax monies and in execution of its public trust, cannot agree to waive any lawful or legitimate right to recover monies lawfully due it. Therefore, Contractor agrees that it will not insist upon or demand any statement whereby the City agrees to limit in advance or waive any right the City might have to recover actual lawful damages in any court of law under applicable Arizona law.

2.6. PAROL EVIDENCE: This Contract is intended by the parties as a final expression of their agreement and is intended also as a complete and exclusive statement of the terms of this Contract. No course of prior dealings between the parties and no usage in the trade will be relevant to supplement or explain any term used in this Contract. Acceptance or acquiescence in a course of performance rendered under this Contract will not be relevant to determine the meaning of this Contract even though the accepting or acquiescing party has knowledge of the nature of the performance and opportunity to object.

3. CONTRACT ADMINISTRATION AND OPERATION:

3.1. RECORDS: All books, accounts, reports, files, and other records relating to this Contract will be subject at all reasonable times to inspection and audit by the City for five years after completion of the Contract. Such records will be produced at a City of Phoenix office as designated by the City. Confidentiality will be maintained, and City will not violate any proprietary or other confidentiality agreements Contractor has in place.

3.2. DISCRIMINATION PROHIBITED: Contractor agrees to abide by the provisions of the Phoenix City Code Chapter 18, Article V as amended.



SECTION II- STANDARD TERMS AND CONDITIONS

CITY OF PHOENIX
Aviation Department
Contracts & Services Division
2485 E. Buckeye Road
Phoenix, AZ 85034

Any contractor, in performing under this contract, will not discriminate against any worker, employee or applicant, or any member of the public, because of race, color, religion, sex, national origin, age or disability nor otherwise commit an unfair employment practice. The supplier and/or lessee will take action to ensure that applicants are employed, and employees are dealt with during employment without regard to their race, color, religion, sex, or national origin, age or disability and adhere to a policy to pay equal compensation to men and women who perform jobs that require substantially equal skill, effort and responsibility, and that are performed within the same establishment under similar working conditions. Such action will include but not be limited to the following: Employment, promotion, demotion or transfer, recruitment or recruitment advertising, layoff, or termination; rates of pay or other forms of compensation; and selection for training; including apprenticeship. The supplier further agrees that this clause will be incorporated in all subcontracts with all labor organizations furnishing skilled, unskilled, and union labor, or who may perform any such labor or services in connection with this contract. Contractor further agrees that this clause will be incorporated in all subcontracts, job-contractor agreements or subleases of this agreement entered into by supplier/lessee.

3.3. EQUAL EMPLOYMENT OPPORTUNITY AND PAY: In order to do business with the City, Contractor must comply with Phoenix City Code, 1969, Chapter 18, Article V, as amended, Equal Employment Opportunity Requirements. Contractor will direct any questions in regard to these requirements to the Equal Opportunity Department, (602) 262-6790.

3.3.1. For a Contractor with 35 employees or fewer: Contractor in performing under this Agreement shall not discriminate against any worker, employee or applicant, or any member of the public, because of race, color, religion, sex, national origin, age, or disability, nor otherwise commit an unfair employment practice. The Contractor will ensure that applicants are employed, and employees are dealt with during employment without regard to their race, color, religion, sex, national origin, age, or disability. Such action shall include but not be limited to the following: employment, promotion, demotion or transfer, recruitment or recruitment advertising, layoff, or termination; rates of pay or other forms of compensation; and selection for training; including apprenticeship. The Contractor further agrees that this clause will be incorporated in all subcontracts related to this Agreement that involve furnishing skilled, unskilled, and union labor, or who may perform any such labor or services in connection with this Agreement. Contractor further agrees that this clause will be incorporated in all subcontracts, Contractor agreements or subleases of this agreement entered by supplier/lessee.



SECTION II- STANDARD TERMS AND CONDITIONS

CITY OF PHOENIX
Aviation Department
Contracts & Services Division
2485 E. Buckeye Road
Phoenix, AZ 85034

3.3.2. For a Contractor with more than 35 employees: Contractor in performing under this Agreement shall not discriminate against any worker, employee or applicant, or any member of the public, because of race, color, religion, sex, national origin, age, or disability, nor otherwise commit an unfair employment practice. The Contractor will ensure that applicants are employed, and employees are dealt with during employment without regard to their race, color, religion, sex, national origin, age, or disability, and shall adhere to a policy to pay equal compensation to men and women who perform jobs that require substantially equal skill, effort, and responsibility, and that are performed within the same establishment under similar working conditions. Such action shall include but not be limited to the following: employment, promotion, demotion or transfer, recruitment or recruitment advertising, layoff, or termination; rates of pay or other forms of compensation; and selection for training; including apprenticeship. The Contractor further agrees that this clause will be incorporated in all subcontracts with all labor organizations furnishing skilled, unskilled, and union labor, or who may perform any such labor or services in connection with this contract. Contractor further agrees that this clause will be incorporated in all subcontracts, job-Contractor agreements, or subleases of this Agreement entered by supplier/lessee.

The Contractor further agrees not to discriminate against any worker, employee or applicant, or any member of the public, because of sexual orientation or gender identity or expression and shall ensure that applicants are employed, and employees are dealt with during employment without regard to their sexual orientation or gender identity or expression.

3.3.3. Documentation: Suppliers and lessees may be required to provide additional documentation to the Equal Opportunity Department affirming that a nondiscriminatory policy is being utilized.

3.3.4. Monitoring: The Equal Opportunity Department shall monitor the employment policies and practices of suppliers and lessees subject to this article as deemed necessary. The Equal Opportunity Department is authorized to conduct on-site compliance reviews of selected firms, which may include an audit of personnel and payroll records, if necessary.

3.4. LEGAL WORKER REQUIREMENTS: The City is prohibited by A.R.S. § 41-4401 from awarding a contract to any Contractor who fails, or whose subcontractors fail, to comply with A.R.S. § 23-214(A). Therefore, Contractor agrees that:



SECTION II- STANDARD TERMS AND CONDITIONS

CITY OF PHOENIX
Aviation Department
Contracts & Services Division
2485 E. Buckeye Road
Phoenix, AZ 85034

- 3.4.1.** Contractor and each subcontractor it uses warrants their compliance with all federal immigration laws and regulations that relate to their employees and their compliance with A.R.S. § 23-214, subsection A.
- 3.4.2.** A breach of a warranty under paragraph 1 will be deemed a material breach of the contract that is subject to penalties up to and including termination of the contract.
- 3.4.3.** The City retains the legal right to inspect the papers of any Contractor or subcontractor employee who works on this Contract to ensure that the Contractor or subcontractor is complying with the warranty under paragraph 1.
- 3.5. HEALTH, ENVIRONMENTAL AND SAFETY REQUIREMENTS:** Contractor's products, services and facilities will be in full compliance with all applicable federal, state and local health, environmental and safety laws, regulations, standards, codes and ordinances, regardless of whether or not they are referred to by the City.
- At the request of City representatives, Contractor will provide the City:
- 3.5.1.** Environmental, safety and health regulatory compliance documents (written safety programs, training records, permits, etc.) applicable to services provided by the Contractor in this Contract.
- 3.5.2.** A list of all federal, state, or local (EPA, OSHA, Maricopa County, etc.) citations or notice of violations issued against their firm or their subcontractors including dates, reasons, dispositions, and resolutions.
- 3.5.3.** The City will have the right, but not the obligation to inspect the facilities, transportation vehicles or vessels, containers and disposal facilities provided by the Contractor or subcontractor. The City will also have the right to inspect operations conducted by the Contractor or subcontractor in the performance of this agreement. The City further reserves the right to make unannounced inspections of the Contractor's facilities (during normal business hours).
- 3.6. COMPLIANCE WITH LAWS:** Contractor agrees to fully observe and comply with all applicable federal, state, and local laws, regulations, standards, codes and ordinances when performing under this Contract regardless of whether they are being referred to by the City. Contractor agrees to permit City inspection of Contractor's business records, including personnel records to verify any such compliance.



SECTION II- STANDARD TERMS AND CONDITIONS

CITY OF PHOENIX
Aviation Department
Contracts & Services Division
2485 E. Buckeye Road
Phoenix, AZ 85034

Because Contractor will be acting as an independent contractor, the City assumes no responsibility for the Contractor's acts. Contractor will comply with the provisions of the Supplemental Terms and Conditions to All Airport Agreements, attached as Exhibit A and incorporated by reference.

- 3.7. LAWFUL PRESENCE REQUIREMENT:** Pursuant to A.R.S. §§ 1-501 and -502, the City is prohibited from awarding a contract to any natural person who cannot establish that he or she is lawfully present in the United States. In order to establish lawful presence, this person must produce qualifying identification and sign a City-provided affidavit affirming that the identification provided is genuine. This requirement will be imposed at the time of Contract award. In the event the prevailing responder is unable to satisfy this requirement, the City will offer the award to the next-highest scoring responder. The law does not apply to fictitious entities such as corporations, partnerships and limited liability companies
- 3.8. CONTINUATION DURING DISPUTES:** Contractor agrees that notwithstanding the existence of any dispute between the parties, insofar as is possible, under the terms of the Contract, Contractor will continue to perform the obligations required of Contractor during the continuation of any such dispute unless enjoined or prohibited by an Arizona court of competent jurisdiction.
- 3.9. EMERGENCY PURCHASES:** The City reserves the right to purchase from other sources those items which are required on an emergency basis and cannot be supplied immediately from stock by the Contractor.

4. COSTS AND PAYMENTS:

- 4.1. GENERAL:** Any prompt payment terms offered must be clearly noted by the Contractor on all invoices submitted to the City for the payment of goods or services received. The City will make every effort to process payment for the purchase of material or services within thirty to forty-five calendar days after receipt of a correct invoice, unless a good faith dispute exists to any obligation to pay all or a portion of the account. Payment terms are specified in the Offer.
- 4.2. PAYMENT DEDUCTION OFFSET PROVISION:** Contractor acknowledges that the City Charter requires that no payment be made to any Contractor as long as there is an outstanding obligation due to the City. Contractor agrees that any obligation it owes to the City will be offset against any payment due to the Contractor from the City.
- 4.3. LATE SUBMISSION OF CLAIM BY CONTRACTOR:** The City will not honor any invoices or claims which are tendered one year after the last item of the account accrued.



SECTION II- STANDARD TERMS AND CONDITIONS

CITY OF PHOENIX
Aviation Department
Contracts & Services Division
2485 E. Buckeye Road
Phoenix, AZ 85034

- 4.4. **DISCOUNTS:** Payment discounts will be computed from the date of receiving acceptable products, materials and/or services or correct invoice, whichever is later to the date payment is mailed.
- 4.5. **NO ADVANCE PAYMENTS:** Advance payments are not authorized. Payment will be made only for actual services or commodities that have been received, unless addressed specifically in the Scope of Work for subscription services.
- 4.6. **FUND APPROPRIATION CONTINGENCY:** Contractor recognizes that any agreement entered into will commence upon the day first provided and continue in full force and effect until termination in accordance with its provisions. Contractor and the City herein recognize that the continuation of the Contract after the close of any given fiscal year of the City, which ends on June 30th of each year, will be subject to the approval of the budget of the City providing for or covering such Contract item as an expenditure therein. The City does not represent that said budget item will be actually adopted, said determination being the determination of the City Council at the time of the adoption of the budget.
- 4.7. **MAXIMUM PRICES:** The City will not be invoiced at prices higher than those stated in the Contract resulting from this Offer. Contractor certifies, by signing this Offer, that the prices offered are no higher than the lowest price Contractor charges other buyers for similar quantities under similar conditions, as applicable and shown by quotes for like services and goods. Contractor further agrees that any reductions in the price of the goods or services covered by this Contract and occurring after award will apply to the undelivered balance. Contractor will promptly notify the City of such price reductions.
- 4.8. **F.O.B. POINT:** All prices are to be quoted F.O.B. delivered, unless specified elsewhere in this Solicitation.

5. CONTRACT CHANGES:

- 5.1. **CONTRACT AMENDMENTS:** This Contract will be modified only by a written contract amendment signed persons duly authorized to enter into contracts on behalf of Contractor. No verbal agreement or conversation with any officer, agent, or employee of the City, either before or after execution of the Contract, will affect or modify any of the terms or obligations contained or to be contained in the Contract. Any such verbal agreements or conversation shall be considered as unofficial information and in no way binding upon the City or Contractor. All agreements shall be in writing and Contract changes shall be by written amendment signed by both parties.



SECTION II- STANDARD TERMS AND CONDITIONS

CITY OF PHOENIX
Aviation Department
Contracts & Services Division
2485 E. Buckeye Road
Phoenix, AZ 85034

5.2. ASSIGNMENT - DELEGATION: No right or interest in this Contract nor monies due hereunder will be assigned in whole or in part without written permission of the City. No delegation of any duty of Contractor may be made without prior written permission of the City. Any assignment or delegation made in violation of this section will be void.

5.3. NON-EXCLUSIVE CONTRACT: The Contract resulting from this Solicitation will be awarded with the understanding and agreement that it is for the sole convenience of the City. The City reserves the right to obtain like goods or services from another source when necessary.

6. RISK OF LOSS AND LIABILITY:

6.1. TITLE AND RISK OF LOSS: The title and risk of loss of material or service will not pass to the City until the City actually receives the material or service at the point of delivery; and such loss, injury, or destruction will not release seller from any obligation hereunder.

6.2. ACCEPTANCE: All material or service is subject to final inspection and acceptance by the City. Material or service failing to conform to the specifications of this Contract will be held at Contractor's risk and may be returned to the Contractor. If so returned, all costs are the responsibility of the Contractor. Noncompliance will conform to the cancellation clause set forth in this document.

6.3. FORCE MAJEURE: Except for payment of sums due, neither party will be liable to the other nor deemed in default under this Contract if and to the extent that such party's performance of this Contract is prevented by reason of force majeure. The term "force majeure" means an occurrence that is beyond the control of the party affected and occurs without its fault or negligence. Force majeure will not include late performance by a subcontractor unless the delay arises out of a force majeure occurrence in accordance with this force majeure term and condition.

If either party is delayed at any time in the progress of the work by force majeure, the delayed party will notify the other party in writing of such delay, as soon as is practical, of the commencement thereof and will specify the causes of such delay in such notice. Such notice will be hand-delivered or mailed certified-return receipt and will make a specific reference to this provision, thereby invoking its provisions. The delayed party will cause such delay to cease as soon as practicable and will notify the other party in writing when it has done so. The time of completion will be extended by Contract modification for a period of time equal to the time that results, or effects of such delay prevent the delayed party from performing in accordance with this Contract.



SECTION II- STANDARD TERMS AND CONDITIONS

CITY OF PHOENIX
Aviation Department
Contracts & Services Division
2485 E. Buckeye Road
Phoenix, AZ 85034

6.4. LOSS OF MATERIALS: The City does not assume any responsibility, at any time, for the protection of or for loss of materials, from the time that the Contract operations have commenced until the final acceptance of the work by the project manager.

6.5. CONTRACT PERFORMANCE: Contractor will furnish all necessary labor, tools, equipment, and supplies to perform the required services at the City facilities designated, unless otherwise specifically addressed in the scope, or elsewhere in this Contract. The City's authorized representative will decide all questions which may arise as to the quality and acceptability of any work performed under the Contract. If, in the opinion of the City's authorized representative, performance becomes unsatisfactory, the City will notify the Contractor.

Contractor will have 30 days from that time to correct any specific instances of unsatisfactory performance, unless a different amount of time is specified in the agreement. In the event the unsatisfactory performance is not corrected within the time specified, the City will have the immediate right to complete the work to its satisfaction and will deduct the cost to cover from any balances due or to become due the Contractor. Repeated incidences of unsatisfactory performance may result in cancellation of the Contract for default.

6.6. DAMAGE TO CITY PROPERTY: Contractor will perform all work so that no damage to the building or grounds results. Contractor will repair any damage caused to the satisfaction of the City at no cost to the City.

Contractor will take care to avoid damage to adjacent finished materials that are to remain. If finished materials are damaged, Contractor will repair and finish to match existing material as approved by the City at Contractor's expense.

7. CITY'S CONTRACTUAL RIGHTS:

7.1. RIGHT OF ASSURANCE: Whenever one party to this Contract has reason to question the other party's intent to perform, the former party may demand that the other party give a written assurance of this intent to perform. In the event that a demand is made, and no written assurance is given within five days, the demanding party may treat this failure as an anticipatory repudiation of this Contract.

7.2. NON-EXCLUSIVE REMEDIES: The rights and remedies of the City under this Contract are non-exclusive.



SECTION II- STANDARD TERMS AND CONDITIONS

CITY OF PHOENIX
Aviation Department
Contracts & Services Division
2485 E. Buckeye Road
Phoenix, AZ 85034

- 7.3. DEFAULT IN ONE INSTALLMENT TO CONSTITUTE BREACH:** Each installment or lot of the Contract is dependent on every other installment or lot and a delivery of non-conforming goods or a default of any nature under one installment or lot will impair the value of the whole Contract and constitutes a total breach of the Contract as a whole.
- 7.4. ON TIME DELIVERY:** Because the City is providing services which involve health, safety and welfare of the general public, delivery time is of the essence. Delivery must be made in accordance with the delivery schedule promised by the Contractor.
- 7.5. DEFAULT:** In case of default by the Contractor, the City may, by written notice, cancel this Contract and repurchase from another source and may recover the excess costs by (1) deduction from an unpaid balance due; (2) collection against the bid and/or performance bond, or (3) a combination of the aforementioned remedies or other remedies as provided by law.
- 7.6. COVENANT AGAINST CONTINGENT FEES:** Contractor warrants that no person or selling agent has been employed or retained to solicit or secure this Contract upon an agreement or understanding for a commission, percentage, brokerage, or contingent fee, excepting bona fide employers or bona fide established commercial or selling agencies maintained by the seller for the purpose of securing business. For breach or violation of this warranty, the City will have the right to annul the Contract without liability or in its discretion to deduct from the Contract price a consideration, or otherwise recover the full amount of such commission, brokerage or contingent fee.
- 7.7. COST JUSTIFICATION:** In the event only one Offer is received, the City may require that the Offeror submit a cost proposal in sufficient detail for the City to perform a cost/price analysis to determine if the Offer price is fair and reasonable.
- 7.8. WORK PRODUCT, EQUIPMENT AND MATERIALS:** All work product, equipment, or materials created or purchased under this Contract belongs to the City and must be delivered to the City at City's request upon termination of this contract. Contractor agrees to assign to City all rights and interests Contractor may have in materials prepared under this Contract that are "works for hire" within the meaning of the copyright laws of the United States, including any right to derivative use of the material.



SECTION II- STANDARD TERMS AND CONDITIONS

CITY OF PHOENIX
Aviation Department
Contracts & Services Division
2485 E. Buckeye Road
Phoenix, AZ 85034

8. CONTRACT TERMINATION:

8.1. GRATUITIES: The City may, by written notice to the Contractor, cancel this Contract if it is found that gratuities, in the form of entertainment, gifts or otherwise, were offered or given by the Contractor or any agent or representative of the Contractor, to any officer or employee of the City making any determinations with respect to the performing of this Contract. In the event this Contract is canceled by the City pursuant to this provision, the City will be entitled, in addition to any other rights and remedies, to recover or withhold from the Contractor the amount of the gratuity.

8.2. CONDITIONS AND CAUSES FOR TERMINATION:

8.2.1. This Contract may be terminated at any time by mutual written consent, or by the City, with or without cause, upon giving thirty-day written notice to Contractor. The City at its convenience, by written notice, may terminate this Contract, in whole or in part. If this Contract is terminated, the City will be liable only for payment under the payment provisions of this Contract for services rendered and accepted material received by the City before the effective date of termination. Title to all materials, work-in-process and completed but undeliverable goods, will pass to the City after costs are claimed and allowed. Contractor will submit detailed cost claims in an acceptable manner and will permit the City to examine such books and records as may be necessary in order to verify the reasonableness of any claims.

8.2.2. The City reserves the right to cancel the whole or any part of this Contract due to failure of Contractor to carry out any term, promise, or condition of the contract. The City will issue a written notice of default to Contractor for acting or failing to act as in any of the following:

- In the opinion of the City, Contractor provides personnel who do not meet the requirements of the Contract;
- In the opinion of the City, Contractor fails to perform adequately the stipulations, conditions or services/specifications required in this Contract;
- In the opinion of the City, Contractor attempts to impose on the City personnel or materials, products or workmanship, which is of an unacceptable quality.
- Contractor fails to furnish the required service and/or product within the time stipulated in the Contract.



SECTION II- STANDARD TERMS AND CONDITIONS

CITY OF PHOENIX
Aviation Department
Contracts & Services Division
2485 E. Buckeye Road
Phoenix, AZ 85034

- In the opinion of the City, Contractor fails to make progress in the performance of the requirements of the Contract and/or give the City a positive indication that Contractor will not or cannot perform to the requirements of the Contract.

8.3. CONTRACT CANCELLATION: All parties acknowledge that this Contract is subject to cancellation by the City of Phoenix pursuant to the provision of A.R.S. § 38-511.

9. STATE AND LOCAL TRANSACTION PRIVILEGE TAXES:

In accordance with applicable state and local law, transaction privilege taxes may be applicable to this transaction. The state and local transaction privilege (sales) tax burden and legal liability to remit taxes are on the vendor that is conducting business in Arizona and the City of Phoenix. Any failure by Contractor to collect applicable taxes from the City will not relieve the Contractor from its obligation to remit taxes. It is the responsibility of the Offeror to determine any applicable taxes. The City will look at the price or Offer submitted and will not deduct, add, or alter pricing based on speculation or application of any taxes, nor will the City provide advice or guidance. If you have questions regarding your tax liability, please seek advice from a tax professional prior to submitting your Offer. You may also find information at <https://www.phoenix.gov/finance/plt> or <https://www.azdor.gov/Business.aspx>. Once your Offer is submitted, the Offer is valid for the time specified in this Solicitation, regardless of mistake or omission of tax liability. If the City finds over payment of a project due to tax consideration that was not due, the Contractor will be liable to the City for that amount, and by contracting with the City, the Contractor agrees to remit any overpayments back to the City for miscalculations on taxes included in an offer price.

10. TAX INDEMNIFICATION:

Contractor will pay all federal, state, and local taxes applicable to its operation and any persons employed by the Contractor and require the same of all subcontractors. Contractor will hold the City harmless from any responsibility for taxes, damages and interest, if applicable, contributions required under federal, and/or state and local laws and regulations and any other costs including transaction privilege taxes, unemployment compensation insurance, Social Security and Worker's Compensation, and require the same of all subcontractors.



SECTION II- STANDARD TERMS AND CONDITIONS

CITY OF PHOENIX
Aviation Department
Contracts & Services Division
2485 E. Buckeye Road
Phoenix, AZ 85034

11. TAX RESPONSIBILITY QUALIFICATION:

Contractor may be required to establish, to the satisfaction of City, that any and all fees and taxes due to the City or the State of Arizona for any License or Transaction Privilege taxes, Use Taxes, or similar excise taxes are currently paid (except for matters under legal protest). Contractor agrees to a waiver of the confidentiality provisions contained in the City Finance Code and any similar confidentiality provisions contained in Arizona statutes relative to State Transaction Privilege Taxes or Use Taxes. Contractor agrees to provide written authorization to the City Finance Department and to the Arizona State Department of Revenue to release tax information relative to Arizona Transaction Privilege Taxes or Arizona Use Taxes in order to assist the Department in evaluating Contractor's qualifications for and compliance with the Contract for duration of the term of the Contract.

12. NO ISRAEL BOYCOTT:

If this Contract is valued at \$100,000 or more and requires Contractor (a company engaging in for-profit activity and having ten or more full-time employees) to acquire or dispose of services, supplies, information technology, or construction, then Contractor must certify and agree that it does not and will not boycott goods or services from Israel, pursuant to Title 35, Chapter 2, Article 9 of the Arizona Revised Statutes. Provided that these statutory requirements are applicable, Contractor by entering this Contract now certifies that it is not currently engaged in, and agrees for the duration of the Contract to not engage in, a boycott of goods or services from Israel.

13. ATTORNEY FEES:

In any contested action related to or arising out of this Contract, the prevailing party shall recover its attorney fees, court costs, and other expenses from the other party. Where there are no competing claims, "prevailing party" means the party that substantially obtained the relief sought. Where there are competing claims, the prevailing party is the net winner or the party who prevailed in a totality of the litigation.

14. HEADINGS:

Headings for articles, sections, and paragraphs are for reference only and do not limit the content or scope of any provision of this Contract.

15. NATIONAL EMERGENCY:

This Contract is subject to the right of the United States to control, operate, and regulate the Airport and to use of the Airport during the time of war or national emergency.



SECTION II- STANDARD TERMS AND CONDITIONS

CITY OF PHOENIX
Aviation Department
Contracts & Services Division
2485 E. Buckeye Road
Phoenix, AZ 85034

16. NO IMPAIRMENT OF TITLE:

Contractor and its agents, employees, and contractors shall not cause or allow any person or entity to cause any lien, cloud, charge, or encumbrance to be filed, recorded, or imposed on the Airports or any portion thereof.

17. NO PERSONAL LIABILITY:

The City's officers, officials, agents, and employees are not personally liable to the Contractor for any default or breach of this Contract by the City, are not liable for any amount that may become due to the Contractor and are not obligated to perform under any provision of this Contract.

18. SUCCESSORS AND ASSIGNS:

This Contract binds the parties and their owners, officers, directors, managers, members, agents, employees, representatives, trustees, executors, personal representatives, and successors.

19. TERMINATION FOR NON-APPROPRIATION OF FUNDS:

This Contract is contingent on the appropriation of adequate funds by the Phoenix City Council for each fiscal year during the term of this Contract. If adequate funds are not appropriated, then this Contract shall terminate on June 30 of the last fiscal year for which funds were appropriated. The termination shall be without penalty or any liability by the City.

20. BREACH AND REMEDIES FOR BREACH:

The occurrence of any of the following events shall be deemed a material breach of this Contract by Contractor:

- Contractor fails to pay any amount when due and the failure continues for ten (10) days after notice from the City.
- Except for the non-monetary events of breach listed below, Contractor fails to perform any non-monetary obligation under this Contract and the failure continues for ten (10) days after notice from the City.
- Contractor fails to procure and maintain the insurance coverages required under this Contract and the failure continues for one (1) day after notice from the City.
- Contractor breaches any other lease, contract, agreement, or permit it has with the City.



SECTION II- STANDARD TERMS AND CONDITIONS

CITY OF PHOENIX
Aviation Department
Contracts & Services Division
2485 E. Buckeye Road
Phoenix, AZ 85034

- Contractor files a voluntary petition in bankruptcy; is adjudicated bankrupt or insolvent; takes the benefit of any law applicable to bankrupt or insolvent debtors; files a petition or is seeking reorganization, arrangement, composition, readjustment, liquidation, dissolution, or similar relief; seeks or acquiesces to the appointment of a trustee, receiver, or liquidator of all or a substantial part of Contractor's assets; or makes any general assignment for the benefit of creditors.
- Contractor violates any federal, state, or local law, rule, regulation, or ordinance related to this Contract and the violation continues for ten (10) days after notice from the City.

Upon the occurrence of any breach by Contractor, the City may elect to do any or all the following at one time or over a period of time:

- File a civil action or actions to, among other things, enforce this Contract and recover all amounts due, all attorney fees, court costs, and other expenses incurred.
- Exercise any and all remedies allowed at law or in equity.
- Recover all attorney fees, court costs, and other expenses incurred, whether or not a civil action or other judicial proceeding is filed.

The City's exercise of any remedy does not terminate and shall not be construed to terminate this Contract. Termination of this Contract must be evidenced by a writing signed by the City for that purpose. The foregoing list of remedies is not exhaustive, and the rights and remedies of the City under this Contract are non-exclusive.

21. CLAIMS AGAINST THE CITY:

Contractor shall comply with the procedures set forth in Chapter XVIII, § 14 of the Charter of the City of Phoenix (claims or demands against the City) and A.R.S. § 12-821 and § 12-821.01 (notice of claim statutes) for presenting claims or demands against the City. Nothing in this Contract constitutes a contractual term that requires a dispute resolution process, an administrative claims process, or review process, as those terms are used in A.R.S. § 12-821.01(C), so as to affect the date on which a cause of action accrues under A.R.S. § 12-821.01(A) and (B).

22. DELINQUENT ACCOUNT FEE:

Any amount that is not paid by Contractor when due is deemed delinquent. If the delinquent amount remains unpaid for ten (10) days, then a delinquent account fee of eighteen percent (18%) per annum shall be assessed according to Phoenix City Code § 4-7. Delinquent account fees shall be computed and accrued on a daily basis and assessed until the account balance, including delinquent account fees, is paid in full. Delinquent account fees are due from Contractor upon demand by the City.



SECTION II- STANDARD TERMS AND CONDITIONS

CITY OF PHOENIX
Aviation Department
Contracts & Services Division
2485 E. Buckeye Road
Phoenix, AZ 85034

23. ENTIRE AGREEMENT:

This Contract constitutes the entire agreement between the parties and supersedes all prior written and oral agreements, understandings, discussions, proposals, negotiations, communications, representations, and correspondence related to this Contract. The parties are not bound by any obligation not provided for in this Contract. Contractor certifies that it was not induced to enter into this Contract by any misrepresentation, undue influence, or coercion by the City or any of its officers, officials, agents, or employees. The Exhibits attached to this Contract are material parts of this Contract and are incorporated herein by this reference.

24. FAIR INTERPRETATION:

Contractor agrees that the rule that ambiguous or vague language in a contract is construed against the drafter is waived and does not apply to this Contract. Contractor agrees that this Contract shall be interpreted fairly and not against the City simply because the City drafted this Contract.

25. NO THIRD-PARTY BENEFICIARIES:

Except as expressly provided in this Contract, nothing contained herein creates or may be construed to create any right or privilege in any person or entity that is not a party to this Contract.

26. NOTICE:

All notices, consents, approvals, and other communications (notices) between the City and Contractor that are required to be given under this Contract shall be in writing and given by (A) personal delivery, (B) email with return receipt requested (read receipt), (C) facsimile transmittal with delivery confirmation, (D) prepaid delivery to any commercial air courier or express delivery service, or (E) registered or certified mail, postage prepaid and return receipt requested, through the United States Postal Service.

Notices to the City shall be sent to:

City of Phoenix
Aviation Department
ATTN: Alvin McDonnell
2515 E. Buckeye Road
Phoenix, Arizona 85034



SECTION II- STANDARD TERMS AND CONDITIONS

CITY OF PHOENIX
Aviation Department
Contracts & Services Division
2485 E. Buckeye Road
Phoenix, AZ 85034

With copies to:

City of Phoenix
Aviation Department, Contracts & Services Division
ATTN: Amy Turner
2485 East Buckeye Road
Phoenix, AZ 85034
Amy.m.turner@phoenix.gov

Notice given in compliance with this Section is deemed received (A) on the day it is personally delivered, (B) on the day it is sent by email, (C) on the day it is sent by facsimile transmittal, (D) two (2) days after it is deposited with any commercial air courier or express delivery service, or (E) five (5) days after it is sent by registered or certified mail as provided above. Any time period stated in a notice shall commence on the date the notice is deemed received. Actual receipt is not required.

If notice is sent by email or facsimile transmittal, then a paper copy shall be sent by prepaid regular first-class mail through the United States Postal Service to the Party at the address listed above. Duplicate notice is merely a courtesy and does not change or extend the effective date of the notice. The failure to receive the duplicate notice does not affect the validity of the notice sent by email or facsimile transmittal.

27. TITLE VI SOLICITATION NOTICE:

The City of Phoenix, in accordance with the provisions of Title VI of the Civil Rights Act of 1964 (78 Stat. 252, 42 USC §§ 2000d to 2000d-4) and the Regulations, hereby notifies Offerors that it will affirmatively ensure that any contract entered into pursuant to this advertisement, disadvantaged business enterprises will be afforded full and fair opportunity to submit proposals in response to this invitation and will not be discriminated against on the grounds of race, color, or national origin in consideration for an award.

Remainder of page intentionally left blank.



SECTION III – SPECIAL TERMS AND CONDITIONS

CITY OF PHOENIX
Aviation Department
Contracts & Services Division
2485 E. Buckeye Road
Phoenix, AZ 85034

SECTION III-SPECIAL TERMS AND CONDITIONS

1. TERM OF CONTRACT:

The term of the Contract derived from this RFQu will commence on or about February 1, 2023 and shall continue for five (5) years.

2. FREIGHT / DELIVERY:

Freight/delivery, including handing charges, will be reimbursed based on the actual cost with **no-mark-up**. Documentation of the shipping cost must be included with the final invoice for payment.

All deliveries shall be made between the hours of 6:00 a.m. and 4:00 p.m. Monday through Friday, excluding City holidays. To schedule and ensure that delivery can be accepted, please make a call to **602-273-3426** at least 24 hours prior to delivery. Contractor shall include pre-delivery and warranty checklists with the shipment, if applicable.

City of Phoenix
Aviation Department, Facilities & Services Division
2515 E. Buckeye Road
Phoenix, Arizona 85034

3. METHOD OF ORDERING (PURCHASE ORDERS):

Contractor shall deliver items and/or services only upon receipt of a written purchase order issued by the requesting Division. All Contractor invoices and packing/delivery tickets must include the City of Phoenix purchase order number.

4. METHOD OF INVOICING:

Invoice must be emailed in .pdf format to invoices@phoenix.gov and must include the following:

- City purchase order number or shopping cart number
- Items listed individually by the written description and part number.
- Unit price, extended and totaled.
- Quantity ordered, back ordered, and shipped.
- Applicable tax.
- Invoice number and date.
- Delivery address
- Payment terms.
- FOB terms.
- Remit to address



SECTION III – SPECIAL TERMS AND CONDITIONS

CITY OF PHOENIX
Aviation Department
Contracts & Services Division
2485 E. Buckeye Road
Phoenix, AZ 85034

5. METHOD OF PAYMENT:

Payment to be made from Contractor's invoice, and a copy of the signed delivery invoices submitted to cover items received and accepted during the billing period. Invoices must contain the Contract number or Offer number under which the contract is awarded.

6. DELIVERY/SERVICE TICKET:

Contractor shall provide a packing list or service ticket for items delivered to the City or services provided to the City. Tickets should include the following and a legible copy shall be provided to the City:

- Date
- City purchase order number
- Written description of services which were provided
- Itemized list of materials which were delivered, including quantity
- A unique identification number and Contractor name
- Signature of City employee who accepted for the materials/services

7. PARTIAL PAYMENTS:

Partial payments are not authorized on individual purchase orders. Payment will be made upon final delivery and acceptance of all goods and services on the purchase order.

8. SUPPLIER PROFILE CHANGES:

It is the responsibility of the Contractor to promptly update their profile in ProcurePHX at www.phoenix.gov/procure. If Contractor's legal identify has changed, the Procurement Officer must be notified immediately. Failure to do so may result in non-payment of invoices and Contract termination.

9. AUTHORIZED CHANGES:

The City reserves the right at any time to make changes in any one or more of the following: (a) specifications; (b) methods of shipment or packing; (c) place of delivery; (d) time of delivery; and/or (e) quantities. If the change causes an increase or decrease in the cost of or the time required for performance, an equitable adjustment may be made in the price or delivery schedule, or both. Any claim for adjustment will be deemed waived unless asserted in writing within thirty days from the receipt of the change. Price increases or extensions of delivery time will not be binding on the City unless evidenced in writing and approved by the Deputy Aviation Director prior to the institution of the change.



SECTION III – SPECIAL TERMS AND CONDITIONS

CITY OF PHOENIX
Aviation Department
Contracts & Services Division
2485 E. Buckeye Road
Phoenix, AZ 85034

10. SUSPENSIONS OF WORK:

The Procurement Officer and the project manager reserve the right to suspend work wholly or in part if deemed necessary for the best interest of the City. This suspension will be without compensation to the Contractor, other than to adjust the Contract completion/delivery requirements.

11. HOURS OF WORK:

All work under this Contract shall be coordinated with the City's project manager. Any changes to the established schedule must have prior written approval by the City's project manager.

12. POST AWARD CONFERENCE:

A post-award conference will be held by the Procurement Officer or project manager prior to commencement of any work on the project. The purpose of this conference is to discuss critical elements of the work schedule and operational problems and procedures.

13. PERFORMANCE INTERFERENCE:

Contractor shall notify the Aviation Department Representative (ADR) immediately of any occurrence and/or condition that interferes with the full performance of the Contract and confirm it in writing within 24 hours.

Aviation Department Contact: Alvin McDonnell
Email: Alvin.McDonnell@phoenix.gov
Phone: 602-683-3905

14. COOPERATIVE AGREEMENT:

In addition to the City and with approval of the Contractor, this Contract may be extended for use by other municipalities and government agencies in the State of Arizona.

A current listing of eligible entities may be found at www.mesaaz.gov/business/purchasing/save. Any such usage by other entities must be in accordance with the ordinance, charter and/or procurement rules and regulations of the respective entity. Orders placed by other agencies and payment thereof will be the sole responsibility of that entity. The City shall not be responsible for any disputes arising out of transactions made by other entities who utilize this Solicitation.

15. ADVERTISING:

Contractor will not advertise or publish news releases concerning this Contract without the prior written consent of the Deputy Aviation Director, and the City will not unreasonably withhold permission.



SECTION III – SPECIAL TERMS AND CONDITIONS

CITY OF PHOENIX
Aviation Department
Contracts & Services Division
2485 E. Buckeye Road
Phoenix, AZ 85034

16. EXCLUSIVE POSSESSION:

All services, information, computer program elements, reports, and other deliverables which may be created under this Contract are the sole property of the City of Phoenix and will not be used by the Contractor or any other person except with prior written permission by the City.

17. STRICT PERFORMANCE:

Failure of either party to insist upon the strict performance of any item or condition of the contract or to exercise or delay the exercise of any right or remedy provided in the contract, or by law, or the acceptance of materials or services, obligations imposed by this Contract or by law will not be deemed a waiver of any right of either party to insist upon the strict performance of the Contract.

18. LICENSES AND PERMITS:

Contractor will keep current federal, state, and local licenses and permits required for the operation of the business conducted by the Contractor as applicable to this Contract.

19. DELIVERY:

Delivery is an important consideration and will be a factor in determining the award of subsequent requests. A delivery time after receipt of order (ARO) must be stated in definite terms. Should there be variations in delivery times by item, the submittal should be clear concerning these variations.

20. MISCELLANEOUS FEES:

Additional charges for fuel surcharges, delivery charges, dealer prep, environmental fees, waste disposal, shop supplies, set-up, freight and/or shipping and handling, etc. will not be paid. These costs must be incorporated in the pricing provided in the bid price schedule.

21. DEMONSTRATION:

The City may, in its discretion, require a demonstration of the products or services offered as part of the evaluation process. The demonstration shall be provided by the Contractor at no cost to the City for the period deemed sufficient to properly evaluate the product or service. The exact time, conditions, and terms of the evaluation shall be established at the time a demonstration is requested.



SECTION III – SPECIAL TERMS AND CONDITIONS

CITY OF PHOENIX
Aviation Department
Contracts & Services Division
2485 E. Buckeye Road
Phoenix, AZ 85034

22. LIQUIDATED DAMAGES:

If the Contractor fails to deliver the supplies or perform the services within the time specified in its Contract, or any extension thereof, the actual damages to the City for the delay will be difficult or impossible to determine. Therefore, in lieu of actual damages, the Contractor shall pay to the City as fixed, agreed and liquidated damages for each calendar day of the delay for each order, the amount of **\$200**. The City may terminate this Contract in whole or in part as provided in the "Default" provision. In that event, the Contractor shall be liable for such liquidated damages accruing until the City may reasonably obtain delivery or performance of similar supplies and services. The Contractor shall not be charged with liquidated damages when the delay arises out of causes beyond its control and without fault or negligence, as determined by the City. The Deputy Aviation Director or Department Director will be the sole judge in determining the liquidated damages.

23. EVALUATION LITERATURE:

Offers submitted for products considered by the Contractor to be equal or better than the products specified herein must be submitted with technical literature and/or product brochures for the City's use to evaluate the offered products. Complete specifications, literature, illustrations, blueprints, photos etc. describing the offered product shall be included with the Offer. Contractor shall indicate any variation between the product offered and the literature submitted.

24. INDUSTRY STANDARDS:

It is intended that the manufacturer in the selection of components will use material and design practices that are the best available in the industry for the type of operating conditions to which the item will be subjected. Component parts shall be selected to give maximum performance, service life and safety and not merely meet the minimum requirements of this specification. All parts, equipment and accessories shall conform in strength, quality of material and workmanship to recognized industry standards. The City reserves the right to waive minor variations if, in the opinion of the ADR the basic unit meets the general intent of these specifications.

25. COMMUNICATION IN ENGLISH:

It is mandatory that the Contractor's lead person assigned to any City facility can speak, read, and write in English to effectively communicate with City staff.

26. PRE-DELIVERY INSPECTION:

Onsite inspection of the first unit may be required before delivery. The City reserves the right to inspect the first unit at the factory. This pre-delivery inspection does not constitute final acceptance of the product.



SECTION III – SPECIAL TERMS AND CONDITIONS

CITY OF PHOENIX
Aviation Department
Contracts & Services Division
2485 E. Buckeye Road
Phoenix, AZ 85034

27. INSPECTION AND ACCEPTANCE:

Each product delivered shall be subject to complete inspection by the City prior to acceptance. Inspection criteria shall include, but not be limited to, conformity to the specifications, mechanical integrity, quality, workmanship, and materials. Ten business days will be allowed for this process. If delivered items are unacceptable and returned to Contractor prior to acceptance, an additional five business days will be allowed for inspection when subsequent delivery occurs. It shall be Contractor's responsibility to pick up unacceptable products, correct the deficiencies, and return the product following the corrections.

28. SAMPLES:

Upon request, Contractor is required to furnish a sample of the goods to be supplied. Any sample submitted shall create an express warranty that the whole of the goods shall conform to the sample submitted. All samples become the property of the City unless designated otherwise by Contractor.

29. SUBSTITUTION OF SPECIFIED ITEMS:

Whenever in the specifications any item or process is requested or identified by manufacturer name, proprietary name, or patent such specifications shall be used to facilitate descriptions of the item or process and shall be followed by the words "or equal". Contractor may offer any item or process that is equal in every respect. However, if the item or process delivered is not, in the opinion of the City, equal in every respect to the specifications, then Contractor must furnish the item or material that is equal, in the opinion of the City.

30. NEW MATERIAL(S):

All materials offered shall be new supplied from the manufacturer.

31. CONFIDENTIALITY AND DATA SECURITY:

All data, regardless of form, including originals, images and reproductions, prepared by, obtained by, or transmitted to Contractor in connection with this Contract is confidential, proprietary information owned by the City, Contractor shall not disclose data generated in the performance of the service to any third person.

Contractor agrees to abide by all current applicable legal and industry data security and privacy requirements and subject to Payment Card Industry Standards, if applicable. A violation of this Section may result in immediate termination of this Agreement without notice. The obligations of Contractor under this Section shall survive the termination of this Contract.



SECTION IV-INSURANCE AND INDEMNIFICATION

CITY OF PHOENIX
Aviation Department
Contracts & Services Division
2485 E. Buckeye Road
Phoenix, AZ 85034

SECTION IV – INSURANCE AND INDEMNIFICATION

1. INDEMNIFICATION CLAUSE:

Contractor (“Indemnitor”) must defend, indemnify, and hold harmless the City of Phoenix and its officers, officials (elected or appointed), agents, and employees (“Indemnitee”) from and against any and all claims, actions, liabilities, damages, losses, or expenses (including but not limited to court costs, attorney fees, expert fees, and costs of claim processing, investigation and litigation) of any nature or kind whatsoever (“Losses”) caused, or alleged to be caused, in whole or in part, by the wrongful, negligent or willful acts, or errors or omissions of Indemnitor or any of its owners, officers, directors, members, managers, agents, employees or subcontractors (“Indemnitor’s Agents”) arising out of or in connection with this Agreement. This defense and indemnity obligation includes holding Indemnitee harmless for any Losses or other amount arising out of or recovered under any state’s Workers’ Compensation Law or arising out of the failure of Indemnitor or Indemnitor’s Agents to conform to any federal, state or local law, statute, ordinance, rule, regulation or court decree. Indemnitor’s duty to defend Indemnitee accrues immediately at the time a claim is threatened or a claim is made against Indemnitee, whichever is first. Indemnitor’s duty to defend exists regardless of whether Indemnitor is ultimately found liable. Indemnitor must indemnify Indemnitee from and against any and all Losses, except where it is proven that those Losses are solely as a result of Indemnitee’s own negligent or willful acts or omissions. Indemnitor will be responsible for primary loss investigation, defense, and judgment costs where this indemnification applies. In consideration of the award of this Agreement, Indemnitor agrees to waive all rights of subrogation against Indemnitee for losses arising from or related to any work performed by Indemnitor or Indemnitor’s Agents for the City of Phoenix. The obligations of Indemnitor under this provision survive the termination or expiration of this Agreement.

2. INSURANCE REQUIREMENTS:

- 2.1. Contractor and subcontractors must procure insurance against claims that may arise from or relate to performance of the work hereunder by Contractor and its agents, representatives, employees, and subcontractors. Contractor and subcontractors must maintain that insurance until all their obligations have been discharged, including any warranty periods under this Contract.
- 2.2. The City in no way warrants that the limits stated in this section are sufficient to protect Contractor from liabilities that might arise out of the performance of the work under this Contract by Contractor, its agents, representatives, employees or subcontractors and Contractor may purchase additional insurance as it determines necessary.



SECTION IV-INSURANCE AND INDEMNIFICATION

CITY OF PHOENIX
Aviation Department
Contracts & Services Division
2485 E. Buckeye Road
Phoenix, AZ 85034

2.3 SCOPE AND LIMITS OF INSURANCE: Contractor must provide coverage with limits of liability not less than those stated below. An excess liability policy or umbrella liability policy may be used to meet the liability limits provided that (1) the coverage is written on a “following form” basis, and (2) all terms under each line of coverage below are met.

Commercial General Liability – Occurrence Form

General Aggregate	\$2,000,000
Products – Completed Operations Aggregate	\$1,000,000
Personal and Advertising Injury	\$1,000,000
Each Occurrence	\$1,000,000

- The policy must name the City of Phoenix as an additional insured with respect to liability for bodily injury, property damage and personal and advertising injury with respect to premises, ongoing operations, products and completed operations and liability assumed under an insured contract arising out of the activities performed by, or on behalf of the Contractor related to this Contract.
- There shall be no endorsement or modification which limits the scope of coverage or the policy limits available to the City of Phoenix as an additional insured.
- City of Phoenix is an additional insured to the full limits of liability purchased by the Contractor.
- The Contractor’s insurance coverage must be primary and non-contributory with respect to any insurance or self-insurance carried by the City.

3. NOTICE OF CANCELLATION:

For each insurance policy required by the insurance provisions of this Contract, the Contractor must provide to the City, within 2 business days of receipt, a notice if a policy is suspended, voided, or cancelled for any reason. Such notice must be mailed, emailed, hand delivered or sent by facsimile transmission to:

City of Phoenix
Aviation Department
Contracts and Services Division
2485 E. Buckeye Road
Phoenix, AZ 85034-4301



SECTION IV-INSURANCE AND INDEMNIFICATION

CITY OF PHOENIX
Aviation Department
Contracts & Services Division
2485 E. Buckeye Road
Phoenix, AZ 85034

4. ACCEPTABILITY OF INSURERS:

Insurance is to be placed with insurers duly licensed or authorized to do business in the state of Arizona and with an “A.M. Best” rating of not less than B+ VI. The City in no way warrants that the above-required minimum insurer rating is sufficient to protect the Contractor from potential insurer insolvency.

5. VERIFICATION OF COVERAGE:

Contractor must furnish the City with certificates of insurance (ACORD form or equivalent approved by the City) as required by this Contract. The certificates for each insurance policy are to be signed by a person authorized by that insurer to bind coverage on its behalf.

All certificates and any required endorsements are to be received and approved by the City before work commences. Each insurance policy required by this Contract must be in effect at or prior to commencement of work under this Contract and remain in effect for the duration of the project. Failure to maintain the insurance policies as required by this Contract or to provide evidence of renewal is a material breach of contract.

All certificates required by this Contract must be sent directly to Amy Turner at **Amy.m.turner@phoenix.gov**. The City project/contract number and project description must be noted on the certificate of insurance. The City reserves the right to require complete, certified copies of all insurance policies required by this Contract at any time. **DO NOT SEND CERTIFICATES OF INSURANCE TO THE CITY’S RISK MANAGEMENT DIVISION.**

The **initial certificates** required by this Contract shall be sent directly to:

City of Phoenix
Aviation Department
Contracts and Services Division
2485 E. Buckeye Road
Phoenix, AZ 85034-4301

All subsequent and renewal certificates of insurance and endorsements shall be sent directly to:

City of Phoenix
Aviation Department
c/o EXIGIS Insurance Compliance Services
P.O. Box 4668 – ECM #35050
New York, NY 10163-4668
Email: certificates-cityofphoenix@riskworks.com



SECTION IV-INSURANCE AND INDEMNIFICATION

CITY OF PHOENIX
Aviation Department
Contracts & Services Division
2485 E. Buckeye Road
Phoenix, AZ 85034

6. SUBCONTRACTORS:

Contractor's certificates shall include all subcontractors as additional insureds under its policies OR Contractor shall be responsible for ensuring and verifying that all subcontractors have valid and collectable insurance. At any time throughout the life of the contract, the City of Phoenix reserves the right to require proof from the Contractor that its subcontractors have insurance coverage. All subcontractors providing services included under this Contract's Scope of Services are subject to the insurance coverages identified above and must include the City of Phoenix as an additional insured. In certain circumstances, the Contractor may, on behalf of its subcontractors, waive a specific type of coverage or limit of liability where appropriate to the type of work being performed under the subcontract. Contractor assumes liability for all subcontractors with respect to this Contract.

7. APPROVAL:

Any modification or variation from the insurance requirements in this Contract must be made by the Law Department, whose decision is final. Such action will not require a formal Contract amendment but may be made by administrative action.

Remainder of page intentionally left blank.



SECTION V- SCOPE

CITY OF PHOENIX
Aviation Department
Contracts & Services Division
2485 E. Buckeye Road
Phoenix, AZ 85034

SECTION V – SCOPE

1. INTRODUCTION:

The City of Phoenix Aviation Department invites sealed Statements of Qualifications from qualified vendors to supply Common Use Passenger Processing System (CUPPS) and Common Use Self-Serve (CUSS) (common use paper) for boarding pass paper, standard bag tags, thermal paper rolls, and RFID bag tags for check-in counters, kiosks, and gates for airlines at Phoenix Sky Harbor International Airport (Airport) on an as-needed basis.

The Aviation Department will establish a Qualified Vendor List (QVL) of Vendors that are deemed qualified to provide airline common use paper as described in this Solicitation. The Aviation Department will evaluate the Offerors on a pass or fail basis for each listed product qualification criteria. Only those Offerors that receive a pass for the proposed product may be recommended for a Contract. Offerors may submit Offers for one or more products.

The resultant Contract will commence on or about February 1, 2023 for a five (5) year Contract term in accordance with the specifications and provisions contained herein.

2. AVIATION DEPARTMENT REPRESENTATIVE:

The Aviation Department Representative (ADR) for this Contract is **Alvin McDonnell, 602-683-3905**. The ADR or his designee will coordinate all work and will be the sole judge concerning acceptability and quality of work. The ADR or his designee will be consulted on any concerns and issues arising during the performance.

3. APPLICABLE LAWS AND STANDARDS:

Contractor must comply with the most current edition(s) of the International Air Travel Associations (IATA) standards below:

- 3.1. IATA Resolution 740
- 3.2. IATA Resolution 792
- 3.3. IATA Recommended Practice 1706c
- 3.4. IATA Recommended Practice 1706e
- 3.5. IATA Recommended Practice 1740a
- 3.6. IATA Recommended Practice 1740c
- 3.7. IATA Recommended Practice 1796



SECTION V- SCOPE

CITY OF PHOENIX
Aviation Department
Contracts & Services Division
2485 E. Buckeye Road
Phoenix, AZ 85034

4. GROUP I - COMMON USE PASSENGER PROCESSING SYSTEMS (CUPPS) PAPER

4.1. Standard Boarding Pass Paper:

This paper must meet the following specifications for boarding pass printer paper for any International Air Transport Association (IATA) compatible boarding pass printer.

4.1.1. 7.0 Mil paper

4.1.2. 3.25-inch width

4.1.3. Fanfold at 8.00-inch

4.1.4. 666.666 feet, which produce 1000 boarding passes

4.1.5. Perforation every 8.00-inch

4.1.6. Active surface located on top

4.1.7. Domestic paper only

4.2. 21" Standard Bag Tag Paper:

This paper must meet the following specification for bag tag printing for any IATA standard capable bag tag printer.

4.2.1. Ticket width: label stock 2 inches

4.2.2. Ticket length: 21-inch

4.2.3. Ticket paper weight: combined sticker and back - 40 lb.

4.2.4. Peel off adhesive tabs, IATA standard, small tabs lead off roll first

4.2.5. Single color print on liner, IATA standard airline instructions

4.2.6. 3-inch core

4.2.7. 2.13-inch web, perf and sensor holes

4.3. Standard 21" RFID Bag Tag Paper:

This paper must meet the following specification for bag tag printing for any IATA standard RFID capable bag tag printer.



SECTION V- SCOPE

CITY OF PHOENIX
Aviation Department
Contracts & Services Division
2485 E. Buckeye Road
Phoenix, AZ 85034

- 4.3.1. Ticket width: label stock 2 inches
- 4.3.2. Ticket length: 21 inches
- 4.3.3. Ticket paper weight: 45#/2.875 mm - 50#/3.2 mm
- 4.3.4. Peel off adhesive tabs, IATA standard, small tabs lead off roll first
- 4.3.5. Single color print on liner, IATA standard airline instructions
- 4.3.6. 3-inch core
- 4.3.7. 2.13-inch web, perf and sensor holes

4.4. Thermal Paper Roll:

- 4.4.1. Paper width: 3 1/8"
- 4.4.2. Paper length: 300'
- 4.4.3. Roll diameter: 3 1/4"
- 4.4.4. Core size: 7/16"

5. GROUP II- COMMON USE SELF-SERVICE (CUSS) PAPER PRODUCTS

5.1. Boarding Pass Paper:

This paper must meet the following specifications for boarding pass kiosk printer paper for any IATA compatible boarding pass printer. This defines the paper specifications for the Practical Automation ITK38 thermal printer installed in SITA kiosks that print ATB size tickets (82.5 mm x 203 mm).

Note: The printer has the "cutter option", and no "presenter".

- 5.1.1. Paper width: 203 mm +0/-1 mm (8.0 in. +0/-0.04 in.)
- 5.1.2. Outside diameter: between 152.4 and 203 mm (6 and 8 in.)
- 5.1.3. Inner diameter: 38.1 mm (1.5 in.)
- 5.1.4. Active surface is located on the inside of the roll
- 5.1.5. Paper core: The paper roll must not be attached to the inner core by any means such as glue or tape as it could pass through the rollers and print head and damage the printer.



SECTION V- SCOPE

CITY OF PHOENIX
Aviation Department
Contracts & Services Division
2485 E. Buckeye Road
Phoenix, AZ 85034

- 5.1.6.** Roll Paper Curl Considerations: The thermally active surface of roll paper must be the inside surface of the roll. This arrangement produces a smooth, direct route of the paper into the printer when the roll is mounted on the integral roll holder. Further, the upward curl aids in the formation of the loop for the transport-presenter or anti-jam paper deliver output devices.
- 5.1.7.** Registration Mark Location: Registration mark will be located on the bottom side. Refer to the diagram when specifying registration marked paper. Pay close attention to the inside/outside surfaces of the roll. The registration marks should be visible on the outside of the roll.
- 5.1.8.** Paper Form Type: The ITK38 supports continuous, or registration marked paper roll stock. The printer is factory set to sense registration marks. SITA recommends a registration mark every 82.5 mm (3.25 in.), as this is the width of an ATB ticket. Registration marks must be at least 76 mm (3.0 in.) apart.
- 5.1.9.** For variable length document printing, the paper supply is typically blank roll stock or roll stock with a continuous pre-printed background coloring, watermark, etc. For fixed sized documents, the paper supply can be blank or pre-printed, perforated, or pre-printed roll stock. All fixed length forms must contain a bottom side registration mark for synchronization. Refer to paragraph 6 Registration Mark Location for details of the registration mark.
- 5.1.10.** Continuous paper does not have a defined form size. It is typically blank; however, it may have top or bottom side background pre-printing. This background printing is used to enhance the appearance of the finished document.
- 5.1.11.** Registration marked forms have a form size defined by the distance between the marks. This marking is used to maintain the printer's mechanical synchronism with the paper stock. This type of form may also have top or bottom side pre- printing. The pre-printing may be background; however, it is more typically a form structure onto which variable field data is printed by the ITK38.
- 5.1.12.** Pre-Printed Paper Bottom Side Restrictions: All versions of the ITK38 utilize optical sensors to monitor the progress of paper through the system. Pre-printing of the paper in the area of these sensors should be avoided. High contrast ratio printing in these areas can interfere with this monitoring. See diagram for the locations of these restricted areas. These restrictions apply to continuous or registration marked paper.



SECTION V- SCOPE

CITY OF PHOENIX
Aviation Department
Contracts & Services Division
2485 E. Buckeye Road
Phoenix, AZ 85034

- 5.1.13. Pre-Printed Paper Top Side: Preprinting on the thermally active side of the paper should only be done using inks compatible with direct thermal printing. Ensure the host application only prints (thermally) in the un-inked areas.
- 5.1.14. Cutting Perforated Paper: The paper/registration mark sensor must be adjusted to cut a minimum of 1.59 mm (1/16 in.) behind the fold/perforation. Failure to do so can cause incomplete cutting of the document and/or miss-feeding of the document through the system. When adjusted correctly, this small “hinge” will be created at the trailing edge of the document by the perforation and cut.
- 5.1.15. Paper Form Type Recognition: The printer and the host PC can determine if the paper in the printer is continuous or registration marked.
- 5.1.16. Top and Bottom Margins: When printing on any physical document, there are practical limits for how close the printed data can come to the edge of the paper. The top and bottom unprintable margins are set at 3.175 mm (0.125 in.) for the ITK38 printer. The document printed will have these unprinted areas at the top and bottom of each document. For a complete understanding of a document’s length, these reserved unprintable margins need to be taken into consideration.

5.2. 21" Self-Tag RFID Bag Tag Paper for Kiosks

This paper must meet the following specification for bag tag printing for any IATA standard RFID capable bag tag printer.

- 5.2.1. Ticket width: label stock 2 inch
- 5.2.2. Ticket length: 21: inch
- 5.2.3. Ticket paper weight: 45#/2.875 mm - 50#/3.2 mm
- 5.2.4. Peel off adhesive NC, IATA standard, small tabs lead off roll first
- 5.2.5. Two color print on liner, IATA standard airline instructions
- 5.2.6. 3-inch core
- 5.2.7. 2.13-inch web, perf and sensor holes



SECTION V- SCOPE

CITY OF PHOENIX
Aviation Department
Contracts & Services Division
2485 E. Buckeye Road
Phoenix, AZ 85034

5.3. 21" Self-Tag, Bag Tag Paper for Kiosks

This paper must meet the following specification for bag tag printing for any IATA standard capable kiosk bag tag printer.

5.3.1. Ticket width: label stock 2 inch

5.3.2. Ticket length: 21 inches

5.3.3. Ticket paper weight: combined sticker and back - 40 lb.

5.3.4. Peel off adhesive tabs, IATA standard, small tabs lead off roll first

5.3.5. Two color print on liner, IATA standard airline instructions

5.3.6. 3-inch core

5.3.7. 2.13-inch web, perf and sensor holes

Remainder of page intentionally left blank.



SECTION V- SCOPE



CITY OF PHOENIX
Aviation Department
Contracts & Services Division
2485 E. Buckeye Road
Phoenix, AZ 85034

6. DIAGRAMS

6.1. CUSS Compliant Bag Tag

CUSS COMPLIANT BAGGAGE TAG

- All label corners 1/16" R
- Backers Extends 1/16" beyond label (on all sides)

-  Backside butt cut (to leave adhesive on claim stub)
-  Backside liner Perf (to act as fold point when peeling liner)

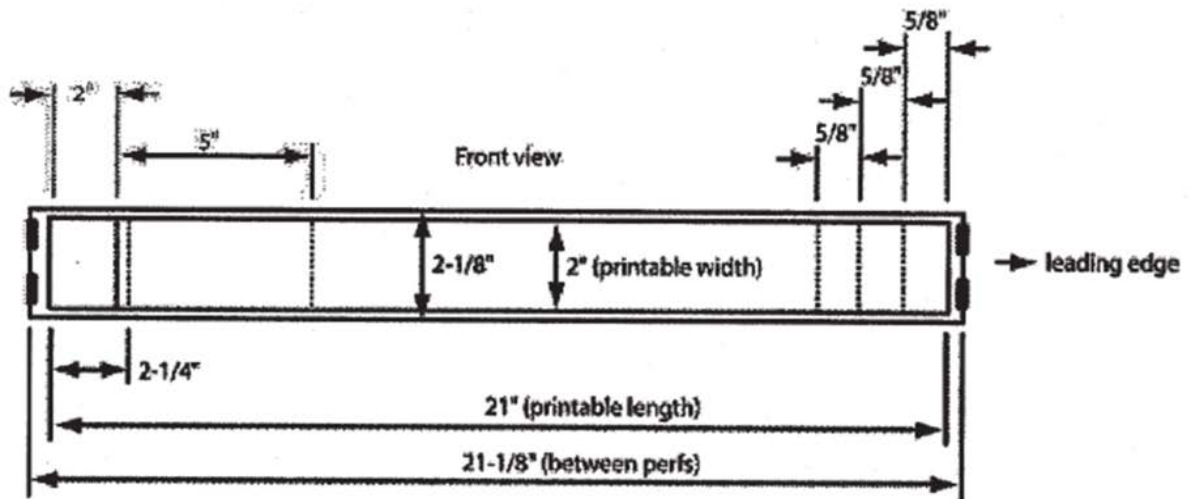

PERFORATION DETAILS

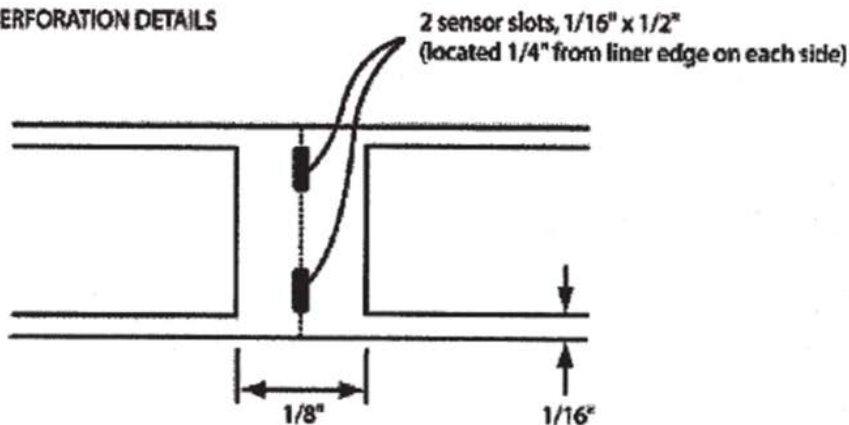



SECTION V- SCOPE

CITY OF PHOENIX
Aviation Department
Contracts & Services Division
2485 E. Buckeye Road
Phoenix, AZ 85034

6.2. CUSS/CUPPS RFID Bag Tag

CUSS/CUPPS Compliant RFID Baggage Tag

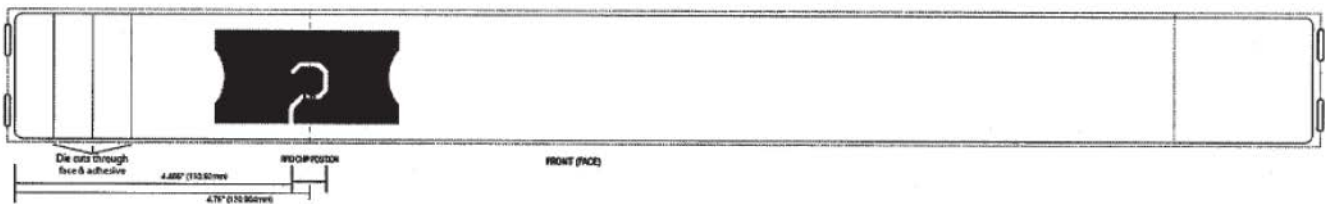

6.3. CUSS Boarding Pass Paper

Common Use Self-Service Boarding Pass Paper

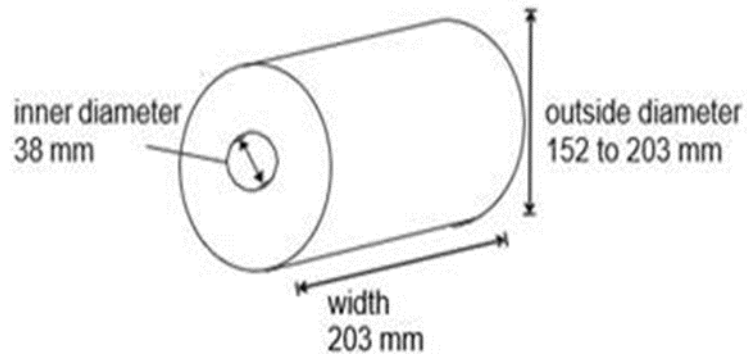



SECTION V- SCOPE

CITY OF PHOENIX
Aviation Department
Contracts & Services Division
2485 E. Buckeye Road
Phoenix, AZ 85034

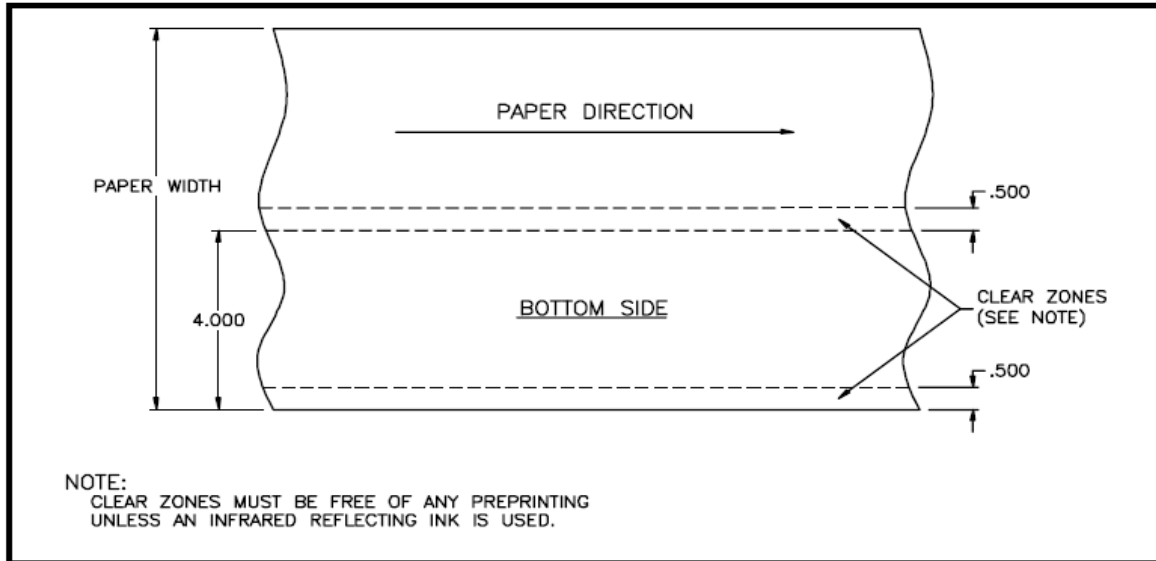

Measurements shown below are in inches

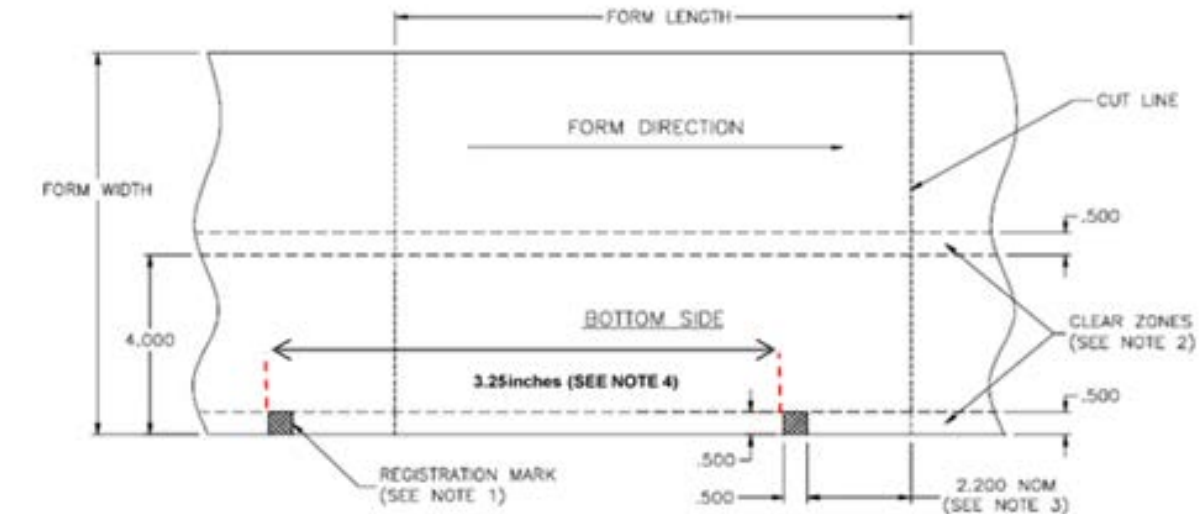

NOTES:

1. REGISTRATION MARK: 1/5 OF LIGHT BACKGROUND YIELDING 5:1 CONTRAST RATIO TO INFRARED LIGHT.
2. EXCEPT FOR REGISTRATION MARK, CLEAR ZONES MUST BE FREE OF ANY PREPRINTING UNLESS AN INFRARED
3. THE MARK SENSOR IS LOCATED TO CUT THE FORM APPROXIMATELY 2.200 AHEAD OF THE REGISTRATION MARK. IF PERFORATIONS ARE TO BE USED, THEY MUST BE PLACED .050 AHEAD OF THE CUTLINE (.250 AHEAD OF THE MARK).
4. THE DISTANCE BETWEEN THE EDGES OF THE REGISTRATION MARKS MUST BE 3.25 inches MEASURE FROM THE LEFT SIDE OF EACH REGISTRATION MARK AS SHOWN.



SECTION VI - SUBMITTALS

CITY OF PHOENIX
Aviation Department
Contracts & Services Division
2485 E. Buckeye Road
Phoenix, AZ 85034

SECTION VI – SUBMITTALS

1. SUBMISSION OF OFFER – Hard Copy Submission:

- 1.1. Refer to paragraph 4 under the “SECTION I – INSTRUCTIONS” of this Solicitation document.
1.2. Please submit one original, 2 copies, and one electronic copy (portable drive or CD) of the Submittal Section and all other required documentation.
1.3. Please submit only the Submittal Section with offer, do not submit a copy of the entire Solicitation document. The Offer will remain in effect for a period of 240 calendar days from the opening date and is irrevocable unless it is in the City’s best interest to release Offers.

2. SUBMISSION OF OFFER – Electronic Submission:

- 2.1. Refer to paragraph 5 under the “SECTION I – INSTRUCTIONS” of this Solicitation document.
2.2. Electronic Bid Submission via email: Offers is to be submitted electronically via email to the following email addresses: amy.m.turner@phoenix.gov AND avn.procurephx@phoenix.gov
2.3. The email subject line must include RFQu number and title. For example: AVN RFQu 23-021 Airline Common Use Paper II.

3. OFFER SUBMITTAL FORMAT:

The written Offer should be:

- Typewritten for ease of evaluation;
• Signed by an authorized representative of the Offeror;
• Submitted with contact information for the individual(s) authorized to negotiate with the City;
• Submitted in a binder, preferably using double-sided copying and at least 30% post-consumer content paper for hard copy submissions;
• Submitted with a table of contents and tabbed per the following major sections for hard copy submissions:

Table with 2 columns: Tab number and Description. Rows include: Tab 1 Table of Contents, Tab 2 Statement of Qualifications-Executive Summary, Service Rep Resume, Method of Approach, Tab 3 Samples, Tab 3 Entire Submittal Section including References, Tab 4 Signed Addenda, if applicable



SECTION VI - SUBMITTALS

CITY OF PHOENIX
Aviation Department
Contracts & Services Division
2485 E. Buckeye Road
Phoenix, AZ 85034

4. PROPOSED PRODUCTS:

Offerors are encouraged to submit one or more product offerings based on their ability to provide quality products that meet all specifications. Offerors are not required to provide all items within each group. Please identify all of the products you are submitting proposals for by checking the applicable box(es) below.

Offerors must check all products for which it is submitting its Statement of Qualifications.

- GROUP I – CUPPS Compliant**
 - Standard Boarding Pass Paper
 - 21” Standard Bag Tag
 - 21” RFID Bag Tag
 - Thermal Paper Roll for Gate Receipts
- GROUP II – CUSS Compliant**
 - Boarding Pass Paper
 - 21” Self-Tag for Kiosks
 - 21” RFID Self-Tag for Kiosks

5. COSTS AND PAYMENTS:

PAYMENT TERMS & OPTIONS: Offerors must choose an option, if a box is not checked, the City will **default to 0% - net 45 days**:

- Contractor offers a prompt payment discount of either _____% - 30 days or 0% – 45 days - to apply after receipt of invoice or final acceptance of the products (invoice approval), whichever date is later, starts the 30 days. If no prompt payment discount is offered, the default is 0%, net 45 days; effective after receipt of invoice or final acceptance of the products, whichever is later. **Payment terms offering a discount will not be considered in the price evaluation of your offer.**
- Contractor may be paid immediately upon invoice approval, if enrollment is made to the Single Use Account (SUA) Program, administered by the City's servicing bank ("Bank"). By checking this box, the vendor accepts transaction costs charged by their merchant bank and agrees not to transfer to the City those extra charges. The City will not pay an increase in our services for the SUA charges; if an audit uncovers an upcharge for the SUA charges the vendor will owe the City all costs. The vendor may opt-out of the SUA program once, but then may not rejoin during the same contract term. **For more information about the SUA program or to enroll, send email to mailbox.sua@phoenix.gov.**



SECTION VI - SUBMITTALS

**CITY OF PHOENIX
Aviation Department
Contracts & Services Division
2485 E. Buckeye Road
Phoenix, AZ 85034**

5. EMERGENCY 24-HOUR SERVICE CONTACT:

Name _____

Telephone Number _____

Alternate Contact _____

Telephone Number _____

6. PLACE OF BUSINESS:

Bidder's place of business will be an award factor in order to minimize the City's transportation and handling costs. If additional service locations are available or if different from the address in Offer Section, enter below:

Remainder of this page is intentionally left blank.



SECTION VI - SUBMITTALS

**CITY OF PHOENIX
Aviation Department
Contracts & Services Division
2485 E. Buckeye Road
Phoenix, AZ 85034**

7. YEARS IN BUSINESS AND REFERENCES:

Contractor certifies that it has experience in manufacturing and/or supplying common use paper for a **minimum of five (5)** consecutive years within the last ten (10) years immediately preceding issuance of this RFQu.

Contractor shall furnish the names, addresses, and telephone numbers of a minimum of three (3) firms or government organizations for which the Contractor is/or has provided airline common use paper products.

Company Name _____

Address _____

Reference _____

Telephone Number _____

Email address _____

Company Name _____

Address _____

Reference _____

Telephone Number _____

Email address _____

Company Name _____

Address _____

Reference _____

Telephone Number _____

Email address _____



SECTION VI - SUBMITTALS

**CITY OF PHOENIX
Aviation Department
Contracts & Services Division
2485 E. Buckeye Road
Phoenix, AZ 85034**

OFFER

TO THE CITY OF PHOENIX - The Undersigned hereby offers and agrees to furnish the material and or services in compliance with all terms, conditions, specifications, and addenda issued as a result of a Solicitation.

Arizona Sales Tax No. _____
Use Tax No. for Out-of-State Suppliers _____
City of Phoenix Sales Tax No. _____
Arizona Corporation Commission File No. _____

Taxpayer's Federal Identification No.: If recommended for contract award, Bidder agrees to provide its federal taxpayer identification number or as applicable its social security number to the City of Phoenix for the purposes of reporting to appropriate taxing authorities, monies paid by the City of Phoenix under the awarded contract. If the Bidder provides its social security number, the City will only share this number with appropriate state and federal officials. This submission is mandatory under 26 U.S.C. § 6041A.

Enter City's Registration System ID Number Located at City's eProcurement website (see SECTION I - INSTRUCTIONS - CITY'S REGISTRATION)	
---	--

Offeror has read, understands, and will fully and faithfully comply with this Solicitation, its attachments and any referenced documents. Offeror certifies that the prices offered were independently developed without consultation with any other Offeror or potential Offerors.

Authorized Signature

Date

Verify Name and type of company
(LLC, Inc., Sole Proprietor)

Printed Name and Title
(Member, Manager, President)

Address _____
City, State and Zip Code _____
Telephone Number _____
Company's Fax Number _____
Company's Toll Free # _____
Email Address _____



SECTION VI - SUBMITTALS

**CITY OF PHOENIX
Aviation Department
Contracts & Services Division
2485 E. Buckeye Road
Phoenix, AZ 85034**

ACCEPTANCE OF OFFER

The Offer is hereby accepted.

Contractor is now bound to sell the material(s) or service(s) listed by the Contract and based upon the Solicitation, including all terms, conditions, specifications, amendments, etc. and the Contractor's Offer as accepted by the City.

This Contract shall henceforth be referred to as Contract No. _____. The Contractor has been cautioned not to commence any billable work or provide any material or service under this contract until Contractor receives purchase order, or contract documentation.

THE CITY OF PHOENIX
an Arizona municipal corporation
JEFFREY BARTON, City Manager

By: _____
Michael D. Hughes
Deputy Aviation Director

Date: _____

Attest:

City Clerk

Approved as to form this 19th day of January 2017. This document has been approved as to form by the City Attorney and is on file with the City Clerk. It need not be submitted to the City Attorney for approval unless the form document is altered.

2332530



SECTION VI - SUBMITTALS

**CITY OF PHOENIX
Aviation Department
Contracts & Services Division
2485 E. Buckeye Road
Phoenix, AZ 85034**

CONFLICT OF INTEREST & SOLICITATION TRANSPARENCY FORM

This form must be signed and submitted to the City and all questions must be answered (or N/A) or your Offer may be considered non-responsive.

1. Name of person submitting this disclosure form.

First	MI	Last	Suffix
-------	----	------	--------

2. Contract Information

Solicitation # or Name: RFQu 23-021 Airline Common Use Paper II

3. Name of individual(s) or entity(ies) seeking a contract with the City (i.e. parties to the Contract)

4. List any individuals(s) or entity(ies) that are owners, partners, parent, sublessees, joint venture, or subsidiaries of the individual or entity listed in Question 3. Please include all Board members, executive committee members and officers for each entry. If not applicable, indicate N/A.



SECTION VI - SUBMITTALS

**CITY OF PHOENIX
Aviation Department
Contracts & Services Division
2485 E. Buckeye Road
Phoenix, AZ 85034**

5. List any individuals or entities that will be subcontractors on this contract or indicate N/A.

- Subcontractors may be retained, but not known as of the time of this submission.
- List of subcontracts, including the name of the owner(s) and business name:

6. List any attorney, lobbyist, or consultant retained by any individuals listed in Questions 3, 4, or 5 to assist in the proposal or seeking the resulting contract. If none, indicate N/A.

7. Disclosure of Conflict of Interest:

A. City Code Section 43-34

Are you aware of any fact(s) with regard to this Solicitation or resulting contract that would raise a “conflict of interest” issue under City Code Section 43-34?

“An elected City official or a City employee shall not represent any person or business for compensation before the City regarding any part of a procurement, including any resulting contract, if during the time the elected official is or was in office or the employee is or was employed by the City such elected official or employee played a material or significant role in the development of the Solicitation, any other part of the procurement, or the contract award.

- I am not aware of any conflict(s) of interest under City Code Section 43-34.
- I am aware of the following potential or actual conflict(s) of interest:



SECTION VI - SUBMITTALS

CITY OF PHOENIX
Aviation Department
Contracts & Services Division
2485 E. Buckeye Road
Phoenix, AZ 85034

B. ARS Sections 38-501 et. Seq. & City Charter Chapter 11

State law and the Phoenix City Charter and Code prohibit public officers or employees, their close relatives, and any businesses they, or their relatives, own from (1) representing before the City any person or business for compensation, (2) doing business with the City by any means other than through a formal procurement, and (3) doing business with the City without disclosing that the person has an interest in the contract. This prohibition extends to subcontracts on City contracts and also applies to parent, subsidiary, or partner businesses owned by a public officer or employee. See A.R.S. Sections 38-501 through 38-511, for more information (City Charter, Chapter 11, applies the state conflict-of-interest law to City employees).

Please note that any contract in place at the time a person becomes a public officer or employee may remain in effect. But the contract may not be amended, extended, modified, or changed in any manner during the officer's or employee's city service without following city administrative regulations.

Are you aware of any fact(s) with regard to this contract that would raise a "conflict of interest" issue under A.R.S. Sections 38-501 through 38-511 (See Arizona Revised Statutes regarding conflict of interest at www.azleg.gov).

- I am not aware of any conflict(s) of interest under Arizona Revised Statutes Sections 38-501 through 38-511.
- I am aware of the following conflict(s) of interest:

8. Acknowledgements

A. Solicitation Transparency Policy – No Contact with City Officials or Staff During Evaluation

- I understand that a person or entity who seeks or applies for a city contract, or any other person acting on behalf of that person or entity, is prohibited from contacting city officials and employees regarding the contract after a Solicitation has been posted.
- This "no-contact" provision only concludes when the contract is awarded at a City Council meeting. If contact is required with City official or employees, the contact will take place in accordance with procedures by the City. Violation of this prohibited contacts provision, set out in City Code Sections 2-190.4 and 43-36, by respondents, or their agents, will lead to **disqualification**.



SECTION VI - SUBMITTALS

**CITY OF PHOENIX
Aviation Department
Contracts & Services Division
2485 E. Buckeye Road
Phoenix, AZ 85034**

B. Fraud Prevention and Reporting Policy

- I acknowledge that the City has a fraud prevention and reporting policy and takes fraud seriously. I will report fraud, suspicion of fraud, or any other inappropriate action to: telephone no. 602-261-8999 or 602-534-5500 (TDD); or aud.integrity.line@phoenix.gov.

The purpose of the fraud policy is to maintain the City's high ethical standards. The policy includes a way for our business partners to report wrongdoing or bad behavior. Suspected fraud should be reported immediately to the Phoenix Integrity Line. The City has adopted a zero-tolerance policy regarding fraud.

OATH

I affirm that the statements contained in this form, including any attachments, to the best of my knowledge and belief are true, correct, and complete. Should any of the answers to the above questions change during the course of the contract, particularly as it relates to any changes in ownership, applicant agrees to update this form with the new information within 30 days of such changes. Failure to do so may be deemed a breach of contract.

PRINT NAME

TITLE

SIGNATURE

DATE

COMPANY (CORPORATION, LLC, ETC.) NAME and DBA



SECTION VII - EXHIBITS

CITY OF PHOENIX
Aviation Department
Contracts & Services Division
2485 E. Buckeye Road
Phoenix, AZ 85034

EXHIBIT A

SUPPLEMENTAL TERMS AND CONDITIONS TO ALL AIRPORT AGREEMENTS

1. Definitions

1.1 "Airport" means Phoenix Sky Harbor International Airport, Phoenix Deer Valley Airport, and/or Phoenix Goodyear Airport, according to the context of the contract.

1.2 "Contract" means all City of Phoenix Aviation Department contracts, subcontracts, agreements, leases, subleases, licenses, permits, concessions, and other documents, however denominated, that grant or convey a right or privilege on an Airport and to which this Exhibit is attached.

1.3 "Contractor" means all lessees, sublessees, licensees, permittees, consultants, concessionaires and other persons, firms, or corporations exercising a right or privilege on an Airport pursuant to a Contract and includes Contractor's heirs, personal representatives, successors, and assigns.

1.4 "Premises" means the area of an Airport occupied or used by Contractor pursuant to a Contract.

2. Federal Aviation Administration (FAA) Grant Assurances

2.1 Title VI of the Civil Rights Act of 1964 – Compliance with Nondiscrimination Requirements – 49 U.S.C. § 47123 and FAA Order 1400.11

During the performance of this Contract, Contractor agrees as follows:

A. Compliance with Regulations. Contractor will comply with the Title VI List of Pertinent Nondiscrimination Acts and Authorities (as provided in Section 7 below), as it may be amended from time to time, which is incorporated herein by reference and made a part of this Contract.

B. Nondiscrimination. With regard to the work performed by it under this Contract, Contractor will not discriminate on the grounds of race, color, or national origin in the selection and retention of subcontractors, including procurements of materials and leases of equipment. Contractor will not participate, directly or indirectly, in the discrimination prohibited by the Title VI List of Pertinent Nondiscrimination Acts and Authorities, including employment practices when this Contract covers any activity, project, or program set forth in Appendix B of 49 C.F.R. Part 21.



SECTION VII - EXHIBITS

CITY OF PHOENIX
Aviation Department
Contracts & Services Division
2485 E. Buckeye Road
Phoenix, AZ 85034

C. Solicitations for Subcontracts, Including Procurements of Materials and Equipment. In all Solicitations, either by competitive bidding or negotiation, made by Contractor for work to be performed under a subcontract, including procurements of materials or leases of equipment, each potential subcontractor or supplier will be notified by Contractor of Contractor's obligations under this Contract and the Title VI List of Pertinent Nondiscrimination Acts and Authorities on the grounds of race, color, or national origin.

D. Information and Reports. The Contractor will provide all information and reports required by the Title VI List of Pertinent Nondiscrimination Acts and Authorities, and directives issued pursuant thereto and will permit access to its books, records, accounts, other sources of information, and its facilities as may be determined by the City of Phoenix or the FAA to be pertinent to ascertain compliance with the Title VI List of Pertinent Nondiscrimination Acts and Authorities and instructions. Where any information required of Contractor is in the exclusive possession of another who fails or refuses to furnish the information, Contractor will so certify to the City of Phoenix or the FAA, as appropriate, and will set forth what efforts Contractor has made to obtain the information.

E. Sanctions for Noncompliance. In the event of Contractor's noncompliance with the nondiscrimination provisions of this Contract, the City of Phoenix will impose such Contract sanctions as it or the FAA may determine to be appropriate, including:

- (i) Withholding payments to Contractor under this Contract until Contractor complies, and/or
- (ii) Cancelling, terminating, or suspending this Contract, in whole or in part.

F. Covenant Running with the Land. Contractor for itself and its heirs, personal representatives, successors, and assigns, as a part of the consideration for this Contract, hereby covenants and agrees that, in the event facilities are constructed, maintained, or otherwise operated on the property described in this Contract for a purpose for which a FAA activity, facility, or program is extended or for another purpose involving the provision of similar services or benefits, Contractor will maintain and operate such facilities and services in compliance with all requirements imposed by the Nondiscrimination Acts and Regulations listed in the Title VI List of Pertinent Nondiscrimination Acts and Authorities (as may be amended) such that no person on the grounds of race, color, or national origin will be excluded from participation in, denied the benefits of, or be otherwise subjected to discrimination in the use of said facilities. In the event of a breach of any of the above Nondiscrimination covenants, the City of Phoenix will have the right to terminate this Contract and to enter, re-enter and repossess the property and facilities thereon and hold the same as if this Contract had never been made or issued.



SECTION VII - EXHIBITS

CITY OF PHOENIX
Aviation Department
Contracts & Services Division
2485 E. Buckeye Road
Phoenix, AZ 85034

G. Incorporation of Provisions. Contractor will include the provisions of paragraphs A through F in every subcontract, including procurements of materials and leases of equipment, unless exempt by the Title VI List of Pertinent Nondiscrimination Acts and Authorities, the Regulations, and directives issued pursuant thereto. Contractor will take action with respect to any subcontract or procurement as the City of Phoenix or the FAA may direct as a means of enforcing such provisions, including sanctions for noncompliance, provided, however, that if Contractor becomes involved in, or is threatened with litigation by a subcontractor or supplier because of such direction, Contractor may request the City of Phoenix to enter into any litigation to protect the interests of the City of Phoenix. In addition, Contractor may request the United States to enter into the litigation to protect the interests of the United States.

2.2 General Civil Rights Provisions – 49 U.S.C. § 47123

A. Sponsor Contracts. Contractor agrees to comply with pertinent statutes, executive orders, and such rules as are promulgated to ensure that no person shall, on the grounds of race, creed, color, national origin, sex, age, or disability, be excluded from participating in any activity conducted with or benefiting from federal assistance. This provision binds Contractor and subtier contractors from the bid Solicitation period through the completion of this Contract. This provision is in addition to that required of Title VI of the Civil Rights Act of 1964.

B. Sponsor Lease Agreements and Transfer Agreements. Contractor agrees to comply with pertinent statutes, executive orders, and such rules as are promulgated to ensure that no person shall, on the grounds of race, creed, color, national origin, sex, age, or disability, be excluded from participating in any activity conducted with or benefiting from federal assistance, including Section 504 of the Rehabilitation Act of 1973 and the Americans with Disabilities Act of 1990. If Contractor transfers its obligations to another, then the transferee is obligated in the same manner as Contractor. This provision obligates Contractor or its transferee for the period during which the property is owned, used, or possessed by Contractor and the City of Phoenix remains obligated to the FAA. This provision is in addition to that required by Title VI of the Civil Rights Act of 1964.

2.3 Economic Nondiscrimination – 49 U.S.C. § 47107

In any Contract under which a right or privilege on the Airport is granted to a Contractor to conduct or to engage in any aeronautical activity for furnishing services to the public, Contractor shall:

A. Furnish its services on a reasonable, and not unjustly discriminatory basis to all users of the Airport, and



SECTION VII - EXHIBITS

CITY OF PHOENIX
Aviation Department
Contracts & Services Division
2485 E. Buckeye Road
Phoenix, AZ 85034

B. Charge reasonable, and not unjustly discriminatory prices for each unit or services, provided that Contractor may be allowed to make reasonable and non-discriminatory discounts, rebates, or other similar types of price reductions to volume purchasers. Non-compliance with this requirement shall be a material breach of this Contract for which the City of Phoenix shall have the right to terminate this Contract and any estate created herewith without liability therefor or, at the election of the City of Phoenix or the United States shall have the right to judicially enforce said requirement.

2.4 Disadvantaged Business Enterprise Requirements – 49 C.F.R. Part 26

A. Contract Assurance (§ 26.13). To the extent that this Contract is covered by 49 C.F.R. Part 26, Contractor agrees that this Contract is subject to the requirements of the U.S. Department of Transportation regulations at 49 C.F.R. Part 26. Contractor or its subcontractor shall not discriminate on the basis of race, color, national origin, or sex in the performance of this Contract. Contractor shall carry out applicable requirements of 49 C.F.R. Part 26 in the award and administration of DOT-assisted contracts. Failure by Contractor to carry out these requirements is a material breach of this Contract, which may result in the termination of this Contract or such other remedy as the City of Phoenix deems appropriate, which may include (i) withholding monthly progress payments, (ii) assessing sanctions, (iii) liquidated damages, and/or (iv) disqualifying Contractor from future bidding as non-responsible. Contractor agrees to include the foregoing statement in any subsequent contract that it enters into and cause those businesses to similarly include the statement in further agreements.

B. Prompt Payment (§ 26.29). Contractor agrees to pay each subcontractor under this Contract for satisfactory performance of its contract not later than seven (7) days from the receipt of each payment Contractor receives from City of Phoenix. Contractor agrees further to return retainage payments to each subcontractor within seven (7) days after the subcontractor's work is satisfactorily completed. Any delay or postponement of payment from the above-referenced time frame may occur only for good cause following written approval of the City of Phoenix. This clause applies to both DBE and non-DBE subcontractors.

2.5 Airport Concessions Disadvantaged Business Enterprise Requirements – 49 C.F.R. Part 23

Contract Assurance (§ 23.9). To the extent that this Contract is a concession agreement covered by 49 C.F.R. Part 23, Contractor agrees that it will not discriminate against any business owner because of the owner's race, color, national origin, or sex in connection with the award or performance of any concession agreement, management contract, or subcontract, purchase or lease agreement, or other agreement covered by 49 C.F.R. Part 23. Contractor agrees to include the above statements in any subsequent concession agreement or contract covered by 49 C.F.R. Part 23 that it enters into and cause those businesses to similarly include the statements in further agreements.



SECTION VII - EXHIBITS

CITY OF PHOENIX
Aviation Department
Contracts & Services Division
2485 E. Buckeye Road
Phoenix, AZ 85034

2.6 Miscellaneous

A. Contractor agrees that it will undertake an affirmative action plan in conformance with 14 C.F.R. Part 152, Subpart E (Nondiscrimination in Airport Aid Program), to ensure that no person shall on the grounds of race, creed, color, national origin, or sex be excluded from participating in any employment, contracting, or leasing activities covered in 14 C.F.R. Part 152, Subpart E. Contractor assures that no person will be excluded on such grounds from participating in or receiving the services or benefits of any program or activity covered by Subpart E. Contractor further agrees that it will require its covered suborganizations to provide assurances to Contractor that they similarly will undertake affirmative action programs and that they will require like assurances from their suborganizations as required by 14 C.F.R. Part 152, Subpart E.

B. City of Phoenix reserves the right to further develop, improve, repair, and alter the Airport and all roadways, parking areas, terminal facilities, landing areas, and taxiways, as it may reasonably see fit, free from any and all liability to Contractor for loss of business or damages of any nature whatsoever to Contractor occasioned during the making of such improvements, repairs, alterations, and additions.

C. The City of Phoenix reserves the right, but is not obligated to Contractor, to maintain and keep in repair the landing area of the Airport and all publicly-owned facilities of the Airport, together with the right to direct and control all activities of Contractor in this regard.

D. Contractor acknowledges that this Contract is subordinate to any existing or future agreement between the City of Phoenix and the United States concerning the development, operation, or maintenance of the Airport. If the FAA or its successors require modifications or changes in the Contract as a condition to obtaining funds for improvements at the Airport or as a requirement of any prior grants, Contractor hereby consents to any and all such modifications and changes as may be reasonably required and agrees that it will adopt any such modifications and changes as part of this Contract.

E. This Contract is subordinate to the reserved right of the City of Phoenix and its successors and assigns to occupy and use for the benefit of the public the airspace above the Premises for the right of flight for the passage of aircraft. This public right of flight includes the right to cause in the airspace any noise inherent in the operation of any aircraft through the airspace or in landing at, taking off from, or operating at an Airport.



SECTION VII - EXHIBITS

CITY OF PHOENIX
Aviation Department
Contracts & Services Division
2485 E. Buckeye Road
Phoenix, AZ 85034

F. Contractor agrees to comply with the notification and review requirements, as required by 14 C.F.R. Part 77 (Safe, Efficient Use, and Preservation of the Navigable Airspace), if future construction of a structure is planned for the Premises or a planned modification of a structure on the Premises. Contractor shall submit the required FAA Form 7460-1 (Notice of Proposed Construction or Alteration) and provide documentation showing compliance with the federal requirements. After the FAA has completed the aeronautical study, Contractor shall provide to the City of Phoenix the FAA determination letter on proposed construction and any impact to air navigation. Contractor covenants for itself and its successors and assigns that it will not erect or permit the erection of any structure or permit the growth of any tree on the Premises above the mean sea level elevation for (1) Phoenix Sky Harbor International Airport, 1,134 feet, (2) Phoenix Goodyear Airport, 968 feet, and (3) Phoenix Deer Valley Airport, 1,476 feet. As a remedy for the breach of the covenant, the City of Phoenix reserves the right to enter the Premises and remove the offending structure or cut the offending tree at Contractor's expense.

G. Contractor, by accepting this Contract, covenants for itself and its successors and assigns, that no use will be made of the Premises that might in any manner interfere with the landing and taking off of aircraft from the Airport or otherwise constitute a hazard to air navigation. As a remedy for the breach of the covenant, the City of Phoenix reserves the right to enter the Premises and abate the interference at Contractor's expense.

H. Contractor agrees that nothing in this Contract may be construed to grant or authorize the granting of an exclusive right within the meaning of 49 U.S.C. § 40103(e) (No exclusive rights at certain facilities).

I. This Contract is subordinate to whatever rights the United States now has or in the future may acquire affecting the control, operation, regulation, and taking-over of the Airport or the exclusive or non-exclusive use of the Airport by the United States during a time of war or national emergency.

J. If this Contract involves construction, Contractor shall carry out the project in accordance with FAA airport design, construction, and equipment standards and specifications current on the date of project approval.

K. Contractor is encouraged to use fuel and energy conservation practices.



SECTION VII - EXHIBITS

CITY OF PHOENIX
Aviation Department
Contracts & Services Division
2485 E. Buckeye Road
Phoenix, AZ 85034

3. **Immigration Reform and Control Act of 1986 (IRCA)**

Contractor agrees that IRCA (Public Law 99-603) applies to it. Contractor shall comply with the provisions of IRCA as it applies to its activities under this Contract and to permit the City of Phoenix to inspect its personnel records to verify its compliance.

4. **Conflict of Interest**

Contractor agrees that the City of Phoenix may cancel this Contract pursuant to Arizona Revised Statutes (A.R.S.) § 38-511 (Cancellation of political subdivision and state contracts).

5. **Legal Worker Requirements**

The City is prohibited by A.R.S. § 41-4401 from awarding an agreement to any contractor who fails, or whose subcontractors fail, to comply with A.R.S. § 23-214(A) (Verification of employment eligibility; e-verify program). Therefore, Contractor agrees that:

A. Contractor and each subcontractor it uses warrants their compliance with all federal immigration laws and regulations that relate to their employees and their compliance with § 23-214(A).

B. A breach of warranty under paragraph A above shall be deemed a material breach of this Contract and is subject to penalties up to and including termination of the Agreement.

C. The City of Phoenix retains the legal right to inspect the papers of Contractor or its subcontractor employees who work on this Contract to ensure that Contractor or its subcontractors are complying with the warranty under paragraph A above.

6. **City of Phoenix Equal Employment Opportunity Requirement**

6.1 If Contractor is by this Contract a supplier to or lessee of the City, then the requirements of the Phoenix City Code, Chapter 18, Article V applies, including the agreement that:



SECTION VII - EXHIBITS

CITY OF PHOENIX
Aviation Department
Contracts & Services Division
2485 E. Buckeye Road
Phoenix, AZ 85034

“Any supplier/lessee in performing under this contract shall not discriminate against any worker, employee or applicant, or any member of the public, because of race, color, religion, sex, national origin, age, or disability, nor otherwise commit an unfair employment practice. The supplier and/or lessee shall ensure that applicants are employed, and employees are dealt with during employment without regard to their race, color, religion, sex, national origin, age, or disability, and shall adhere to a policy to pay equal compensation to men and women who perform jobs that require substantially equal skill, effort, and responsibility, and that are performed within the same establishment under similar working conditions. Such action shall include but not be limited to the following: employment, promotion, demotion or transfer, recruitment or recruitment advertising, layoff, or termination; rates of pay or other forms of compensation; and selection for training; including apprenticeship. The supplier further agrees that this clause will be incorporated in all subcontracts with all labor organizations furnishing skilled, unskilled and union labor, or who may perform any such labor or services in connection with this contract.”

Supplier/lessee further agrees that this clause will be incorporated in all subcontracts, job-consultant agreements or subleases of this agreement entered into by supplier/lessee.

If the supplier/lessee employs more than 35 employees, the following language shall be included as the last paragraph to the clause above:

“The supplier/lessee further agrees not to discriminate against any worker, employee or applicant, or any member of the public, because of sexual orientation or gender identity or expression and shall ensure that applicants are employed, and employees are dealt with during employment without regard to their sexual orientation or gender identity or expression.”

6.2 Documentation. Suppliers and lessees may be required to provide additional documentation to the Equal Opportunity Department affirming that a nondiscriminatory policy is being utilized.



SECTION VII - EXHIBITS

CITY OF PHOENIX
Aviation Department
Contracts & Services Division
2485 E. Buckeye Road
Phoenix, AZ 85034

6.3 Monitoring. The Equal Opportunity Department shall monitor the employment policies and practices of suppliers and lessees subject to this Section 3 as deemed necessary. The Equal Opportunity Department is authorized to conduct on-site compliance reviews of selected firms, which may include an audit of personnel and payroll records, if necessary.

7. Title VI List of Pertinent Nondiscrimination Acts and Authorities

During the performance of this Contract, Contractor agrees to comply with all federal, state, and local nondiscrimination laws, rules, and regulation, including the following:

7.1 Title VI of the Civil Rights Act of 1964 (42 U.S.C. § 2000d) (prohibits discrimination on the basis of race, color, or national origin).

7.2 49 C.F.R. Part 21 (Nondiscrimination in Federally-Assisted Programs of the Department of Transportation—Effectuation of Title VI of the Civil Rights Act of 1964).

7.3 The Uniform Relocation Assistance and Real Property Acquisition Policies Act of 1970, (42 U.S.C. §§ 4601, *et seq.*) (prohibits unfair treatment of persons displaced or whose property has been acquired because of federal or federal aid programs and projects).

7.4 Section 504 of the Rehabilitation Act of 1973 (29 U.S.C. §§ 701, *et seq.*), as amended (prohibits discrimination on the basis of disability), and 49 C.F.R. Part 27 (Nondiscrimination on the Basis of Disability in Programs or Activities Receiving Federal Financial Assistance).

7.5 The Age Discrimination Act of 1975, as amended (42 U.S.C. §§ 6101, *et seq.*) (prohibits discrimination on the basis of age). Airport and Airway Improvement Act of 1982 (49 U.S.C. § 47123), as amended (prohibits discrimination based on race, creed, color, national origin, or sex).

7.6 The Civil Rights Restoration Act of 1987 (Public Law 100-209) (broadened the scope, coverage, and applicability of Title VI of the Civil Rights Act of 1964, the Age Discrimination Act of 1975, and Section 504 of the Rehabilitation Act of 1973 by expanding the definition of the terms “programs or activities” to include all of the programs or activities of the federal-aid recipients, sub-recipients, and contractors, whether the programs or activities are federally funded or not).



SECTION VII - EXHIBITS

CITY OF PHOENIX
Aviation Department
Contracts & Services Division
2485 E. Buckeye Road
Phoenix, AZ 85034

7.7 Titles II and III of the Americans with Disabilities Act of 1990 (42 U.S.C. §§ 12101, *et seq.*), which prohibit discrimination on the basis of disability in the operation of public entities, public and private transportation systems, places of public accommodation, and certain testing entities as implemented by U.S. Department of Transportation regulations at 49 C.F.R. Part 37 (Transportation Services for Individual with Disabilities) and Part 38 (Americans with Disabilities Act Accessibility Specification for Transportation Vehicles).

7.8 Executive Order 12898 (Federal Actions to Address Environmental Justice in Minority Populations and Low-Income Populations), which ensures nondiscrimination against minority populations by discouraging programs, policies, and activities with disproportionately high and adverse human health or environmental effects on minority and low-income populations.

7.9 Executive Order 13166 (Improving Access to Services for Persons with Limited English Proficiency) and resulting agency guidance and national origin discrimination includes discrimination because of limited English proficiency (LEP). To ensure compliance with Title VI, you must take reasonable steps to ensure that LEP persons have meaningful access to your programs (70 Fed. Reg. at 74087 to 74100).

7.10 Title IX of the Education Amendments of 1972 (20 U.S.C. §§ 1681, *et seq.*), as amended, which prohibits you from discriminating because of sex in education programs or activities.

2068157
Revised 2/1/19