

Pre-Offer Meeting

BAGGAGE HANDLING SYSTEMS – OPERATIONS, MAINTENANCE, REPAIR AND CONTROLS SYSTEM DESIGN, PROGRAMMING, AND INTEGRATION SERVICES

AVN RFP 24-0156

March 18, 2024
9:00 A.M.
via WebEx

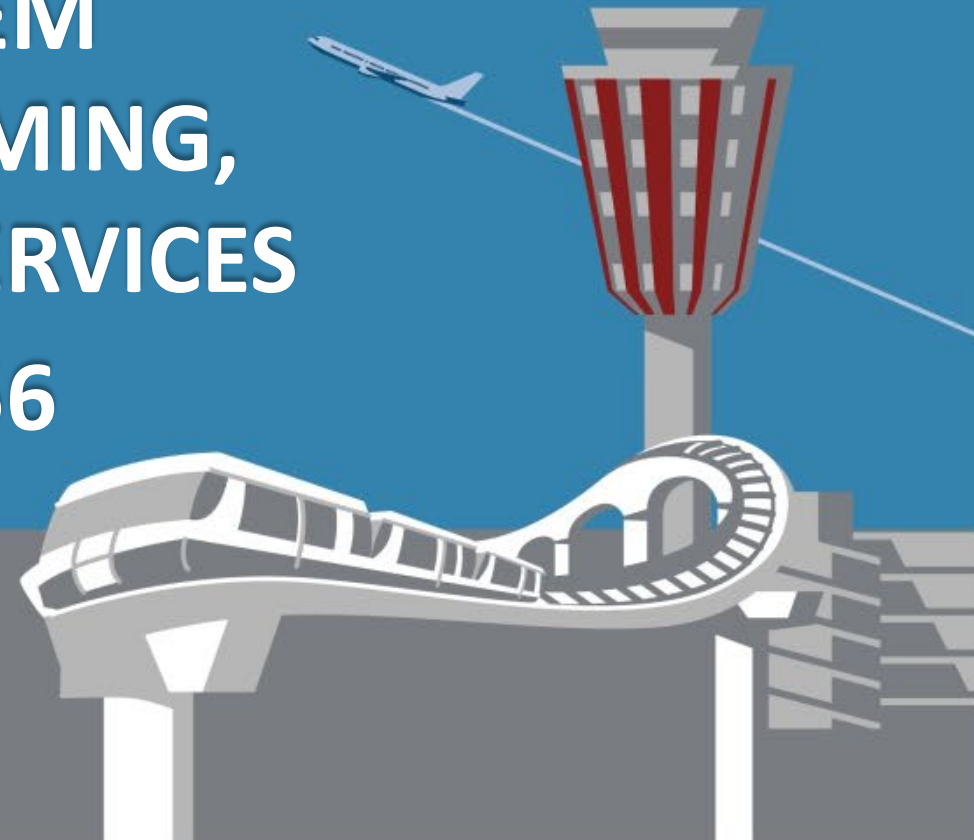



Welcome & Housekeeping



- ✈ Your Device is Automatically Muted.
- ✈ Use the “Chat” Function to Submit Your Questions.
- ✈ Questions will be answered at the end of the Presentation.
- ✈ Presentation will be available at:

<https://solicitations.phoenix.gov/Solicitations/Details/1742>



Agenda

- Introductions
- Solicitation Transparency Policy
- Site Tour
- RFP Timeline
- Minimum Qualifications
- Evaluation Criteria
- Submittals
- Scope Overview
- Questions

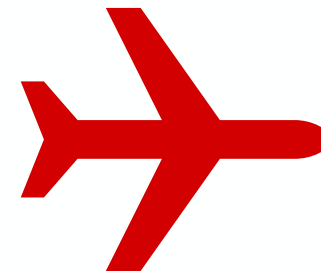
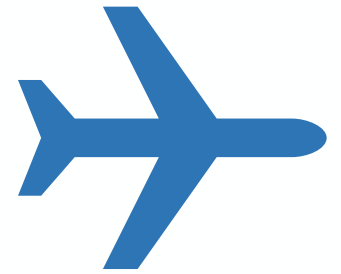
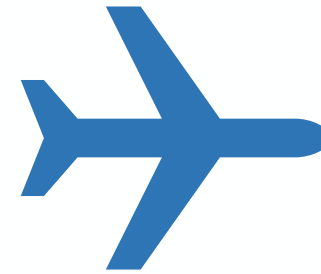



✈️ **Contracts and Services Division**

Annie Sleeper, Contracts Specialist II*Lead

✈️ **Facilities and Services Division**

Gary Lovgren, Aviation Superintendent

Jerry Oakes, Section Head / Baggage Handling Systems / EDS

Linda Duarte, Special Projects Administrator

Alicia Young, Facilities Contract Manager



Solicitation Transparency Policy



OFFERORS THAT VIOLATE THIS POLICY WILL BE DISQUALIFIED!

All communication must be directed to the Procurement Officer.

Effective

Date/Time Solicitation is issued.
February 26, 2023

Discussion & Requests

Only discuss matters of this RFP with the
Procurement Officer.

Phoenix City Code

Chapter 43, Section 43-36

Public Meeting

Discussion may occur with City staff in a Public
Meeting, requested through Procurement Officer

Policy Ends

City Council approves Contract award.
Projected September 2024.



This Pre-Offer Conference
and the Site Tour are
MANDATORY.

If joining today by phone, you must email
busopps.aviation@phoenix.gov
to be included as an attendee.



Mandatory Site Tour



Date/Time: March 20, 2024
9:00 a.m.

Register By: March 18, 2024
3:00 p.m.

annie.sleeper@phoenix.gov

**IMPORTANT
INFORMATION**

- Attendees subject to TSA screening, including inspection of accessible property.
- Valid government-issued picture ID required or active SIDA badge.
- No prohibited items allowed.
- No pictures or video are allowed.



Written Questions ONLY

- Written answers supersede verbal answers.
- All questions and responses will be published via an addendum.

Q&A and Addendums Available at:

<https://solicitations.phoenix.gov/Solicitations/Details/1742>





Questions Deadline

- **Monday, March 25, 2024**
- **5:00 P.M. local Arizona time.**
- Email: avn.solicitations@phoenix.gov and annie.sleeper@phoenix.gov.
- Include the RFP Number and Title in the email.



Answers Posted:

- <https://solicitations.phoenix.gov/Solicitations/Details/1742>



RFP Overview: Addenda



- ➔ Changes to this RFP will be an addendum, available at:
<https://solicitations.phoenix.gov/Solicitations/Details/1742>
- ➔ Must acknowledge receipt, sign, and return addendum with Offer.
- ➔ If addendum with material changes is not signed and submitted with Offer, Offer will be deemed non-responsive and rejected.
- ➔ Offerors' responsibility to visit the City's website for update(s) to this solicitation including all addendums.



DEADLINE

***Monday, April 29, 2024
at 3:00 P.M.
Local Arizona Time**

LATE OFFERS WILL BE DISQUALIFIED

*All Dates and Time are Subject to Change



RFP Overview: Submittal Location



Physical Submittal

Aviation Headquarters
2485 East Buckeye Road
Phoenix, AZ 85034

Monday – Friday, 8:00 a.m. to 5:00 p.m.



RFP Overview: Submittal Location



Electronic Submittal

Submit Offers via email to:

avn.solicitations@phoenix.gov and annie.sleeper@phoenix.gov

File size limitation of 100 mb.



Meeting Minimum Qualifications:

- ➔ Must meet Minimum Qualifications (MQ).
- ➔ Demonstrate in Offer.
- ➔ Failure to meet MQ equals a non-responsive Offer.



Minimum Qualifications:

MAY NOT USE SUBCONTRACTOR EXPERIENCE

1. Minimum five consecutive years in last 10 years providing BHS operation, maintenance, and repair services.
2. Minimum five consecutive years in last 10 years handling at least three million outbound bags annually at medium or large hub airport.
3. On-site Manager: minimum of two years in last five years handling at least three million outbound bags annually at medium or large hub airport.
4. In good standing with the City.



Minimum Qualifications:

MAY USE SUBCONTRACTOR EXPERIENCE

1. Minimum five consecutive years in last 10 years providing control systems design, programming and integration services, including a Central Control Room (CCR) environment.
 - Exp. with baggage handling control systems is preferred, not required.
2. Must have experience with Rockwell Automation software.



RFP Overview: Bid Price Schedule



Offeror must submit a completed Exhibit D – Pricing Proposal.
Failure to complete will result in a non-responsive determination.

A. Baggage Handling Systems Operations, Maintenance, and Repair Services:

Item No.	Description	Number of Months	Monthly Fee	Total Price
1.	Terminal 3 – Inbound (Jam Clearance only)	60	\$ -	\$ -
2.	Terminal 3 – Outbound	60	\$ -	\$ -
3.	Terminal 4 – Inbound (Jam Clearance only)	60	\$ -	\$ -
4.	Terminal 4 International Concourse – FIS Inbound	60	\$ -	\$ -
5.	Terminal 4 International Concourse – Outbound	60	\$ -	\$ -
6.	Terminal 4 International Concourse – Recheck Outbound	60	\$ -	\$ -
Grand Total				\$ -

B. Baggage Handling Control Systems Design, Programming, and Integration Services:

Item No.	Description	Estimated Aggregate	Hourly Labor Rate	Total Price
1.	Labor Hours	5,000	\$ -	\$ -
Grand Total				\$ -



RFP Overview: Bid Price Schedule



Offeror must submit a completed Exhibit D – Pricing Proposal.
Failure to complete will result in a non-responsive determination.

C-1. Ancillary Services

Item No.	Description	Hourly Rate
1.	Jam Runner	\$ -
2.	T3 and T4 Inbound Maintenance Services (hourly rate per employee performing services)	\$ -
3.	Mechanic	\$ -
4.	Task Order Services	\$ -
5.	Bio-Alignment of Luggage, Terminal 3 (At start up to shutdown 4:00 AM - 12:00 AM, Monday-Sunday)	\$ -
6.	Bio-Alignment of Luggage, Terminal 4	\$ -
7.	Removal of Old or Abandoned Equipment	\$ -

C-2. Subcontracting Work

Item No.	Description	Hourly Rate
1.	Subcontracting Labor Hours	\$ -

C-3. Optional Baggage Handling Services

Item No.	Description	Monthly Fee
1.	Terminal 4 North – Outbound (American Airlines) Includes oversize system	\$ -
2.	Terminal 4 South – Outbound (Southwest Airlines)	\$ -

C-4. Parts and Materials

Item No.	Description	Discount
1.	Materials, Parts, and Components (Discount off List Price)	%



Refer to AVN RFP 24-0156 for specifics details.

OFFEROR'S PROPOSAL

Method of Approach to Scope of Services

Fee Schedule (Exhibit D)

Qualifications and Experience of Firm

Qualifications and Experience of Proposed On-Site Manager

Required Submittals Forms

Addenda - Signed



Refer to AVN RFP 24-0156 for specific details.

**Method of Approach to
Scope of Services**

350 Points

Fee Schedule

250 Points

**Qualifications and
Experience of Firm**

225 Points

**Qualifications and
Experience of Proposed
On-Site Manager**

175 Points



Award Recommendation

- Projected July 2024
- <https://solicitations.phoenix.gov/Solicitations/Details/1742>



Protest Period:

- Within seven (7) days after Award Recommendation posting.
- See Section 2.19 – Protest Period of RFP



Contract Start Date:

→ November 1, 2024

Contract Term:

→ Five years

→ Two One-Year Options



Scope Overview

Facilities and Services Division





Project Description

The City of Phoenix is seeking Operation, Maintenance, Repair, and Control Services for the Baggage Handling Systems at Phoenix Sky Harbor International Airport (PHX). PHX is ranked as a top ten airport and has been named the top airport in the nation among large airports by the Wall Street Journal. To maintain the highest levels of service, safety, and efficiency, it will be necessary for staff to be directed by an engaged, proactive management team that implements continuous improvements employing best practices.



The successful Contractor will provide Operation, Maintenance, and Repair Services for the Baggage Handling Systems (BHS) with the following services:

- Supervision
- Labor
- Material
- Transportation
- Equipment
- Controls



The Contractor is required to service the BHS in the following locations:

- Terminal 3 – Inbound
- Terminal 3 – Outbound
- Terminal 4 – Inbound
- Terminal 4 International – FIS Inbound
- Terminal 4 International – Outbound
- Terminal 4 International – Recheck Outbound



SKY HARBOR CAMPUS

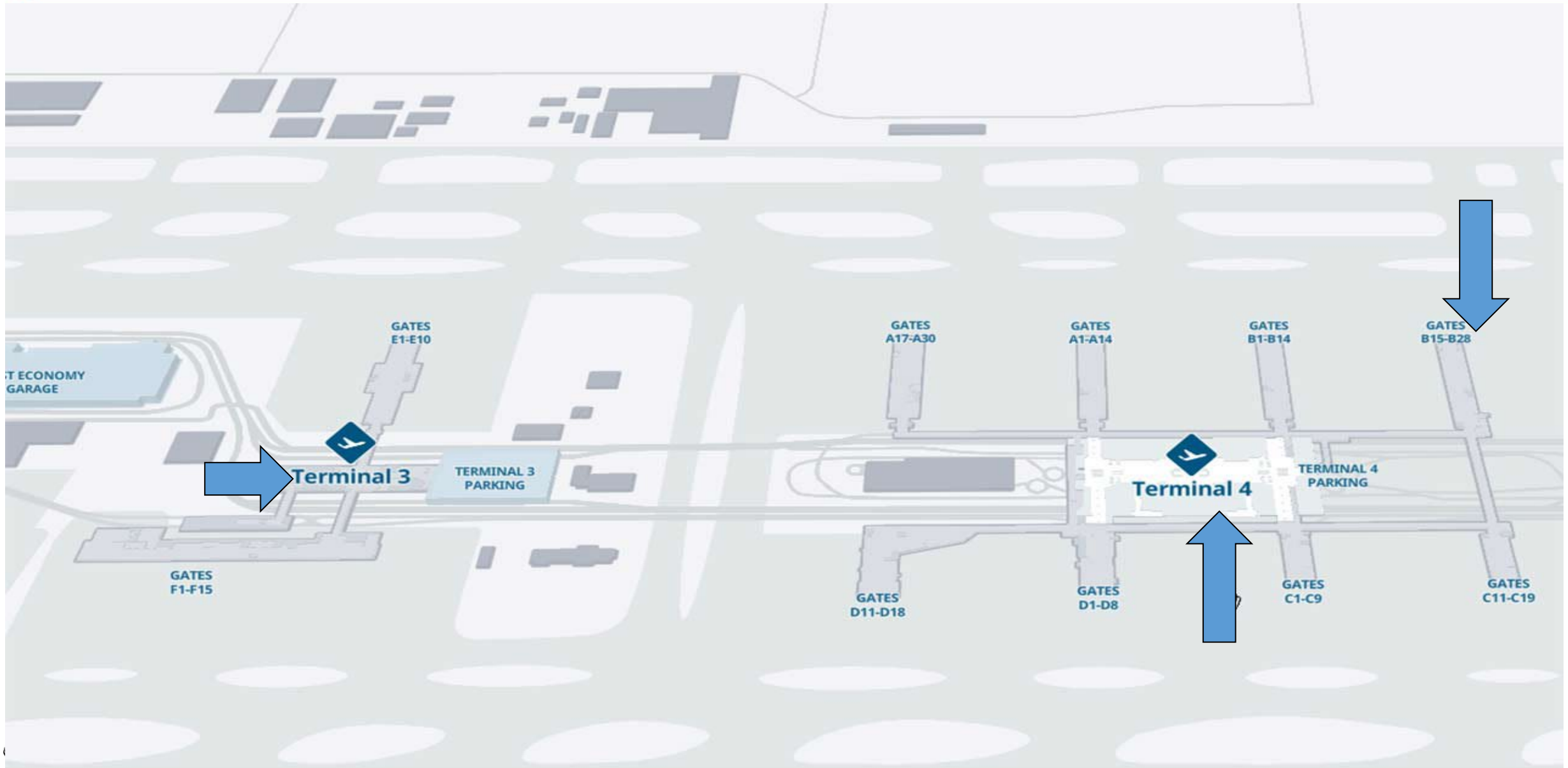



Terminal 3 – Outbound



Overview

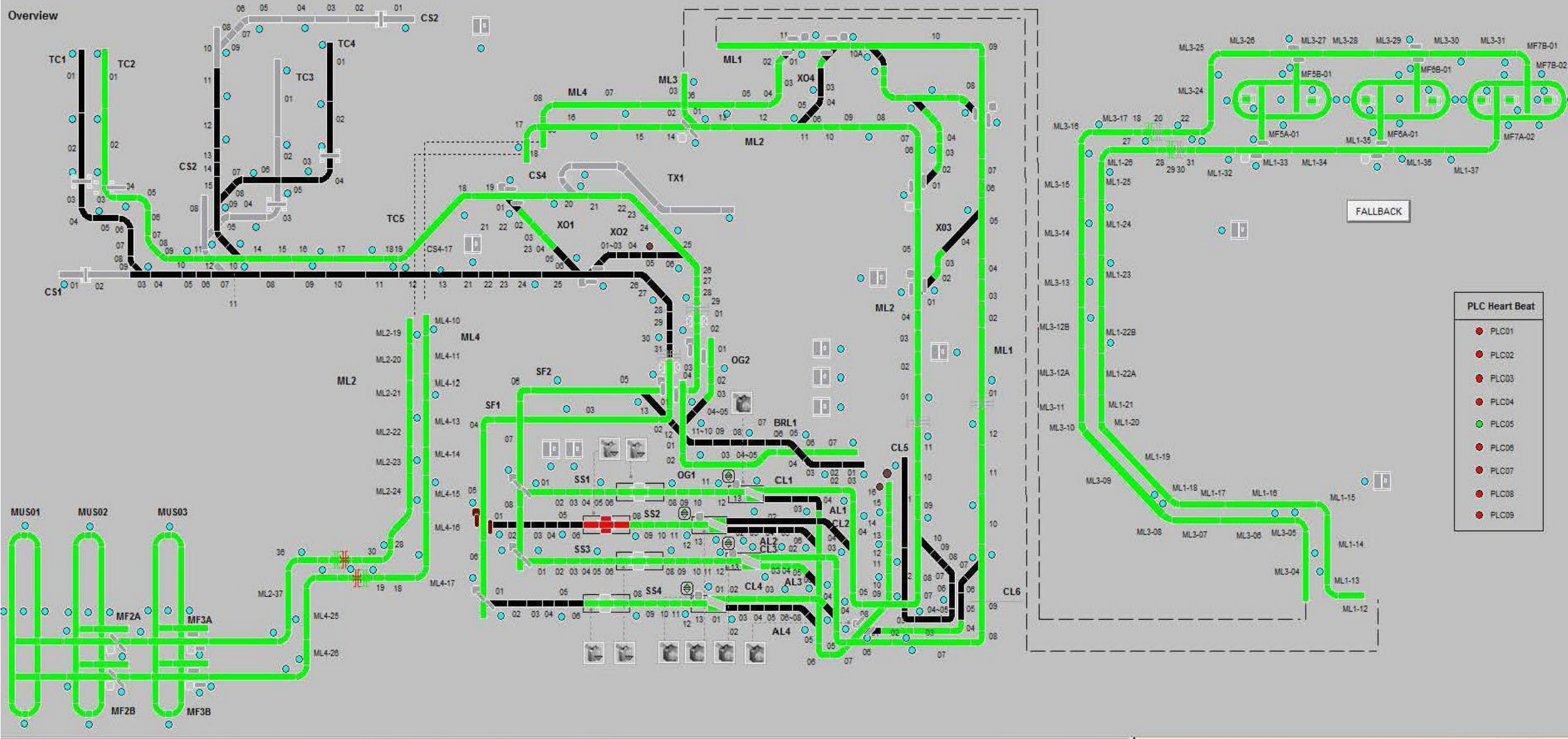



Terminal 3 – Inbound



T3 Inbound Map

IB #1

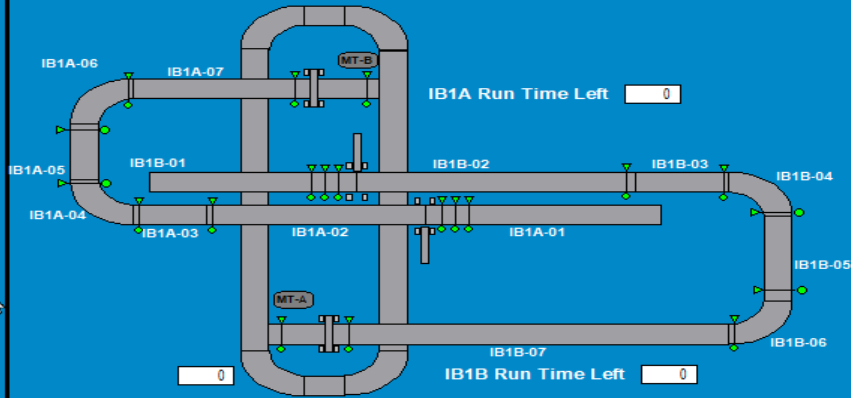

IB #2

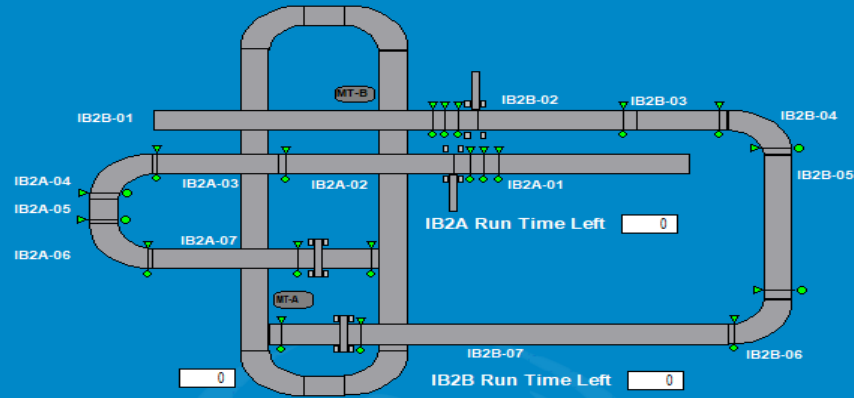

IB #3

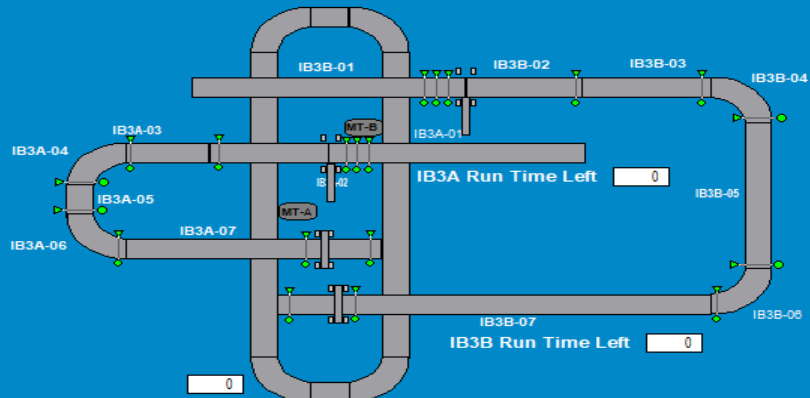

IB #4

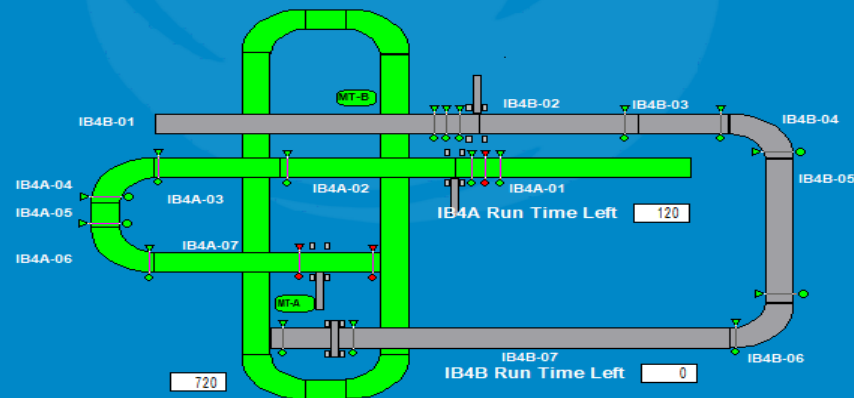

IB #5

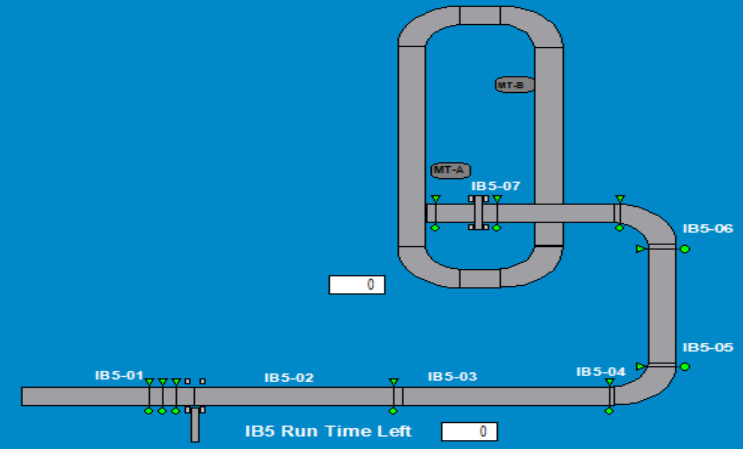

Fire Doors / Security Doors

FD / IB1A-01	Open	SD / IB1A-07	Closed
FD / IB1B-01	Open	SD / IB1B-07	Closed
FD / IB2A-01	Open	SD / IB2A-07	Closed
FD / IB2B-01	Open	SD / IB2B-07	Closed
FD / IB3A-01	Open	SD / IB3A-07	Closed
FD / IB3B-01	Open	SD / IB3B-07	Closed
FD / IB4A-01	Open	SD / IB4A-07	Open
FD / IB4B-01	Open	SD / IB4B-07	Closed
FD / IB5-01	Open	SD / IB5-07	Closed

Inbound Count Totals



Terminal 4 – Inbound

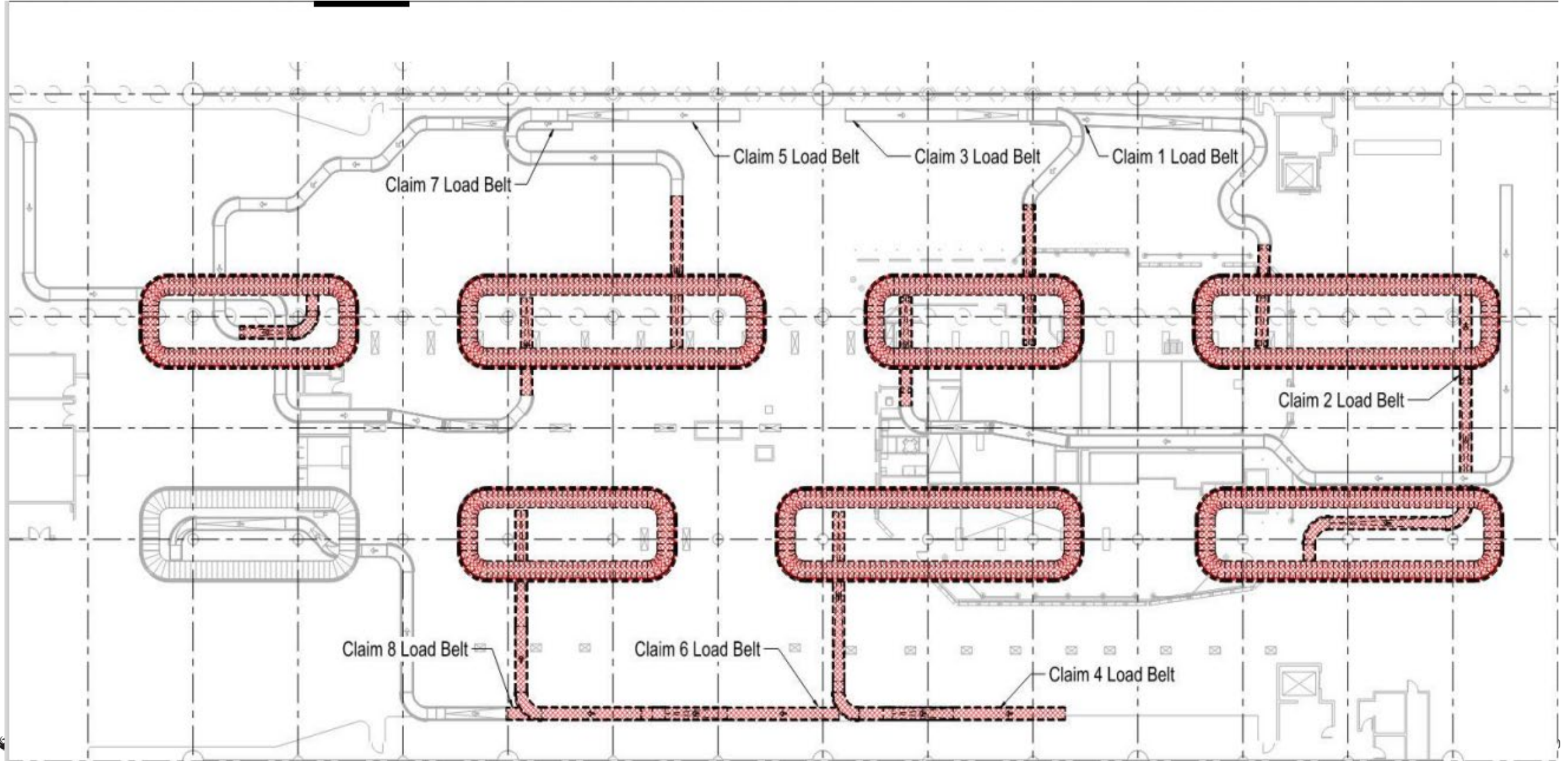



Terminal 4 International – Outbound

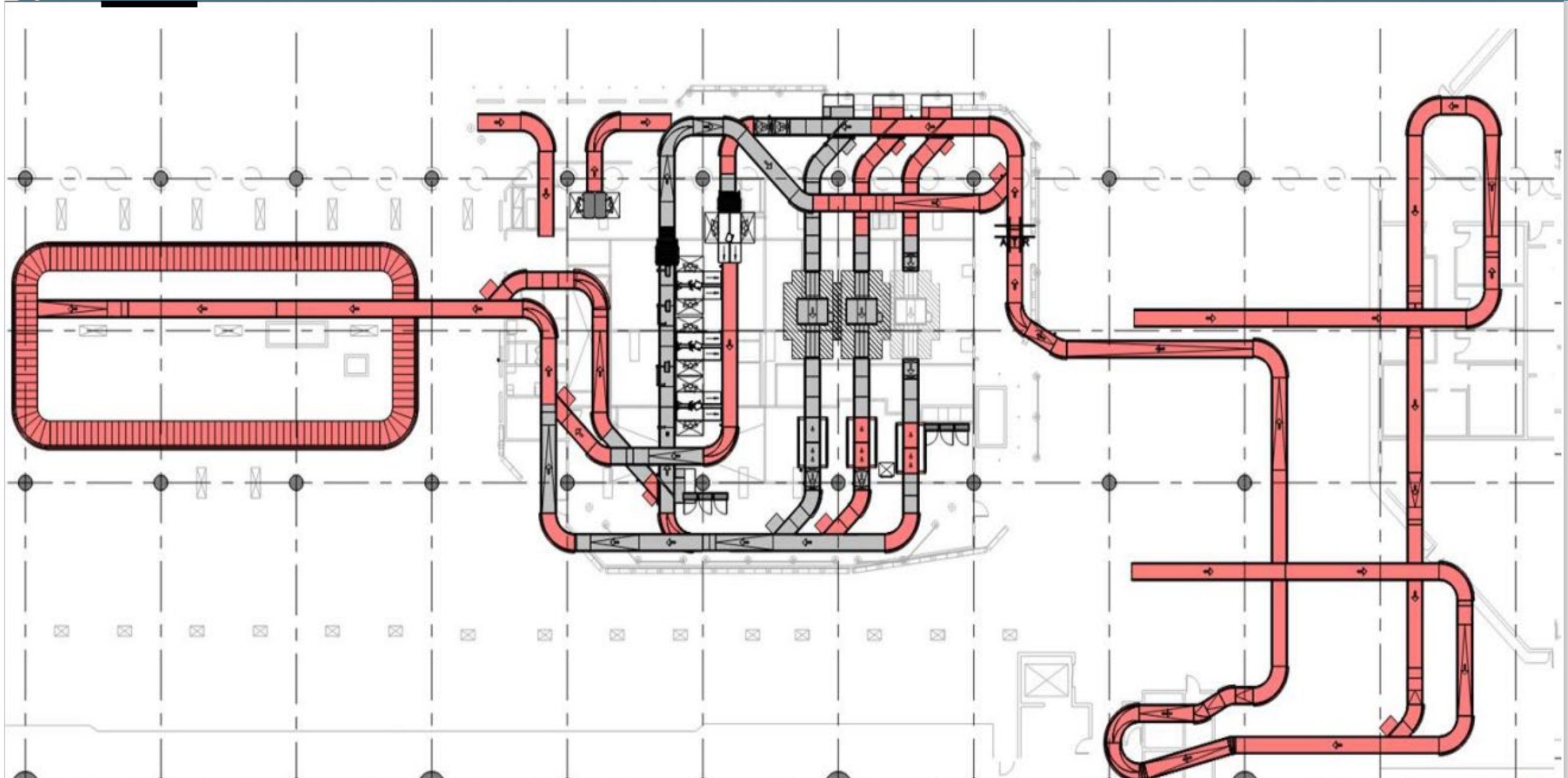



Terminal 4 International – Recheck Outbound



T4 Recheck Overview

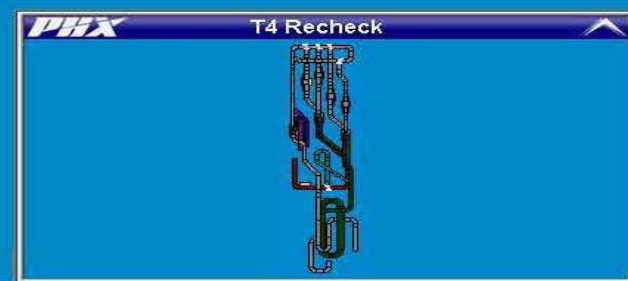
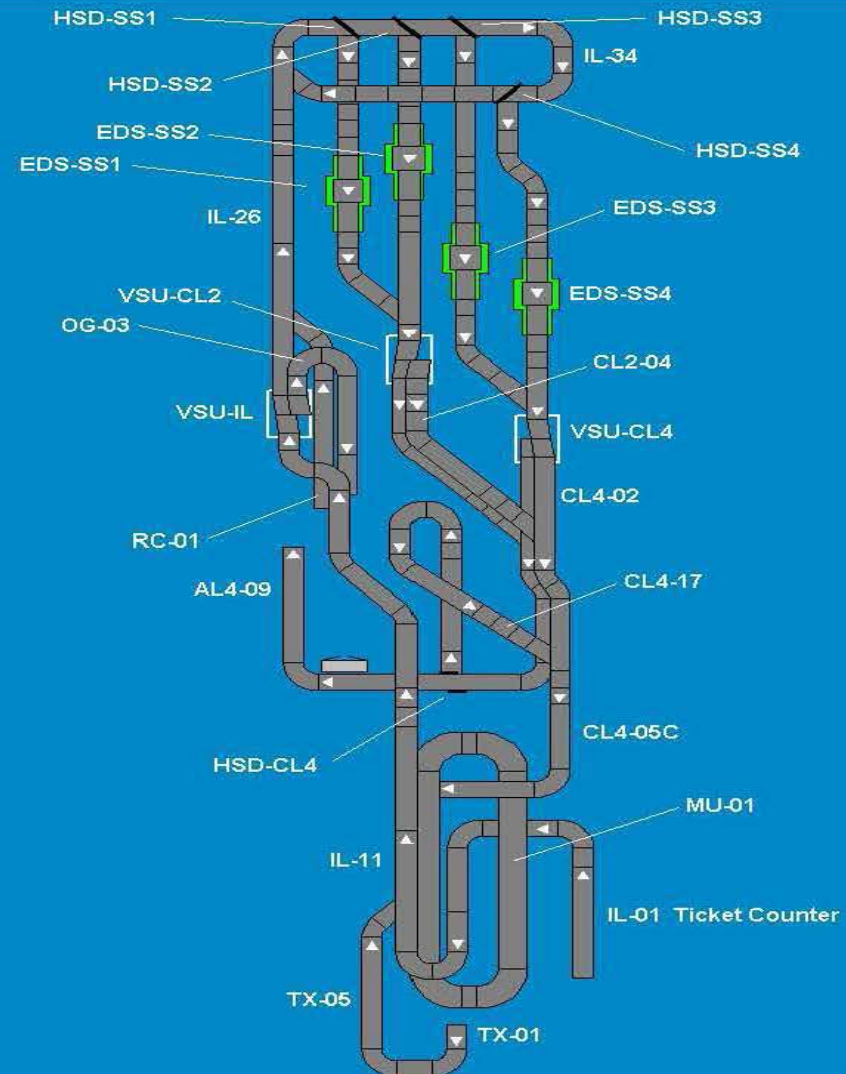



Terminal 4 International – FIS Inbound



PHOENIX SKY HARBOR
INTERNATIONAL AIRPORT

T4 Inbound IC Overview





□ **Section 3, Paragraph 3.8 – Parts and Materials (Page 25-26)**

- At the start of this contract, the City may have an inventory of parts that may be used for BHS maintenance/repair services. The City will retain ownership of these parts.
- After the City's inventory is exhausted, the Contractor will be responsible to replenish and maintain the inventory at the Contractor's cost.
- The City will pay for parts at a discount off the list price defined in **Exhibit D – Pricing Proposal** when the part has been used to complete maintenance/repair services.
- At the end of the contract term, the City will retain ownership of any of the City's original inventory that has not been used.
- At the City's discretion, may negotiate to purchase the Contractor's remaining inventory.
- Parts and/or materials must be OEM-specific unless approved in advance by the ADR.
- Recommended Critical Parts List is found in **Exhibit E**.



- ❑ Contractor will assist in the support of the BHS databases and architectural controls at Phoenix Sky Harbor International Airport.
- ❑ Provide additional services as needed to include:
 - Software and system configuration changes to PLC code
 - System modifications
 - Design and installation of new hardware and/or software



Current/Future BHS Projects



- Terminal 4 Recheck
- Terminal 4 FIS Inbound
- Terminal 4 International
- Terminal 4 North
- Terminal 4 Inbounds
- Terminal 3



**Thank You for
Attending!**

