



City of Phoenix

INVITATION FOR BID
IFB-25-0480
SIGNAGE PRODUCTS AND SERVICES

City of Phoenix
Finance Central Procurement
251 W Washington St.
8 FL
Phoenix, AZ
85003

RELEASE DATE: December 20, 2024
DEADLINE FOR QUESTIONS: January 8, 2025
RESPONSE DEADLINE: January 17, 2025, 2:00 pm

City of Phoenix
INVITATION FOR BID
IFB-25-0480
Signage Products and Services

1. Introduction	3
2. Instructions	5
3. Scope of Work	13
4. Standard Terms and Conditions.....	22
5. Special Terms and Conditions	38
6. Defense and Indemnification.....	44
7. Insurance Requirements	45
8. Submittals	48

Exhibit A – Supplemental Terms and Conditions to All Airport Agreements

Exhibit B – Design Example of Custom Signage

Exhibit C – 4’ X 8’ Signs

Exhibit D – Cradles for 4’ X 8’ Signs

Exhibit E – Notice of Posting

Exhibit F – Hearing Signs

Exhibit G – Historic Preservation Blue Historic District Sign

Exhibit H – Historic Preservation Grant Sign

Exhibit I – Historic Preservation Aluminum Plaques

Attachments (Submittal Section):

- Pricing Proposal (Attached separately as an Excel Document on <https://solicitations.phoenix.gov/> page)
- 24 Hour Emergency Contact
- Warranty
- Years in Business and References
- Costs and Payments
- Offer Page
- Conflict of Interest and Transparency

1. Introduction

1.1. Summary

The City of Phoenix is seeking Contractor(s) to provide Signage Products and Services, on an as-needed basis for Citywide departments.

1.2. Contact Information

Daniel Han

Finance Procurement Officer
251 W Washington St.
8 FL
Phoenix, AZ 85003
Email: daniel.han@phoenix.gov
Phone: [\(602\) 262-4439](tel:(602)262-4439)

Department:

Finance Central Procurement

1.3. Timeline

Schedule of Events

The City reserves the right to change dates, times, and locations, as necessary. All times are Phoenix local time. The City does not always hold a Pre-Offer Conference or Site Visit.

To request a reasonable accommodation or alternative format for any public meeting, please contact the Procurement Officer (Daniel Han) at (602) 262-4439/Voice or 711/TTY, or daniel.han@phoenix.gov, no later than two (2) weeks prior to the meeting.

Solicitation Issue Date	December 20, 2024
Pre-Offer Conference (Non-Mandatory)	December 27, 2024, 9:00am Join from the meeting link https://cityofphoenix.webex.com/cityofphoenix/j.php?MTID=m485d41f57478de2b3dc55caff7aed4a2 Join by meeting number Meeting number (access code): 2867 246 3979 Meeting password: 3ydMSDHPJ82
Written Inquiries Due Date	January 8, 2025, 2:00pm

Offer Due Date	January 17, 2025, 2:00pm Refer to Section 2.12. Submission of Offeror for instructions on how to submit an Offer.
-----------------------	--

2. Instructions

2.1. Description – Statement of Need

The City of Phoenix invites sealed offers for Signage Products and Services, including furnishment, installation, maintenance, removal, relocation, and replacement of various signage, for a five-year contract commencing on or about April 1, 2025, in accordance with the specifications and provisions contained herein or the “Effective Date” which is upon award by City Council, conditioned upon signature and recording by the City Clerk’s department, as required by the Phoenix City Code, whichever is later.

This solicitation is available through Arizona Relay Service 7-1-1. Please call TTY 800-367-8939 for assistance.

Notwithstanding the foregoing, this Agreement will terminate upon the earliest occurrence: by reaching the end of the term including any extensions exercised, or termination pursuant to the provisions of this Agreement.

2.2. City's Vendor Self-Registration and Notification

Vendors must be registered in the City’s procurePHX Self-Registration System at <https://www.phoenix.gov/procure> to respond to solicitations and access procurement information. The City may, at its sole discretion, reject any offer from an Offeror who has not registered.

2.3. Preparation of Offer

All forms provided in Submittal Section must be completed and submitted with the Offer. The signed and completed Conflict of Interest and Transparency form must be included or your Offer may be deemed non-responsive.

It is permissible to copy Submittal forms if necessary. Erasures, interlineations, or other modifications of the Offer must be initialed in original ink by the authorized person signing the Offer. No offer will be altered, amended or withdrawn after the specified offer due date and time. The City is not responsible for Offeror’s errors or omissions.

All time periods stated as a number of days will be calendar days.

It is the responsibility of all Offerors to examine the entire solicitation and seek clarification of any requirement that may not be clear and to check all responses for accuracy before submitting an offer. Negligence in preparing an offer confers no right of withdrawal after due date and time. Offerors are strongly encouraged to:

- A. Consider applicable laws and/or economic conditions that may affect cost, progress, performance, or furnishing of the products or services.
- B. Study and carefully correlate Offeror’s knowledge and observations with the solicitation and other related data.
- C. Promptly notify the City of all conflicts, errors, ambiguities, or discrepancies that Offeror has discovered in or between the solicitation and other related documents.

- D. The City does not reimburse the cost of developing, presenting or providing any response to this solicitation. Offers submitted for consideration should be prepared simply and economically, providing adequate information in a straightforward and concise manner. The Offeror is responsible for all costs incurred in responding to this solicitation. All materials and documents submitted in response to this solicitation become the property of the City and will not be returned.
- E. Offerors are reminded that the specifications stated in the solicitation are the minimum level required and that offers submitted must be for products or services that meet or exceed the minimum level of all features specifically listed in this solicitation. Offers offering less than any minimum specifications or criteria specified are not responsive and should not be submitted.
- F. Offer responses submitted for products considered by the seller to be acceptable alternates to the brand names or manufacturer's catalog references specified herein must be submitted with technical literature and/or detailed product brochures for the City's use to evaluate the products offered. Offers submitted without this product information may be considered as non-responsive and rejected. The City will be the sole judge as to the acceptability of alternate products offered.
- G. Prices will be submitted on a per unit basis by line item, when applicable. In the event of a disparity between the unit price and extended price, the unit price will prevail unless obviously in error.

2.4. Fixed Offer Price Period

All offers shall be firm and fixed for a period of 180 calendar days from the solicitation opening date.

2.5. Obtaining a Copy of the Solicitation and Addenda

Interested Offerors may download the complete solicitation and addenda from <https://solicitations.phoenix.gov/>. Any interested Offerors without internet access may obtain this solicitation by calling the Procurement Officer or picking up a copy during regular business hours at the City of Phoenix, Finance Department, Central Procurement Division, 251 W Washington Street, 8th Floor, Phoenix, AZ. It is the Offeror's responsibility to check the website, read the entire solicitation, and verify all required information is submitted with their Offer.

2.6. Exceptions

Offeror must not take any exceptions to any terms, conditions or material requirements of this solicitation. Offers submitted with exceptions may be deemed non-responsive and disqualified from further consideration in the City's sole discretion. Offerors must conform to all the requirements specified in the solicitation. The City encourages Offerors to send inquiries to the Procurement Officer rather than including exceptions in their Offer.

2.7. Inquiries

All questions that arise relating to this solicitation should be directed via email to the Procurement Officer and must be received by the due date indicated in the Schedule of Events. The City will not consider questions received after the deadline.

No informal contact initiated by Offerors on the proposed service will be allowed with members of City's staff from date of distribution of this solicitation until after city council awards the contract. All questions concerning or issues related to this solicitation must be presented in writing.

The Procurement Officer will answer written inquiries in an addendum and publish any addendums on the Procurement Website.

2.8. Addenda

The City of Phoenix will not be responsible for any oral instructions made by any employees or officers of the City of Phoenix regarding this solicitation. Any changes will be in the form of an addendum. The Offeror must acknowledge receipt of any/all addenda by signing and returning the document with the Offer submittal.

2.9. Business in Arizona

The City will not enter contracts with Offerors (or any company(ies)) not granted authority to transact business, or not in good standing, in the state of Arizona by the Arizona Corporation Commission, unless the Offeror asserts a statutory exception prior to entering a contract with the City.

2.10. Licenses

If required by law for the operation of the business or work related to this Offer, Offeror must possess all valid certifications and/or licenses as required by federal, state or local laws at the time of submittal.

2.11. Certifications

By signature in the Offer section of the Offer and Acceptance page(s), Offeror certifies:

- The submission of the Offer did not involve collusion or other anti-competitive practices.
- The Offeror must not discriminate against any employee, or applicant for employment in violation of Federal or State Law.
- The Offeror has not given, offered to give, nor intends to give at any time hereafter, any economic opportunity, future employment, gift, loan, gratuity, special discount, trip, favor, or service to a public servant in connection with the submitted Offer.

2.12. Submission of Offer

Offers must be in possession of the Department on or prior to the exact time and date indicated in the Schedule of Events. Late offers will not be considered. The prevailing clock will be the City Department's clock.

Offers must be submitted electronically by email to procurement@phoenix.gov and the following information should be noted in the email:

- A. Offeror's Name
- B. Offeror's Address (as shown on the Certification Page)
- C. Solicitation Number
- D. Solicitation Title
- E. Offer Opening Date
- F. Due to file size limitations for electronic transmission (for sending or receiving), Offers sent by email may need to be sent in parts with multiple emails. It is the responsibility of the Offeror to ensure that the Offer (including all parts if sent in multiple emails) is timely and to confirm that there are no technical reasons that any offer submitted electronically may be delayed. The date and time on the email(s) as received/stamped by the City's inbox will provide proof of submission and verification whether the Offer was received on or prior to the exact time and date indicated in the Schedule of Events.
- G. Any original documents (such as bonds, guaranties, powers of attorney), if required by the solicitation, must be separately delivered to and received by the City on or prior to the exact time and date indicated in the Schedule of Events, with a clear indication of the Offer for which it is attributed.

2.13. Withdrawal of Offer

At any time prior to the solicitation due date and time, an Offeror (or designated representative) may withdraw the Offer by submitting a request in writing and signed by a duly authorized representative. If Offeror withdraws the Offer electronically by email to the Procurement Officer, the request to withdraw must be in the form of a letter attached to the email that includes either an image of the duly authorized representative's signature or an electronic signature from a verifiable source, such as Adobe Sign, DocuSign or a similar verifiable software program.

2.14. Offer Results

Offers will be opened on the offer due date, time and location indicated in the Schedule of Events, at which time the name of each Offeror, and the prices may be read. Offers and other information received in response to the solicitation will be shown only to authorized City personnel having a legitimate interest in them or persons assisting the City in the evaluation. Offers are not available for public inspection until after the City has posted the award recommendation on the City's website.

The City will post a preliminary offer tabulation on the City's website, <https://solicitations.phoenix.gov/Awards> within five business days of the offer opening. The City will post the information on the preliminary tabulation as it was read during the offer opening. The City makes no guarantee as to the accuracy of any information on the preliminary tabulation. Once the City has evaluated the offers, the City will post an award recommendation on the website. By signing and submitting its Offer, each Offeror agrees that this posting of the award recommendation to the City's website effectively serves as the Offeror's receipt of that notice of

award recommendation. The City has no obligation to provide any further notification to unsuccessful Offerors.

2.15. Pre-Award Qualifications

Offeror must have been in operation a minimum of three years. The Offeror's normal business activity during the past three years will have been for providing the goods or services in this solicitation.

Upon notification of an intent to award, the Offeror will have ten calendar days to submit a complete certificate of insurance in the minimum amounts and the coverages as required in the Insurance Requirements of this agreement. Insurance requirements are non-negotiable.

2.16. Award of Contract

Unless otherwise indicated, award(s) will be made to the most responsive, responsible Offeror(s) who are regularly established in the service, or providing the goods, contained in this solicitation and who have demonstrated the ability to perform in an acceptable manner.

- A. Factors that may be considered by the City include:
 1. Technical capability of the Offeror to accomplish the scope of work required in the Solicitation. This may include performance history on past and current government or industrial contracts; and,
 2. Demonstrated availability of the necessary manpower (both supervisory and operational personnel) and necessary equipment to accomplish the scope of work in the Solicitation; and,
 3. Safety record; and,
 4. Offeror history of complaints and termination for convenience or cause.
- B. Notwithstanding any other provision of this solicitation, the City reserves the right to: (1) waive any immaterial defect or informality; or (2) reject any or all offers or portions thereof; or (3) reissue a solicitation.
- C. A response to a solicitation is an offer to contract with the City based upon the terms, conditions, and specifications contained in the City's solicitation. Offers do not become contracts until they are executed by the Chief Procurement Officer or Department Director. A contract has its inception in the award, eliminating a formal signing of a separate contract. For that reason, all of the terms, conditions and specifications of the procurement contract are contained in the solicitation, and in any addendum or contract amendment.

2.17. Solicitation Transparency Policy

Commencing on the date and time a solicitation is published, potential or actual Offerors or respondents (including their representatives) shall only discuss matters associated with the solicitation with the Mayor, any members of City Council, the City Manager, any Deputy City Manager, or any department director directly associated with the solicitation (including in each case their assigned staff, except for the designated Procurement Officer) at a public meeting,

posted under Arizona Statutes, until the resulting contract(s) are awarded to all offers or responses are rejected and the solicitation is cancelled without any announcement by the Procurement Officer of the City's intent to reissue the same or similar solicitation.

As long as the solicitation is not discussed, Offerors may continue to conduct business with the City and discuss business that is unrelated to the solicitation with the City staff. Offerors may not discuss the solicitation with any City employees or evaluation panel members.

Offerors may discuss their proposal or the solicitation with the Mayor or one or more members of the Phoenix City Council, provided such meetings are scheduled through the Procurement Officer, and are posted as open meetings with the City Clerk at least 24 hours prior to the scheduled meetings. The City Clerk will be responsible for posting the meetings. The posted notice shall identify the participants and the subject matter, as well as invite the public to participate.

With respect to the selection of the successful Offerors, the City Manager and/or City Manager's Office will continue the past practice of exerting no undue influence on the process. In all solicitations of bids and proposals, any direction on the selection from the City Manager and/or City Manager's Office and Department Head (or representative) to the proposal review panel or selecting authority must be provided in writing to all prospective Offerors.

This policy is intended to create a level playing field for all Offerors, assure that contracts are awarded in public, and protect the integrity of the selection process. OFFERORS THAT VIOLATE THIS POLICY SHALL BE DISQUALIFIED. After official Notice is received by the City for disqualification, the Offeror may follow the Protest process, unless the Solicitation is cancelled without notice of intent to re-issue.

"To discuss" means any contact by the Offeror, regardless of whether the City responds to the contact. Offerors that violate this policy will be disqualified until the resulting contract(s) are awarded, or all offers or responses are rejected and the solicitation is cancelled without any announcement by the Procurement Officer of the City's intent to reissue the same or a similar solicitation. The City interprets the policy as continuing through a cancellation of a solicitation until Council award of the contract, as long as the City cancels with a statement that the City will rebid the solicitation.

2.18. Protest Process

Offeror may protest the contents of a solicitation no later than seven days before the solicitation deadline when the protest is based on an apparent alleged mistake, impropriety or defect in the solicitation. Protests filed regarding the solicitation may be addressed by an amendment to the solicitation or denied by the City. If denied, the opening and award will proceed unless the City determines that it is in the City's best interests to set new deadlines, amend the solicitation, cancel or re-bid.

Therefore, unless otherwise notified by a formal amendment, the Protester must adhere to all solicitation dates and deadlines, including timely filing of an offer, regardless of filing a protest.

Offeror may protest an adverse determination issued by the City regarding responsibility and responsiveness, within seven days of the date the Offeror was notified of the adverse determination.

Offeror may protest an award recommendation if the Offeror can establish that it had a substantial chance of being awarded the contract and will be harmed by the recommended award. The City will post recommendations on the City's website to award the contract(s) to an Offeror(s). Offeror must submit award protests within seven days after the posting of the award recommendation, with exceptions only for good cause shown, within the City's full and final discretion.

All protests will be in writing, filed with the Procurement Officer identified in the solicitation and include the following:

- Identification of the solicitation number;
- The name, address and telephone number of the protester;
- A detailed statement describing the legal and factual grounds for the protest, including copies of relevant documents;
- The form of relief requested; and
- The signature of the protester or its authorized representative.

The Procurement Officer will render a written decision within a reasonable period after the protest is filed. The City will not request City Council authorization to award the contract until the protest process is complete. All protests and appeals must be submitted in accordance with the City's Procurement Code, (Phoenix City Code, Ch. 43) and any protests or appeals not submitted within the time requirements will not be considered. Protests must be filed with the Procurement Officer.

2.19. Public Record

All Offers submitted in response to this solicitation will become the property of the City and become a matter of public record available for review pursuant to Arizona State law. If an Offeror believes that a specific section of its Offer response is confidential, the Offeror will isolate the pages marked confidential in a specific and clearly labeled section of its Offer response. An Offeror may request specific information contained within its Offer is treated by the Procurement Officer as confidential provided the Offeror clearly labels the information "confidential." To the extent necessary for the evaluation process, information marked as "confidential" will not be treated as confidential. Once the procurement file becomes available for public inspection, the Procurement Officer will not make any information identified by the Offerors as "confidential" available to the public unless necessary to support the evaluation process or if specifically requested in accordance with applicable public records law. When a public records request for such information is received, the Procurement Officer will notify the Offeror in writing of any request to view any portion of its Offer marked "confidential." The Offeror will have the time set forth in the notice to obtain a court order enjoining such disclosure. If the Offeror does not provide the Procurement Officer with a court order enjoining release of the information during the designated time, the Procurement Officer will make the information requested available for inspection.

2.20. Late Offers

Late Offers must be rejected, except for good cause. If a late Offer is submitted, the Department will document the date and time of the submittal of the late Offer, keep the Offer and notify the Offeror that its Offer was disqualified for being a late Offer.

2.21. Right to Disqualify

The City reserves the right to disqualify any Offeror who fails to provide information or data requested or who provides materially inaccurate or misleading information or data. The City further reserves the right to disqualify any Offeror on the basis of any real or apparent conflict of interest that is disclosed by the Offer submitted or any other data or information available to the City. This disqualification is at the sole discretion of the City. By submission of a solicitation response, the Offeror waives any right to object now or at any future time, before any agency or body including, but not limited to, the City Council of the City or any court as to the exercise by the City of such right to disqualify or as to any disqualification by reason of real or apparent conflict of interest determined by the City. The City reserves the right to replace the disqualified Offeror.

2.22. Contract Award

In accordance with the City of Phoenix Code, Chapter 43, Section 43-12, Competitive Sealed Bidding, award(s) shall be made to the lowest responsible and responsive offeror(s) whose offer conforms in all material respects to the requirements set forth in this solicitation. The City reserves the right to award a contract by individual line items, by group, all or none, or any other combination most advantageous to the City. The City reserves the right to multiple award.

2.23. Determining Responsiveness and Responsibility

Offers will be reviewed for documentation of any required minimum qualifications, and completeness and compliance with the solicitation requirements. The City reserves sole discretion to determine responsiveness and responsibility.

Responsiveness: Nonresponsive Offers will not be considered in the evaluation process. The solicitation states criteria that determine responsiveness, and the solicitation includes terms and conditions that if included or excluded from Offers will render an Offer nonresponsive.

Responsibility: To obtain true economy, the City must conduct solicitations to minimize the possibility of a subsequent default by the Offeror, late deliveries, or other unsatisfactory performance that may result in additional administrative costs. It is important that the Offeror be a responsible Offeror. Responsibility includes the Offeror's integrity, skill, capacity, experience, and facilities for conducting the work to be performed.

2.24. Equal Low Offer

Contract award will be made by putting the names of the tied Offerors in a cup for a blind drawing limited to those bidders with tied Offers. If time permits, the Offerors involved will be given an opportunity to attend the drawing. The drawing will be witnessed by at least three persons, and the contract file will contain the names and addresses of the witnesses.

3. Scope of Work

3.1. Background

The City requires furnishment, installation, maintenance, removal, relocation, and replacement of various signage, including but not limited to:

- A. Zoning and general hearing signs
- B. ADA-compliant signage
- C. Room, and directional signage
- D. Indoor and outdoor building signage
- E. Letters of all types
- F. Logos
- G. Plaques
- H. Banners
- I. Evacuation and orientation maps
- J. Custom signs
- K. Outdoor marquees
- L. Changeable message centers
- M. Various signage mounts and poles
- N. Other signage as-needed

3.2. Contractor's Requirements

Contractor shall:

- A. Provide all equipment and materials needed to complete services and be responsible for transporting Contractor's equipment to and from the job site.
- B. Clean and remove from the job site all debris, materials, and equipment associated with the work performed.
- C. Obtain locator services to perform underground utility locations prior to installation of exterior signs that require posthole or foundation excavation.
- D. Follow all City of Phoenix, Zoning Ordinance requirements in Section 705 Signs (<https://phoenix.municipal.codes/ZO/705>) as applicable.
 - 1. Contractor is responsible for obtaining and paying for permits or fees for all signage.
- E. Coordinate and schedule services with individual City Department's Representatives.

3.3. Sign Requirements

- A. Signs shall be clearly legible and placed at a designated location on the City site.
- B. Materials shall be new stock, free from defects, or imperfections in strength, durability, and appearance.
- C. Signage shall meet the following requirements as applicable:
 - 1. ADA signage shall meet the current applicable Americans with Disability Act (ADA) standards.
- D. Custom Signs
 - 1. Custom signage may be requested, which includes incorporation of City supplied graphics or artwork designs, such as designs shown in the Exhibit B.
 - a. Contractor shall provide shop drawings to City Department's Representative for an approval before an order is processed.
- E. Samples
 - 1. If requested by City, samples shall be provided at no extra charge before an order is processed, to ensure confirmation with size and material quality.

3.4. Installation of Signs

Contractor shall:

- A. Install and present for inspection all signs, products, and deliverables in a complete and ready-for-use condition with all components functioning, cleaned and tested.
- B. Erect signs for structural quality while on the subject property until final disposition of the Zoning and General Hearing case, if requested.
- C. Obtain utility clearance, if applicable, prior to installation.
- D. Utilize mounting methods as applicable. The mounting materials shall not corrode or damage sign materials or mounting surface. Examples of mounting methods include, but not limited to:
 - 1. Concealed fasteners
 - 2. Hook-and-loop tape
 - 3. Double-sided vinyl tape
 - 4. Magnetic tape
 - 5. Anchors and inserts
 - 6. Outdoor sign anchoring requiring concrete or special footing
 - 7. Stakes

- E. Follow all City Department Representative's instructions on various requirements such as:
 - 1. How deep the mount has to be buried.
 - 2. The type of mount that shall be utilized.
 - 3. Orientation of the sign posting.
 - 4. Location of the installation per written instructions and/or as indicated by a posting map provided by the City Department Representative at time of order.
- F. Ensure installed signs are adequately constructed to withstand field conditions. Contractor is responsible for the structural quality of the sign once installed for the duration of the posted period.
- G. Provide Proof of Installation
 - 1. Contractor must provide proof of installation by posting deadline, for all Zoning and General Hearing signage, including a digitally produced photograph of the installed sign with each location described along with each face labeled, and a completed Notice of Posting (Exhibit D)
 - a. The photo(s) and posting affidavit shall be sent by email to an email address to be provided by the requested City Department Representative.
 - 2. For other signage requests, proof of installation will be as requested by a City Department Representative.

3.5. Removal of Signs

- A. Upon request, the Contractor shall have 7 calendar days upon receipt of order from requested Department to remove signage.
- B. Contractor shall collect all installation materials and recycle materials into the manufacture of new signs whenever possible.

3.6. Relocation of Signs

- A. Signs may be requested to be moved at the discretion of the City Department Representative.
- B. Any signage not installed per City instructions shall be reinstalled at no additional cost to the City.

3.7. Repair or Replacement of Signs

- A. Signage shall be repaired or replaced at the discretion of the City.
- B. The costs of Signage requiring repair or replacement shall be paid by the City, unless the sign is covered by a warranty.

3.8. Text Revisions of Signs

- A. A text revision is defined as a change to signage text after the Contractor rendering is approved by the City Department Representative for installation.
- B. Text revisions either before or after installation, will be sent to Contractor via e-mail and may be applied as either a placard or as an entire new sign face, but must be invoiced by Contractor as a text revision.

3.9. Required Timeframes

Contractor shall adhere to the following completion timeframes:

- A. Have 3 business days to complete the order which includes manufacturing, installation, replacement, and/or relocation of all signs.
 - 1. Any signage that requires more than 3 business days shall be reviewed and approved by City Department Representative.
 - 2. For the following Zoning and General Hearing Signage and Historic Preservation Signage, the Contractor shall follow the following required timeframes:
 - a. Coroplast Signs - 3 Business Days
 - b. 4X8 Signs - 7 Business Days
 - c. Historic Plaques and Historic Signs - 30 Business Days
- B. Have 7 calendar days to fulfill orders for sign removal after the request is placed by City Department Representative.

3.10. Rental Equipment

The Contractor shall:

- A. Identify if rental equipment is required for building signage, such as scaffolding, lifts, and other heavy rental equipment.
- B. Obtain prior approval from the City Department Representative before securing rental equipment.
- C. Be reimbursed at the actual expense of the Contractor, without any markup, overhead, and profit. The Contractor shall provide copy of equipment rental invoice(s) to the City Department's Representative and attach invoice(s) to the Contractor's main invoice, otherwise, payment will be withheld. The City will not accept any invoices that have been altered in any manner.

3.11. Product Specification - Group 1: All Signage

The products listed below and in the Pricing Proposal will be purchased on an-as need basis. Any items not listed specifically below or in the Pricing Proposal, will be purchased through a fixed discount list, or manufacturer's list pricing.

- A. Nameplates with lettering
 - 1. 6" X 6" name plate
 - a. White frosted finish
 - b. Black opaque vinyl lettering spelling out names
 - c. Font Color: Black Matte/Opaque
 - 2. 2" X 8" name plate
 - a. Silver
 - b. Metal
- B. National Fire Protection Association (NFPA) signs for various hazards such as diesel gas, natural gas, sodium hypochlorite, etc
 - 1. Blue, Red, Yellow, White with numbers and lettering.
 - 2. Various sizes:
 - a. 12" X 12"
 - b. 18" X 18"
 - 3. Adhesive backing to be placed on plastic tanks.
- C. Aluminum .080 panels with lettering or custom designs
 - 1. Various sizes:
 - a. 12" X 18"
 - b. 18" X 12"
 - c. 24" X 18"
 - d. 24" X 24"
 - e. 36" X 12"
 - f. 36" X 24"
 - g. 48" X 30"
 - 2. Various backgrounds:
 - a. Engineer grade reflective vinyl

- b. Diamond grade reflective vinyl
3. Various colors
4. Various rounded corners:
 - a. 0.5" to 1.5" rounded corners
5. Sign attached to pole or chain link fence.
6. If applicable, be ADA compliant signage.

3.12. Product Specification - Group 2: Zoning and General Hearing Signage and Historic Preservation Signage

A. 4' X 8' Signs

1. A single sheet of 5-ply laminated plywood, ½" minimum thickness with case information on one side (or both sides for a dual-sided posting).
2. Pre-printed heavy duty 10 mm white coroplast with case information on one side.
3. A single sided sign will be defined as a single sheet of plywood or coroplast mounted with case information on one side.
4. A double-sided sign defined as a single sheet of plywood with case information clearly visible on both sides or 2 sheets of coroplast with case information clearly visible on one side of each sheet.
5. The front, back and all edges of the plywood signs shall be painted with 2 coats of white exterior acrylic enamel paint. Reused sign material and posts must not exhibit "ghost" images when installed.
6. Black lettering sizes and fonts will match proportionally with characters on a template that will accompany orders (Exhibit C). Duplicated renderings from the contractor must first be approved by a Planning and Development Department representative prior to installation.
7. Sign faces shall be mounted with either 2 - 4" x 4" x 10' painted (white) wood posts or wood cradles painted (white) provided by the contractor (see Exhibit C for sample sign templates and Exhibit D for sample cradle specifications).
8. All mounting posts and hardware to be provided by the contractor.
9. Graphics may be required per special case and will be denoted in sign face template provided by City Department's Representative in a separate PDF file for image clarity.

B. Cradles

1. Alternative installation method for Zoning and General Hearing Signage to be employed whenever site conditions make ground penetration:
 - a. **Prohibited** instances such as archeological or burial sites.

- b. **Unsafe** instances such as absence of readily available information from Blue Stake for underground utilities.
 - c. **Destructive** instances such as solid surface posting surfaces such as concrete or other paved material, and finished surfaces such as pavers or finished stone areas.
 2. Two types of Cradles are shown as examples in the Exhibit D.
 - a. Cradle 1 is comprised of of 4-4" x 4" X 8' wooden posts (2 upright posts and 2 skids) all sides painted white, with appropriate bracing (painted white). Cradle 1 is used primarily with 4' X 8' plywood or similar material.
 - b. Cradle 2 is comprised of 2-4" X 4" X 8' wooden posts (2 upright posts) and 4-2" X 4" X 8' wooden studs. (4 skids) all sides painted white, with appropriate bracing (painted white). Cradle 2 is used primarily with 4' X 8' White 10 Mil Coroplast material.
- C. Coroplast Signs
 1. Preprinted 24" x 24" Coroplast signs for hearing notification purposes.
 2. All Coroplast materials will be heavy duty 4mm white Coroplast cut to no smaller than 24" x 24". Preprinting on each sign will be in accordance with the approved template sent by a City Department Representative.
 3. All Coroplast templates and signs are one color (black) printed on a white background.
 4. Flutes must be aligned to the vertical.
 5. If requested, samples shall be delivered for each order to ensure conformation with size and material quality before each order is processed.
 6. Order quantities will be in multiples of 50, with 50 signs of either template as a minimum.
- D. Heavy Duty "H" Stakes
 1. "U"-top, 10" X 30" with 5 1/2" wide 1/4" diameter base.
- E. Crack and Peel Paper
 1. 60#, white, semi-gloss, permanent adhesive, exact cut to 11" X 17" crack peel paper.
- F. Blank white Coroplast Material
 1. Pre-cut white Coroplast is required in the following sizes:
 - a. 22" X 34"
 - b. 34" X 44"
- G. Historic Preservation Blue Historic District Signs

1. Aluminum Sign Blanks
 - a. 8" X 24" .063-gauge aluminum
 - b. 5052-H38 or better aluminum
 - c. Golden yellow alodine coated aluminum finish
 - d. Shear Tolerance 1/16" +-
 - e. Corners rounded to a 1-1/8" radius.
 - f. Rivet at each corner to make back to back sets ready for sign facing attachment.
 - g. Sign Face Material
 - i. 3M 4090 DG3 GR Std/Flour Sheeting
 - ii. 3M 1175C blue EC Film
 - iii. 3M 1160 Clear POF
2. Metro-Wing Style Bracket
 - a. See Exhibit F
3. Fabricated and installed as shown in Exhibit G.
 - a. When installing on a pole with an existing Stop Sign, the Contractor shall install the Historic District Identification Sign using metro-wing style bracket perpendicular to the back of the Stop Sign and not visible protruding on any side.
 - b. When installing on a light pole, the Contractor shall install the Historic District Sign using a metro-wing style bracket.
 - c. Old hardware and existing Historic District Signs removed from existing locations for installation of new signs and hardware must be returned to the City Department's Representative.
4. Assembly
 - a. Sign blanks must be assembled back-to-back and riveted prior to attachment of scotchlite sign facing.
 - b. Finished scotchlite sign facing to be bonded to assembled signs, ready for installation .
- H. Historic Preservation Grant Signs
 1. Coroplast – Preprinted 24" x 24" Coroplast signs for historic preservation grant purposes – Installed by property owner (Exhibit H).
- I. Historic Preservation Aluminum Plaques
 1. 12"w X 8"h Maximum Dimensions

2. Minimum Thickness 3/16"
3. Custom Shape
4. Raised Copy IF CAST
5. Single Line Border 3/16" wide
6. Black Semi-Gloss (Satin) with sand finish
7. Minimum of four (4) Blind Mount-Standard Studs
8. Install Historic Preservation aluminum plaques as shown in Exhibit I.

3.13. Pricing

- A. All pricing quoted by Contractor shall be consistent with the contract pricing provided in the Pricing Proposal.
- B. Unless otherwise stated in the Agreement or stated in the Pricing Proposal, all other costs or fees such as travel fees, overhead costs, and other ancillary fees associated with providing the products and services shall not be charged. All such fees shall be incorporated into the unit price as shown in the Pricing Proposal.

3.14. Business Hours and Holidays

- A. Regular business hours shall be defined as 6 AM to 6:00 PM.
- B. After business hours shall be defined as 6:01 PM to 5:59 AM.
- C. For the purposes of this contract, observed holidays can be found here:
<https://www.phoenix.gov/calendar/holidays>

4. Standard Terms and Conditions

4.1. Definition of Key Words Used in the Solicitation

Shall, Will, Must: Indicates a mandatory requirement. Failure to meet these mandatory requirements may result in the rejection of Offer as non-responsive.

Should: Indicates something that is recommended but not mandatory. If the Offeror fails to provide recommended information, the City may, at its sole option, ask the Offeror to provide the information or evaluate the Offer without the information.

May: Indicates something that is not mandatory but permissible.

For purposes of this solicitation, the following definitions will apply:

"A.R.S." Arizona Revised Statute

"Buyer" or "Procurement Officer" City of Phoenix staff person responsible for the solicitation. The City employee or employees who have specifically been designated to act as a contact person or persons to the Contractor, and responsible for monitoring and overseeing the Contractor's performance under this contract.

"City" The City of Phoenix

"Contractor" The individual, partnership, or corporation who, as a result of the competitive process, is awarded a contract by the City of Phoenix.

"Contract" or "Agreement" The legal agreement executed between the City of Phoenix, AZ and the Contractor.

"Days" Means calendar days unless otherwise specified.

"Chief Procurement Officer" The contracting authority for the City of Phoenix, AZ, authorized to sign contracts and amendments thereto on behalf of the City of Phoenix, AZ.

"Employer" Any individual or type of organization that transacts business in this state, that has a license issued by an agency in this state and employs one or more employees in this state. Employer includes this state, any political subdivision of this state and self-employed persons. In the case of an independent contractor, employer means the independent contractor and does not mean the person or organization that uses contract labor. (A.R.S. 23-211).

"Offer" Means a response from a Supplier, Contractor, or Service Provider to a solicitation request that, if awarded, binds the Supplier, Contractor, or Service Provider to perform in accordance with the contract. Same as bid, proposal, quotation or tender.

"Offeror" Any Vendor, Seller or Supplier submitting a competitive offer in response to a solicitation from the City. Same as Bidder or Proposer.

"Solicitation" Means an Invitation for Bid (IFB), Request for Proposal (RFP), Request for Quotations (RFQ), Request for Qualifications (RFQu) and request for sealed Offers, or any other type of formal procurement which the City makes public through advertising, mailings, or some other method of communication. It is the process by which the City seeks information, proposals, Offers, or quotes from suppliers.

“Suppliers” Firms, entities or individuals furnishing goods or services to the City.

“Vendor or Seller” A seller of goods or services.

4.2. Contract Interpretation

- A. **Applicable Law:** This Contract will be governed by the law of the State of Arizona, and suits pertaining to this Contract will be brought only in Federal or State courts in Maricopa County, State of Arizona.
- B. **Contract Order of Precedence:** In the event of a conflict in the provisions of the Contract, as accepted by the City and as they may be amended, the following will prevail in the order set forth below:
1. Federal terms and conditions, if any
 2. Special terms and conditions
 3. Standard terms and conditions
 4. Amendments
 5. Statement or scope of work
 6. Specifications
 7. Attachments
 8. Exhibits
 9. Instructions to Contractors
 10. Other documents referenced or included in the Solicitation
- C. **Organization – Employment Disclaimer:** The Agreement resulting hereunder is not intended to constitute, create, give rise to or otherwise recognize a joint venture agreement or relationship, partnership or formal business organization of any kind, and the rights and obligations of the parties will be only those expressly set forth in the agreement. The parties agree that no persons supplied by the Contractor in the performance of Contractor’s obligations under the agreement are considered to be City’s employees and that no rights of City civil service, retirement or personnel rules accrue to such persons. The Contractor will have total responsibility for all salaries, wage bonuses, retirement, withholdings, workmen’s compensation, occupational disease compensation, unemployment compensation, other employee benefits and all taxes and premiums appurtenant thereto concerning such persons, and will save and hold the City harmless with respect thereto.
- D. **Severability:** The provisions of this Contract are severable to the extent that any provision or application held to be invalid will not affect any other provision or application of the contract which may remain in effect without the invalid provision or application.

- E. **Non-Waiver of Liability:** The City of Phoenix as a public entity supported by tax monies, in execution of its public trust, cannot agree to waive any lawful or legitimate right to recover monies lawfully due it. Therefore, any Contractor agrees that it will not insist upon or demand any statement whereby the City agrees to limit in advance or waive any right the City might have to recover actual lawful damages in any court of law under applicable Arizona law.
- F. **Parol Evidence:** This Agreement is intended by the parties as a final expression of their agreement and is intended also as a complete and exclusive statement of the terms of this agreement. No course of prior dealings between the parties and no usage in the trade will be relevant to supplement or explain any term used in this Contract. Acceptance or acquiescence in a course of performance rendered under this contract will not be relevant to determine the meaning of this Contract even though the accepting or acquiescing party has knowledge of the nature of the performance and opportunity to object.

4.3. Contract Administration and Operation

- A. **Records:** All books, accounts, reports, files and other records relating to the contract will be subject at all reasonable times to inspection and audit by the City for five years after completion of the contract. Such records will be produced at a City of Phoenix office as designated by the City. Confidentiality will be maintained, and City will not violate any proprietary or other confidentiality agreements vendor has in place.
- B. **Discrimination Prohibited:** Contractor agrees to abide by the provisions of the Phoenix City Code Chapter 18, Article V as amended. Any contractor, in performing under this contract, will not discriminate against any worker, employee or applicant, or any member of the public, because of race, color, religion, sex, national origin, age or disability nor otherwise commit an unfair employment practice. The supplier and/or lessee will take action to ensure that applicants are employed, and employees are dealt with during employment without regard to their race, color, religion, sex, or national origin, age or disability and adhere to a policy to pay equal compensation to men and women who perform jobs that require substantially equal skill, effort and responsibility, and that are performed within the same establishment under similar working conditions. Such action will include but not be limited to the following: Employment, promotion, demotion or transfer, recruitment or recruitment advertising, layoff or termination; rates of pay or other forms of compensation; and selection for training; including apprenticeship. The supplier further agrees that this clause will be incorporated in all subcontracts with all labor organizations furnishing skilled, unskilled and union labor, or who may perform any such labor or services in connection with this contract. Contractor further agrees that this clause will be incorporated in all subcontracts, job-contractor agreements or subleases of this agreement entered into by supplier/lessee.
- C. **Equal Employment Opportunity and Pay:** In order to do business with the City, Contractor must comply with Phoenix City Code, 1969, Chapter 18, Article V, as amended,

Equal Employment Opportunity Requirements. Contractor will direct any questions in regard to these requirements to the Equal Opportunity Department, (602) 262-6790.

1. **For a Contractor with 35 employees or fewer:** Contractor in performing under this Agreement shall not discriminate against any worker, employee or applicant, or any member of the public, because of race, color, religion, sex, national origin, age, or disability, nor otherwise commit an unfair employment practice. The Contractor will ensure that applicants are employed, and employees are dealt with during employment without regard to their race, color, religion, sex, national origin, age, or disability. Such action shall include but not be limited to the following: employment, promotion, demotion or transfer, recruitment or recruitment advertising, layoff or termination; rates of pay or other forms of compensation; and selection for training; including apprenticeship. The Contractor further agrees that this clause will be incorporated in all subcontracts related to this Agreement that involve furnishing skilled, unskilled and union labor, or who may perform any such labor or services in connection with this Agreement. Contractor further agrees that this clause will be incorporated in all subcontracts, Contractor agreements or subleases of this agreement entered into by supplier/lessee.

2. **For a Contractor with more than 35 employees:** Contractor in performing under this Agreement shall not discriminate against any worker, employee or applicant, or any member of the public, because of race, color, religion, sex, national origin, age, or disability, nor otherwise commit an unfair employment practice. The Contractor will ensure that applicants are employed, and employees are dealt with during employment without regard to their race, color, religion, sex, national origin, age, or disability, and shall adhere to a policy to pay equal compensation to men and women who perform jobs that require substantially equal skill, effort, and responsibility, and that are performed within the same establishment under similar working conditions. Such action shall include but not be limited to the following: employment, promotion, demotion or transfer, recruitment or recruitment advertising, layoff or termination; rates of pay or other forms of compensation; and selection for training; including apprenticeship. The Contractor further agrees that this clause will be incorporated in all subcontracts with all labor organizations furnishing skilled, unskilled and union labor, or who may perform any such labor or services in connection with this contract. Contractor further agrees that this clause will be incorporated in all subcontracts, job-Contractor agreements or subleases of this Agreement entered into by supplier/lessee. The Contractor further agrees not to discriminate against any worker, employee or applicant, or any member of the public, because of sexual orientation or gender identity or expression and shall ensure that applicants are employed, and employees are dealt with during employment without regard to their sexual orientation or gender identity or expression.

3. **Documentation:** Suppliers and lessees may be required to provide additional documentation to the Equal Opportunity Department affirming that a nondiscriminatory policy is being utilized.
 4. **Monitoring:** The Equal Opportunity Department shall monitor the employment policies and practices of suppliers and lessees subject to this article as deemed necessary. The Equal Opportunity Department is authorized to conduct on-site compliance reviews of selected firms, which may include an audit of personnel and payroll records, if necessary.
- D. **Legal Worker Requirements:** The City of Phoenix is prohibited by A.R.S. § 41-4401 from awarding a contract to any Contractor who fails, or whose subcontractors fail, to comply with A.R.S. § 23-214(A). Therefore, Contractor agrees that:
1. Contractor and each subcontractor it uses warrants their compliance with all federal immigration laws and regulations that relate to their employees and their compliance with A.R.S. § 23-214, subsection A.
 2. A breach of a warranty under paragraph 1 will be deemed a material breach of the contract that is subject to penalties up to and including termination of the contract.
 3. The City of Phoenix retains the legal right to inspect the papers of any Contractor or subcontractor employee who works on the contract to ensure that the Contractor or subcontractor is complying with the warranty under paragraph 1.
- E. **Health, Environmental, and Safety Requirements:** The Contractor's products, services and facilities will be in full compliance with all applicable Federal, State and local health, environmental and safety laws, regulations, standards, codes and ordinances, regardless of whether or not they are referred to by the City. At the request of City representatives, the Contractor will provide the City:
1. Environmental, safety and health regulatory compliance documents (written safety programs, training records, permits, etc.) applicable to services provided by the Contractor in this contract.
 2. A list of all federal, state, or local (EPA, OSHA, Maricopa County, etc.) citations or notice of violations issued against their firm or their subcontractors including dates, reasons, dispositions and resolutions.
 3. The City will have the right, but not the obligation to inspect the facilities, transportation vehicles or vessels, containers and disposal facilities provided by the Contractor or subcontractor. The City will also have the right to inspect operations conducted by the Contractor or subcontractor in the performance of this agreement. The City further reserves the right to make unannounced inspections of the Contractor's facilities (during normal business hours).
- F. **Compliance with Laws:** Contractor agrees to fully observe and comply with all applicable Federal, State and local laws, regulations, standards, codes and ordinances when

performing under this Contract regardless of whether they are being referred to by the City. Contractor agrees to permit City inspection of Contractor's business records, including personnel records to verify any such compliance. Because the contractor will be acting as an independent contractor, the City assumes no responsibility for the Contractor's acts. Contractor shall comply with the provisions of the Supplemental Terms and Conditions to All Airport Agreements attached, marked Exhibit A, and incorporated herein by this reference.

- G. **Lawful Presence Requirement:** Pursuant to A.R.S. §§ 1-501 and -502, the City of Phoenix is prohibited from awarding a contract to any natural person who cannot establish that he or she is lawfully present in the United States. In order to establish lawful presence, this person must produce qualifying identification and sign a City-provided affidavit affirming that the identification provided is genuine. This requirement will be imposed at the time of contract award. In the event the prevailing responder is unable to satisfy this requirement, the City will offer the award to the next-highest scoring responder. The law does not apply to fictitious entities such as corporations, partnerships and limited liability companies.
- H. **Continuation During Disputes:** Contractor agrees that notwithstanding the existence of any dispute between the parties, insofar as is possible, under the terms of the contract, the Contractor will continue to perform the obligations required of Contractor during the continuation of any such dispute unless enjoined or prohibited by an Arizona Court of competent jurisdiction.
- I. **Emergency Purchases:** The City reserves the right to purchase from other sources those items which are required on an emergency basis and cannot be supplied immediately from stock by the Contractor.

4.4. Costs and Payments

- A. **General:** Any prompt payment terms offered must be clearly noted by the Contractor on all invoices submitted to the City for the payment of goods or services received. The City will make every effort to process payment for the purchase of material or services within thirty to forty-five calendar days after receipt of a correct invoice, unless a good faith dispute exists to any obligation to pay all or a portion of the account. Payment terms are specified in the Offer.
- B. **Payment Deduction Offset Provision:** Contractor acknowledges that the City Charter requires that no payment be made to any Contractor as long as there is an outstanding obligation due to the City. Contractor agrees that any obligation it owes to the City will be offset against any payment due to the Contractor from the City.
- C. **Late Submission of Claim by Contractor:** The City will not honor any invoices or claims which are tendered one year after the last item of the account accrued.

- D. **Discounts:** If applicable, payment discounts will be computed from the date of receiving acceptable products, materials and/or services or correct invoice, whichever is later to the date payment is mailed.
- E. **No Advance Payments:** Advance payments are not authorized. Payment will be made only for actual services or commodities that have been received, unless addressed specifically in the Scope of work for subscription services.
- F. **Fund Appropriation Contingency:** The Contractor recognizes that any agreement entered into will commence upon the day first provided and continue in full force and effect until termination in accordance with its provisions. The Contractor and the City herein recognize that the continuation of any contract after the close of any given fiscal year of the City, which ends on June 30th of each year, will be subject to the approval of the budget of the City providing for or covering such contract item as an expenditure therein. The City does not represent that said budget item will be actually adopted, said determination being the determination of the City Council at the time of the adoption of the budget.
- G. **Maximum Prices:** The City will not be invoiced at prices higher than those stated in any contract resulting from this Offer. Contractor certifies, by signing this Offer that the prices offered are no higher than the lowest price the Contractor charges other buyers for similar quantities under similar conditions, as applicable and shown by quotes for like services and goods. Contractor further agrees that any reductions in the price of the goods or services covered by this Offer and occurring after award will apply to the undelivered balance. The Contractor will promptly notify the City of such price reductions.
- H. **F.O.B. Point:** All prices are to be quoted F.O.B. destination, unless specified elsewhere in this solicitation.

4.5. Contract Changes

- A. **Contract Amendments:** Contracts will be modified only by a written contract amendment signed by persons duly authorized to enter into contracts on behalf of the Contractor. No verbal agreement or conversation with any officer, agent, or employee of the City either before or after execution of the contract, will affect or modify any of the terms or obligations contained or to be contained in the contract. Any such verbal agreements or conversation shall be considered as unofficial information and in no way binding upon the City or the Contractor. All agreements shall be in writing and contract changes shall be by written amendment signed by both parties.
- B. **Assignment - Delegation:** No right or interest in this contract nor monies due hereunder will be assigned in whole or in part without written permission of the City, and no delegation of any duty of Contractor will be made without prior written permission of the City, which may be withheld for good cause. Any assignment or delegation made in violation of this section will be void.

- C. **Non-Exclusive Contract:** Any contract resulting from this solicitation will be awarded with the understanding and agreement that it is for the sole convenience of the City. The City reserves the right to obtain like goods or services from another source when necessary.

4.6. Risk of Loss and Liability

- A. **Title and Risk of Loss:** The title and risk of loss of material or service will not pass to the City until the City actually receives the material or service at the point of delivery; and such loss, injury, or destruction will not release seller from any obligation hereunder.
- B. **Acceptance:** All material or service is subject to final inspection and acceptance by the City. Material or service failing to conform to the specifications of this contract will be held at Contractor's risk and may be returned to the Contractor. If so returned, all costs are the responsibility of the Contractor. Noncompliance will conform to the cancellation clause set forth in this document.
- C. **Force Majeure:** Except for payment of sums due, neither party will be liable to the other nor deemed in default under this contract if and to the extent that such party's performance of this contract is prevented by reason of force majeure. The term "force majeure" means an occurrence that is beyond the control of the party affected and occurs without its fault or negligence. Force majeure will not include late performance by a subcontractor unless the delay arises out of a force majeure occurrence in accordance with this force majeure term and condition. If either party is delayed at any time in the progress of the work by force majeure, the delayed party will notify the other party in writing of such delay, as soon as is practical, of the commencement thereof and will specify the causes of such delay in such notice. Such notice will be hand-delivered or mailed certified-return receipt and will make a specific reference to this provision, thereby invoking its provisions. The delayed party will cause such delay to cease as soon as practicable and will notify the other party in writing when it has done so. The time of completion will be extended by contract modification for a period of time equal to the time that results or effects of such delay prevent the delayed party from performing in accordance with this contract.
- D. **Loss of Materials:** The City does not assume any responsibility, at any time, for the protection of or for loss of materials, from the time that the contract operations have commenced until the final acceptance of the work by the City.
- E. **Contract Performance:** Contractor will furnish all necessary labor, tools, equipment, and supplies to perform the required services at the City facilities designated, unless otherwise specifically addressed in the scope, or elsewhere in this Agreement. The City's authorized representative will decide all questions which may arise as to the quality and acceptability of any work performed under the contract. If, in the opinion of the City's authorized representative, performance becomes unsatisfactory, the City will notify the Contractor. The Contractor will have 30 days from that time to correct any specific instances of unsatisfactory performance, unless a different amount of time is specified in the agreement. In the event the unsatisfactory performance is not corrected within the time specified, the City will have the immediate right to complete the work to its satisfaction and

will deduct the cost to cover from any balances due or to become due the Contractor. Repeated incidences of unsatisfactory performance may result in cancellation of the agreement for default.

- F. **Damage to City Property:** Contractor will perform all work so that no damage to the building or grounds results. Contractor will repair any damage caused to the satisfaction of the City at no cost to the City. Contractor will take care to avoid damage to adjacent finished materials that are to remain. If finished materials are damaged, Contractor will repair and finish to match existing material as approved by the City at Contractor's expense.

4.7. City's Contractual Rights

Whenever one party to this contract in good faith has reason to question the other party's intent to perform, the former party may demand that the other party give a written assurance of this intent to perform. In the event that a demand is made and no written assurance is given within five days, the demanding party may treat this failure as an anticipatory repudiation of this contract.

- A. **Non-Exclusive Remedies:** The rights and remedies of the City under this Contract are non-exclusive.
- B. **Default in One Installment to Constitute Breach:** Each installment or lot of the agreement is dependent on every other installment or lot and a delivery of non-conforming goods or a default of any nature under one installment or lot will impair the value of the whole agreement and constitutes a total breach of the agreement as a whole.
- C. **On Time Delivery:** Because the City is providing services which involve health, safety and welfare of the general public, delivery time is of the essence. Delivery must be made in accordance with the delivery schedule promised by the Contractor.
- D. **Default:** In case of default by the Contractor, the City may, by written notice, cancel this contract and repurchase from another source and may recover the excess costs by (1) deduction from an unpaid balance due; (2) collection against the Solicitation and/or Performance Bond, or (3) a combination of the aforementioned remedies or other remedies as provided by law.
- E. **Covenant Against Contingent Fees:** Seller warrants that no person or selling agent has been employed or retained to solicit or secure this contract upon an agreement or understanding for a commission, percentage, brokerage, or contingent fee, excepting bona fide employers or bona fide established commercial or selling agencies maintained by the seller for the purpose of securing business. For breach or violation of this warranty, the City will have the right to annul the contract without liability or in its discretion to deduct from the contract price a consideration, or otherwise recover the full amount of such commission, brokerage or contingent fee.
- F. **Cost Justification:** In the event only one response is received, the City may require that the Contractor submit a cost proposal in sufficient detail for the City to perform a cost/price analysis to determine if the Offer price is fair and reasonable.

- G. Work Product, Equipment, and Materials:** All work product, equipment, or materials created or purchased under this contract belongs to the City and must be delivered to the City at City's request upon termination of this contract. Contractor agrees to assign to City all rights and interests Contractor may have in materials prepared under this contract that are "works for hire" within the meaning of the copyright laws of the United States, including any right to derivative use of the material.

4.8. Contract Termination

- A. Gratuities:** The City may, by written notice to the Contractor, cancel this contract if it is found that gratuities, in the form of entertainment, gifts or otherwise, were offered or given by the Contractor or any agent or representative of the Contractor, to any officer or employee of the City making any determinations with respect to the performing of such contract. In the event this contract is canceled by the City pursuant to this provision, the City will be entitled, in addition to any other rights and remedies, to recover or withhold from the Contractor the amount of the gratuity.

B. Conditions and Causes for Termination:

1. This contract may be terminated at any time by mutual written consent, or by the City, with or without cause, upon giving thirty-day written notice to Contractor. The City at its convenience, by written notice, may terminate this contract, in whole or in part. If this contract is terminated, the City will be liable only for payment under the payment provisions of this contract for services rendered and accepted material received by the City before the effective date of termination. Title to all materials, work-in-process and completed but undeliverable goods, will pass to the City after costs are claimed and allowed. The Seller will submit detailed cost claims in an acceptable manner and will permit the City to examine such books and records as may be necessary in order to verify the reasonableness of any claims.
2. The City reserves the right to cancel the whole or any part of this contract due to failure of Contractor to carry out any term, promise, or condition of the contract. The City will issue a written notice of default to Contractor for acting or failing to act as in any of the following:
 - In the opinion of the City, Contractor provides personnel who do not meet the requirements of the contract;
 - In the opinion of the City, Contractor fails to perform adequately the stipulations, conditions or services/specifications required in this contract;
 - In the opinion of the City, Contractor attempts to impose on the City personnel or materials, products or workmanship, which is of an unacceptable quality;
 - Contractor fails to furnish the required service and/or product within the time stipulated in the contract;

- In the opinion of the City, Contractor fails to make progress in the performance of the requirements of the contract and/or gives the City a positive indication that Contractor will not or cannot perform to the requirements of the contract.

C. **Contract Cancellation:** All parties acknowledge that this contract is subject to cancellation by the City of Phoenix pursuant to the provision of Section 38-511, Arizona Revised Statutes.

4.9. Notice

All notices, consents, approvals, and other communications ("Notice") between the City and Contractor that are required to be given under this Contract shall be in writing and given by (1) personal delivery, (2) email with return receipt requested (read receipt), (3) facsimile transmittal with delivery confirmation, (4) prepaid delivery to any commercial air courier or express delivery service, or (5) registered or certified mail, postage prepaid and return receipt requested, through the United States Postal Service.

Notices to the City shall be sent to: City of Phoenix Finance Department, Procurement Division Procurement@phoenix.gov.

Notice to Contractor shall be sent to the person at the mailing address, email address, or fax number listed by Contractor in its Offer in Submittal Forms - Offer Page.

4.10. State and Local Transaction Privilege Taxes

In accordance with applicable state and local law, transaction privilege taxes may be applicable to this transaction. The state and local transaction privilege (sales) tax burden and legal liability to remit taxes are on the Contractor that is conducting business in Arizona and the City of Phoenix. Any failure by the Contractor to collect applicable taxes from the City will not relieve the Contractor from its obligation to remit taxes. It is the responsibility of the prospective bidder to determine any applicable taxes. The City will look at the price or offer submitted and will not deduct, add or alter pricing based on speculation or application of any taxes, nor will the City provide advice or guidance. If you have questions regarding your tax liability, please seek advice from a tax professional prior to submitting your Offer. You may also find information at <https://www.phoenix.gov/finance/plt> or <https://www.azdor.gov/Business>. Once your Offer is submitted, the Offer is valid for the time specified in this Solicitation, regardless of mistake or omission of tax liability. If the City finds over payment of a project due to tax consideration that was not due, the Contractor will be liable to the City for that amount, and by contracting with the City, the Contractor agrees to remit any overpayments back to the City for miscalculations on taxes included in an offer price.

4.11. Tax Indemnification

Contractor will pay all federal, state and local taxes applicable to its operation and any persons employed by the Contractor, and require the same of all subcontractors. Contractor will hold the City harmless from any responsibility for taxes, damages and interest, if applicable, contributions required under federal, and/or state and local laws and regulations and any other costs including transaction privilege taxes, unemployment compensation insurance, Social Security and Worker's Compensation, and require the same of all subcontractors.

4.12. Tax Responsibility Qualification

Contractor may be required to establish, to the satisfaction of City, that any and all fees and taxes due to the City or the State of Arizona for any License or Transaction Privilege taxes, Use Taxes or similar excise taxes, are currently paid (except for matters under legal protest). Contractor agrees to a waiver of the confidentiality provisions contained in the City Finance Code and any similar confidentiality provisions contained in Arizona statutes relative to State Transaction Privilege Taxes or Use Taxes. Contractor agrees to provide written authorization to the City Finance Department and to the Arizona State Department of Revenue to release tax information relative to Arizona Transaction Privilege Taxes or Arizona Use Taxes in order to assist the Department in evaluating Contractor's qualifications for and compliance with contract for duration of the term of contract.

4.13. No Israel Boycott

If this Contract is valued at \$100,000 or more and requires Contractor (a company engaging in for-profit activity and having ten or more full-time employees) to acquire or dispose of services, supplies, information technology, or construction, then Contractor must certify and agree that it does not and will not boycott goods or services from Israel, pursuant to Title 35, Chapter 2, Article 9 of the Arizona Revised Statutes. Provided that these statutory requirements are applicable, Contractor by entering this Contract now certifies that it is not currently engaged in, and agrees for the duration of the Contract to not engage in, a boycott of goods or services from Israel.

4.14. No Forced Labor of Ethnic Uyghurs

If this Contract requires Contractor (a company engaging in for-profit activity and having ten or more full-time employees) to acquire or dispose of services, supplies, information technology, goods, or construction, then pursuant to Title 35, Chapter 2, Article 10 of the Arizona Revised Statutes Contractor must certify and agree that it and any contractors, subcontractors, or suppliers it utilizes do not and will not use the forced labor of ethnic Uyghurs in the People's Republic of China or any goods or services produced by such forced labor. Provided these statutory requirements are applicable, Contractor, by entering this Contract, now certifies it is not currently engaged in, and agrees for the duration of the Contract to not engage in, (a) the use of forced labor of ethnic Uyghurs in the People's Republic of China; (b) the use of any goods or services produced by the forced labor of ethnic Uyghurs in the People's Republic of China; or (c) the use of any contractors, subcontractors, or suppliers that use the forced labor or any goods or services produced by the forced labor of ethnic Uyghurs in the People's Republic of China.

4.15. Advertising

Except as required by law, Contractor shall not publish, release, disclose or announce to any member of the public, press, official body, or any other third party any information or documents concerning this Agreement or any part thereof without the prior written consent of the City. The name of any City site on which services are performed by the Contractor pursuant to this Agreement shall not be used in any advertising or other promotional context by Contractor without the prior written consent of the City.

4.16. Strict Performance

Failure of either party to insist upon the strict performance of any item or condition of the contract or to exercise or delay the exercise of any right or remedy provided in the contract, or by law, or

the acceptance of materials or services, obligations imposed by this contract, or by law, will not be deemed a waiver of any right of either party to insist upon the strict performance of the contract.

4.17. Authorized Changes

The City reserves the right at any time to make changes in any one or more of the following: (a) specifications; (b) methods of shipment or packing; (c) place of delivery; (d) time of delivery; and/or (e) quantities. If the change causes an increase or decrease in the cost of or the time required for performance, an equitable adjustment may be made in the price or delivery schedule, or both. Any claim for adjustment will be deemed waived unless asserted in writing within sixty days from the receipt of the change. Price increases or extensions of delivery time will not be binding on the City unless evidenced in writing and approved by the Chief Procurement Officer prior to the institution of the change.

4.18. Attorney Fees

In any contested action related to or arising out of this Contract, the prevailing party shall recover its attorney fees, court costs, and other expenses from the other party. Where there are no competing claims, "prevailing party" means the party that substantially obtained the relief sought. Where there are competing claims, the prevailing party is the net winner or the party who prevailed in a totality of the litigation.

4.19. Headings

Headings for articles, sections, and paragraphs are for reference only and do not limit the content or scope of any provision of this Contract.

4.20. National Emergency

This Contract is subject to the right of the United States to control, operate, and regulate the Airport and to use of the Airport during the time of war or national emergency.

4.21. No Impairment of Title

Contractor and its agents, employees, and contractors shall not cause or allow any person or entity to cause any lien, cloud, charge, or encumbrance to be filed, recorded, or imposed on the Airport or any portion thereof.

4.22. No Personal Liability

The City's officers, officials, agents, and employees are not personally liable to Contractor for any default or breach of this Contract by the City, are not liable for any amount that may become due to Contractor, and are not obligated to perform under any provision of this Contract.

4.23. Successors and Assigns

This Contract binds the parties and their owners, officers, directors, managers, members, agents, employees, representatives, trustees, executors, personal representatives, and successors.

4.24. Termination for Non-Appropriation of Funds

This Contract is contingent on the appropriation of adequate funds by the Phoenix City Council for each fiscal year during the term of this Contract. If adequate funds are not appropriated, then

this Contract shall terminate on June 30 of the last fiscal year for which funds were appropriated. The termination shall be without penalty or any liability by the City.

4.25. Breach and Remedies for Breach

The occurrence of any of the following events shall be deemed a material breach of this Contract by Contractor:

- Contractor fails to pay any amount when due and the failure continues for ten (10) days after notice from the City.
- Except for the non-monetary events of breach listed below, Contractor fails to perform any non-monetary obligation under this Contract and the failure continues for ten (10) days after notice from the City.
- Contractor fails to procure and maintain the insurance coverages required under this Contract and the failure continues for one (1) day after notice from the City.
- Contractor breaches any other lease, contract, agreement, or permit it has with the City.
- Contractor files a voluntary petition in bankruptcy; is adjudicated bankrupt or insolvent; takes the benefit of any law applicable to bankrupt or insolvent debtors; files a petition or action seeking reorganization, arrangement, composition, readjustment, liquidation, dissolution, or similar relief; seeks or acquiesces to the appointment of a trustee, receiver, or liquidator of all or a substantial part of Contractor's assets; or makes any general assignment for the benefit of creditors.
- Contractor violates any federal, state, or local law, rule, regulation, or ordinance related to this Contract and the violation continues for ten (10) days after notice from the City.

Upon the occurrence of any breach by Contractor, the City may elect to do any or all the following at one time or over a period of time:

- File a civil action or actions to, among other things, enforce this Contract and recover all amounts due, all attorney fees, court costs, and other expenses incurred.
- Exercise any and all remedies allowed at law or in equity.
- Recover all attorney fees, court costs, and other expenses incurred, whether or not a civil action or other judicial proceeding is filed.

The City's exercise of any remedy does not terminate and shall not be construed to terminate this Contract. Termination of this Contract must be evidenced by a writing signed by the City for that purpose. The foregoing list of remedies is not exhaustive, and the rights and remedies of the City under this Contract are non-exclusive.

4.26. Claims Against the City

Contractor shall comply with the procedures set forth in Chapter XVIII, § 14 of the Charter of the City of Phoenix (claims or demands against the City) and A.R.S. § 12-821 and § 12-821.01 (notice of claim statutes) for presenting claims or demands against the City. Nothing in this Contract

constitutes a contractual term that requires a dispute resolution process, an administrative claims process, or review process, as those terms are used in A.R.S. § 12-821.01(C), so as to affect the date on which a cause of action accrues under A.R.S. § 12-821.01(A) and (B).

4.27. Delinquent Account Fee

Any amount that is not paid by Contractor when due is deemed delinquent. If the delinquent amount remains unpaid for ten (10) days, then a delinquent account fee of eighteen percent (18%) per annum shall be assessed according to Phoenix City Code § 4-7. Delinquent account fees shall be computed and accrued on a daily basis and assessed until the account balance, including delinquent account fees, is paid in full. Delinquent account fees are due from Contractor upon demand by the City.

4.28. Entire Agreement

This Contract constitutes the entire agreement between the parties and supersedes all prior written and oral agreements, understandings, discussions, proposals, negotiations, communications, representations, and correspondence related to this Contract. The parties are not bound by any obligation not provided for in this Contract. Contractor certifies that it was not induced to enter into this Contract by any misrepresentation, undue influence, or coercion by the City or any of its officers, officials, agents, or employees. The Exhibits attached to this Contract are material parts of this Contract and are incorporated herein by this reference.

4.29. Fair Interpretation

Contractor agrees that the rule that ambiguous or vague language in a contract is construed against the drafter is waived and does not apply to this Contract. Contractor agrees that this Contract shall be interpreted fairly and not against the City simply because the City drafted this Contract.

4.30. No Third-Party Beneficiaries

Except as expressly provided in this Contract, nothing contained herein creates or may be construed to create any right or privilege in any person or entity that is not a party to this Contract.

4.31. Contractor Requirements for the Mitigation of Heat-Related Illnesses and Injuries in the Workplace

Any contractor whose employees and contract workers perform work in an outdoor environment under this contract must keep on file a written heat safety plan. The city may request a copy of this plan and documentation of all heat safety and mitigation efforts currently implemented to prevent heat-related illnesses and injuries in the workplace. The plan must also be posted where it is accessible to employees. At a minimum, the heat safety and mitigation plan and documentation required under this provision shall include each of the following as it relates to heat safety and mitigation:

- A. Availability of sanitized cool drinking water free of charge at locations that are accessible to all employees and contract workers.
- B. Ability to take regular and necessary breaks as needed and additional breaks for hydration.

- C. Access to shaded areas and/or air conditioning.
- D. Access to air conditioning in vehicles with enclosed cabs. All such vehicles must contain functioning air conditioning by no later than May 1, 2025.
- E. Effective acclimatization practices to promote the physiological adaptations of employees or contract workers newly assigned or reassigned to work in an outside environment.
- F. Conduct training and make it available and understandable to all employees and contract workers on heat illness and injury that focuses on the environmental and personal risk factors, prevention, how to recognize and report signs and symptoms of heat illness and injury, how to administer appropriate first aid measures and how to report heat illness and injury to emergency medical personnel.

The contractor further agrees that this clause will be incorporated in all subcontracts with subcontractors, sublicensees or sublessees who may perform labor or services in connection with this contract. Additionally, the contractor agrees to require all subcontractors, sublicensees or sublessees to include this clause in all contracts with any third party who is contracted to perform labor or services in connection with this contract. It is the obligation of the contractor to ensure compliance by its subcontractors.

4.32. Title VI Solicitation Notice

The City of Phoenix, in accordance with the provisions of Title VI of the Civil Rights Act of 1964 (78 Stat. 252, 42 U.S.C. §§ 2000d to 2000d-4) and the Regulations, hereby notifies all bidders that it will affirmatively ensure that for any contract entered into pursuant to this advertisement, disadvantaged business enterprises and airport concession disadvantaged business enterprises will be afforded full and fair opportunity to submit bids in response to this invitation and will not be discriminated against on the grounds of race, color, or national origin in consideration for an award.

5. Special Terms and Conditions

5.1. Term of Contract

The term of this Contract will commence on or about April 1, 2025, and will continue for a period of five years thereafter.

5.2. Free on Board (FOB)

Prices quoted shall be FOB destination and delivered, as required, to the following point(s): various locations in Phoenix Metropolitan Area.

5.3. Price

All prices submitted shall be firm and fixed for the initial two-years of the contract. Thereafter, price increases will be considered annually provided the adjustments are submitted in writing with 60 days' notice to the Procurement Officer. Price increase requests shall be accompanied with written documentation to support the increase, such as a letter from the manufacturer, published price index, applicable change in law, etc. Price decrease requests do not require supporting documentation and are allowed at any time during the contract term.

The City will be the sole judge in determining the allowable increase amount. Price increases agreed to by any staff other than the Chief Procurement Officer are invalid. The Contractor acknowledges and agrees to repay all monies paid because of a requested price increase unless the increase was specifically approved, in writing, by the Chief Procurement Officer.

5.4. Discounts from Published Catalogs / Price Lists

Contractor must indicate and provide with its submittal, if reasonable, the manufacturer's price list, or catalog that will be in effect at the commencement of the contract and from which the discounts offered will be evaluated. The Procurement Officer must be informed 60 days in advance of any new price list or catalogs and the respective date(s).

Any terms and conditions contained in the parts price list(s) or catalog(s) will not take precedence over the City's terms and conditions specified herein.

- A. All discounts offered will be firm and fixed for the entire contract period. Discounts offered must be expressed as a single percentage (%) figure for each contract item. Offers containing chain or multiple discounts may be considered non-responsive.
- B. Offers will be submitted based on a discount from a manufacturer's most recent Published Price List(s) or Catalog which is common to, and accepted by, the industry in general. The lists must be printed or available online, properly identified, and dated as to issuance and effectiveness.

Revised Price Lists or Catalogs may be used as a means of price adjustment. However, all offers are to be firm for a period of two-years after the solicitation due date and pricing cannot be revised during that time. Revised pricing will be accepted only in the event of an industry-wide price change, as evidenced by the issuance of revised price lists, by the manufacturer. Price adjustments will not be made for changes in freight costs. New pricing will not become effective until revised list(s) are submitted to the City under Contractor cover letter identifying the applicable

contract number. Contractor cover letter and pricing list(s) must be date, signed, and submitted to the Procurement Officer. One of revised price list will be required.

- A. All invoices must include the manufacturer's part number, list price and discount percentage, net price extended and totaled. The City reserves the right to request a hard copy of the manufacturer's documented price listing for any item(s) invoiced.

5.5. Method of Ordering

Contractor shall deliver items and/or services only upon receipt of a written purchase order. All Contractor invoices and packing/delivery tickets must include the City of Phoenix purchase order number.

5.6. Method of Invoicing

Invoice must be emailed in .pdf format to invoices@phoenix.gov and must include the following:

- City purchase order number or shopping cart number
- Items listed individually by the written description and part number
- Unit price, extended and totaled
- Quantity ordered, back ordered, and shipped
- Applicable tax
- Invoice number and date
- Delivery address
- Payment terms
- FOB terms
- Remit to address

5.7. Method of Payment

Payment to be made from Contractor's invoice and a copy of the signed delivery/service ticket submitted to cover items received and accepted during the billing period.

5.8. Partial Payments

Partial payments are authorized on individual purchase orders. Payment will be made for actual goods and services received and accepted by the City.

5.9. Supplier Profile Changes

It is the responsibility of the Contractor to promptly update their profile in procurePHX at <https://www.phoenix.gov/procure>. If Contractor's legal identify has changed, the Procurement Officer must be notified immediately. Failure to do so may result in non-payment of invoices and contract termination.

5.10. Estimated Quantities or Dollar Amounts (Requirements Contracts Only)

Quantities and dollar amounts listed are the City's best estimate and do not obligate the City to order or accept more than City's actual requirements during the period of this agreement, as determined by actual needs and availability or appropriated funds. It is expressly understood and agreed that the resulting contract is to supply the City with its complete actual requirement for the contract period.

5.11. Suspensions of Work

The City reserves the right to suspend work wholly or in part if deemed necessary for the best interest of the City. This suspension will be without compensation to the Contractor, other than to adjust the contract completion/delivery requirements.

5.12. Hours of Work

All work under this contract shall be coordinated with the City's authorized Department representative. Any changes to the established schedule must have prior written approval by the City's authorized Department representative.

5.13. Post Award Conference

A post-award conference will be held prior to commencement of any work on the project. The purpose of this conference is to discuss critical elements of the work schedule and operational problems and procedures.

5.14. Performance Interference

Contractor shall notify the City's authorized Department representative immediately of any occurrence and/or condition that interferes with the full performance of the contract and confirm it in writing within 24 hours.

5.15. Cooperative Agreement

In addition to the City and with approval of the Contractor, this contract may be extended for use by other municipalities and government agencies in the State of Arizona.

5.16. Exclusive Possession

All services, information, computer program elements, reports, and other deliverables which may be created under this contract are the sole property of the City of Phoenix and will not be used by the Contractor or any other person except with prior written permission by the City.

5.17. Licenses and Permits

Contractor will keep current Federal, State, and local licenses and permits required for the operation of the business conducted by the Contractor as applicable to this contract.

5.18. Delivery / Service Ticket

Contractor shall provide a packing list or service ticket for items delivered to the City or services provided to the City. Tickets should include the following and a legible copy shall be provided to the City:

- Date
- City purchase order number
- Written description of services which were provided
- Itemized list of materials which were delivered, including quantity
- A unique identification number and Contractor name
- Signature of City employee who accepted for the materials/services

5.19. Miscellaneous Fees

Additional charges for fuel surcharges, delivery charges, dealer prep, environmental fees, waste disposal, shop supplies, set-up, freight and/or shipping and handling, etc. will not be paid. These costs must be incorporated in the pricing provided.

Labor rates (Shop and On-site) shall be charged as a flat hourly rate and are allowed only in performance of services under this agreement. Travel hours and other incidental fees will not be permitted under this agreement. Labor hours will be from “check-in” to “check-out” at the worksite.

5.20. Warranty

All equipment supplied under this contract shall be fully guaranteed by the Contractor for a minimum period of one year from the date of acceptance by the City. Any defects of design, workmanship, or materials that would result in non-compliance with the contract specifications shall be fully corrected by the Contractor (including parts and labor) without cost to the City.

5.21. Equipment Installation

All equipment shall be completely assembled and installed by the Contractor and ready for use on the City’s property at various locations in Phoenix Metropolitan Area.

5.22. Industry Standards

It is intended that the manufacturer in the selection of components will use material and design practices that are the best available in the industry for the type of operating conditions to which the item will be subjected. Component parts shall be selected to give maximum performance, service life and safety and not merely meet the minimum requirements of this specification. All parts, equipment and accessories shall conform in strength, quality of material and workmanship to recognized industry standards.

The term “heavy duty” if used in these specifications shall mean that the item to which the term is applied shall exceed the usual quantity, quality, or capacity supplied with standard production items and it shall be able to withstand unusual straining, exposure, temperature, wear and use.

The City reserves the right to waive minor variations if, in the opinion of the City’s authorized Department representative, the basic unit meets the general intent of these specifications.

The product offered shall not include a major component that is of a prototype nature or has not been in production for a sufficient length of time to demonstrate reliability.

If the specifications stated herein for component items do not comply with legal requirements, the Contractor shall so notify the City prior to the offer opening due date.

5.23. Inspection and Acceptance

Each product delivered shall be subject to complete inspection by the City prior to acceptance. Inspection criteria shall include, but not be limited to, conformity to the specifications, mechanical integrity, quality, workmanship and materials. Ten business days will be allowed for this process. If delivered items are unacceptable and returned to the Contractor prior to acceptance, an additional five business days will be allowed for inspection when subsequent delivery occurs. It shall be the Contractor's responsibility to pick up unacceptable products, correct the deficiencies, and return the product following the corrections.

5.24. Inventory Levels

Contractor's inventory levels of the items may be a factor in the City's award decision. Contractor will be required to maintain sufficient local inventory to provide daily support of the City's requirement. Failure to supply sufficient support may result in cancellation of the contract.

5.25. New Equipment

All items offered shall be new equipment supplied from the manufacturer. Offers for remanufactured/refurbished equipment will be considered as non-responsive and rejected.

5.26. Product Discontinuance

The City may award contracts for products and/or models of equipment because of this solicitation. If a product or model is discontinued by the manufacturer, the City, in its sole discretion, may allow the Contractor to provide a substitute for the discontinued item. Contractor shall request permission to substitute a new product or model and will provide the following:

- A formal announcement from the manufacturer that the product or model has been discontinued.
- Documentation from the manufacturer that names the replacement product or model.
- Documentation that provides clear and convincing evidence that the replacement meets or exceeds all specifications required by the original solicitation.
- Documentation that provides clear and convincing evidence that the replacement will be compatible with all functions or uses of the discontinued product or model.
- Documentation from the manufacturer confirming that the price for the replacement item will be the same as the discontinued item.
- The Chief Procurement Officer will be the sole judge in determining the allowable substitute, new product or model change for discontinued item.

5.27. Contractor Assignments

The Contractor hereby agrees that any of its employees who may be assigned to a City site to satisfy obligations under this contract shall be used exclusively for that purpose during the hours

when they are working in areas covered by this contract and shall perform no work at other City facilities. If other services, in addition to or separate from, the services specified herein, may be deemed necessary by the Chief Procurement Officer or his authorized representative, the Contractor may be requested to perform the additional or special service.

5.28. Final Inspection and Approval

The Contractor will request the City's authorized Department representative to conduct a site inspection after the project is complete. City's authorized Department representative will prepare a "punch-list" during the inspection and will forward a copy to the Contractor.

After the "punch-list" items have been corrected, the Contractor will request a final inspection with the authorized Department representative. Final project approval is contingent upon the City authorized Department representative's final inspection and written approval.

5.29. Specifications

The specifications and/or drawings associated with this project are intended to generally describe a complete installation. Any additional materials or labor required for the complete project as intended shall be provided by the Contractor, even if it has not been detailed in this document.

5.30. Transition of Contract

Contractor will, without limitation, provide important information to a successor Contractor and the City to ensure continuity of service at the required level of proficiency and agrees to provide to the City all files, supplies, data, records, and any other properties or materials of the City, which the City owns or has rights to pursuant to this contract and which are in the possession of Contractor. The provisions of this section will survive the expiration or termination of this contract.

5.31. Types of Work Supervision

The Contractor shall provide onsite supervision and appropriate training to assure competent performance of the work. Contractor or authorized agent will make sufficient daily routine inspections to ensure the work is performed as required by this contract.

5.32. Handling of Photographs

The US Department of Homeland Security has designated water and wastewater treatment facilities as 'critical infrastructure/key resources'. Because of federal directives, only persons authorized by the WSD Security Management Unit are permitted to photograph or film Water infrastructure, facilities, and assets which any include, but are not limited to: pay stations, warehouses, lift stations, treatment plants, service yards, booster stations, well sites, vehicles and related equipment and supplies.

6. Defense and Indemnification

6.1. Standard General Defense and Indemnification

Contractor (“Indemnitor”) must defend, indemnify, and hold harmless the City of Phoenix and its officers, officials (elected or appointed), agents, and employees (“Indemnitee”) from and against any and all claims, actions, liabilities, damages, losses or expenses (including but not limited to court costs, attorney fees, expert fees, and costs of claim processing, investigation and litigation) of any nature or kind whatsoever (“Losses”) caused, or alleged to be caused, in whole or in part, by the wrongful, negligent or willful acts, or errors or omissions of Indemnitor or any of its owners, officers, directors, members, managers, agents, employees or subcontractors (“Indemnitor’s Agents”) arising out of or in connection with this Contract. This defense and indemnity obligation includes holding Indemnitee harmless for any Losses arising out of or recovered under any state’s Workers’ Compensation Law or arising out of the failure of Indemnitor or Indemnitor’s Agents to conform to any federal, state or local law, statute, ordinance, rule, regulation or court decree. Indemnitor’s duty to defend Indemnitee accrues immediately at the time a claim is threatened or a claim is made against Indemnitee, whichever is first. Indemnitor’s duty to defend exists regardless of whether Indemnitor is ultimately found liable. Indemnitor must indemnify Indemnitee from and against any and all Losses, except where it is proven that those Losses are solely a result of Indemnitee’s own negligent or willful acts or omissions. Indemnitor will be responsible for primary loss investigation, defense and judgment costs where this indemnification applies. In consideration of the award of this Contract, Indemnitor waives all rights of subrogation against Indemnitee for losses arising from the work performed by Indemnitor or Indemnitor’s Agents for the City of Phoenix. The obligations of Indemnitor under this provision survive the termination or expiration of this Contract.

7. Insurance Requirements

7.1. Contractor's Insurance

Contractor and subcontractors must procure insurance against claims that may arise from or relate to performance of the work hereunder by Contractor and its agents, representatives, employees and subcontractors. Contractor and subcontractors must maintain that insurance until all their obligations have been discharged, including any warranty periods under this Contract.

The City in no way warrants that the limits stated in this section are sufficient to protect the Contractor from liabilities that might arise out of the performance of the work under this Contract by the Contractor, its agents, representatives, employees or subcontractors and Contractor may purchase additional insurance as they determine necessary.

7.2. Scope and Limits of Insurance

Contractor must provide coverage with limits of liability not less than those stated below. An excess liability policy or umbrella liability policy may be used to meet the liability limits provided that (1) the coverage is written on a "following form" basis, and (2) all terms under each line of coverage below are met.

7.3. Commercial General Liability – Occurrence Form

General Aggregate \$2,000,000

Products – Completed Operations Aggregate \$1,000,000

Personal and Advertising Injury \$1,000,000

Each Occurrence \$1,000,000

- The policy must name the City of Phoenix as an additional insured with respect to liability for bodily injury, property damage and personal and advertising injury with respect to premises, ongoing operations, products and completed operations and liability assumed under an insured contract arising out of the activities performed by, or on behalf of the Contractor related to this Contract.
- There shall be no endorsement or modification which limits the scope of coverage or the policy limits available to the City of Phoenix as an additional insured.
- City of Phoenix is an additional insured to the full limits of liability purchased by the Contractor.
- The Contractor's insurance coverage must be primary and non-contributory with respect to any insurance or self-insurance carried by the City.

7.4. Automobile Liability

Bodily Injury and Property Damage coverage for any owned, hired, and non-owned vehicles used in the performance of this Contract.

Combined Single Limit (CSL) \$1,000,000

- The policy must be endorsed to include the City of Phoenix as an additional insured with respect to liability arising out of the activities performed by, or on behalf of the Contractor, relating to this Contract.
- City of Phoenix is an additional insured to the full limits of liability purchased by the Contractor.
- The Contractor's insurance coverage must be primary and non-contributory with respect to any insurance or self-insurance carried by the City.

7.5. Worker's Compensation and Employers' Liability

Workers' Compensation Statutory

Employers' Liability:

Each Accident \$100,000

Disease – Each Employee \$100,000

Disease – Policy Limit \$500,000

- Policy must contain a waiver of subrogation against the City of Phoenix.
- This requirement does not apply when a contractor or subcontractor is exempt under A.R.S. §23-902(E), **AND** when such contractor or subcontractor executes the appropriate sole proprietor waiver form.

7.6. Notice of Cancellation

For each insurance policy required by the insurance provisions of this Contract, the Contractor must provide to the City, within 5 business days of receipt, a notice if a policy is suspended, voided or cancelled for any reason. Such notice must be mailed, emailed, or hand delivered to City of Phoenix Finance Department, Procurement Division, 251 W Washington Street, Phoenix, AZ 85003 OR procurement@phoenix.gov.

7.7. Acceptability of Insurers

Insurance is to be placed with insurers duly licensed or authorized to do business in the state of Arizona and with an "A.M. Best" rating of not less than B+ VI. The City in no way warrants that the required minimum insurer rating is sufficient to protect the Contractor from potential insurer insolvency.

7.8. Verification of Coverage

Contractor must furnish the City with certificates of insurance (ACORD form or equivalent approved by the City) as required by this Contract. The certificates for each insurance policy are to be signed by a person authorized by that insurer to bind coverage on its behalf.

All certificates and any required endorsements are to be received and approved by the City before work commences. Each insurance policy required by this Contract must be in effect at or prior to commencement of work under this Contract and remain in effect for the duration of the project. Failure to maintain the insurance policies as required by this Contract or to provide evidence of renewal is a material breach of contract.

All certificates required by this Contract must be sent directly to City of Phoenix Finance Department, Procurement Division, 251 W Washington Street, Phoenix, AZ 85003 OR procurement@phoenix.gov. The City project/contract number and project description must be noted on the certificate of insurance. The City reserves the right to review complete copies of all insurance policies required by this Contract at any time. **DO NOT SEND CERTIFICATES OF INSURANCE TO THE CITY'S RISK MANAGEMENT DIVISION.**

7.9. Subcontractors

Contractor's certificates shall include all subcontractors as additional insureds under its policies **OR** Contractor shall be responsible for ensuring and verifying that all subcontractors have valid and collectable insurance. At any time throughout the life of the contract, the City of Phoenix reserves the right to require proof from the Contractor that its subcontractors have insurance coverage. All subcontractors providing services included under this Contract's Scope of Services are subject to the insurance coverages identified above and must include the City of Phoenix as an additional insured. In certain circumstances, the Contractor may, on behalf of its subcontractors, waive a specific type of coverage or limit of liability where appropriate to the type of work being performed under the subcontract. Contractor assumes liability for all subcontractors with respect to this Contract.

7.10. Approval

Any modification or variation from the insurance coverages and conditions in this Contract must be documented by an executed contract amendment.

8. Submittals

8.1. Copies

Please submit one electronic copy of the Submittal Section and all other required documentation. Please do not lock the electronic copy with password protection so that the City may incorporate the successful Offer into the awarded contract.

Please submit only the Submittal Section, do not submit a copy of the entire solicitation document. This Offer will remain in effect for a period of 180 calendar days from the opening date, and is irrevocable unless it is in the City's best interest to release offer(s).

8.2. Solicitation Response Check List

Use this check list as a tool to review your submission to ensure that all required documents and forms are included.

The written offer should be:

- Typewritten for ease of evaluation
- Signed by an authorized representative of the Offeror
- Submitted with contact information for the individual(s) authorized to negotiate with the City
- A. Pricing Proposal - A completed pricing proposal with all requested prices and discounts completed.
- B. Submittal Section forms - All submittal section forms are completed and signed.
 1. 24 Hour emergency Contact
 2. Warranty
 3. Years in Business and References
 4. Costs and Payments
 5. Offer Page
 6. Conflict of Interest and Transparency Form
- C. Addenda - Signed copies of all published addenda.

Offers must be in possession of the Department on or prior to the exact time and date indicated in the Schedule of Events. Late offers will not be considered. Electronic submission is preferred. Due to file size limitations for electronic transmission, offers sent by email may need to be sent in parts with multiple emails. It is the responsibility of the Offeror to ensure that the offer is received timely and that there are no technical reasons for delay. Please refer to the Instructions Section for complete information regarding the submission of offers.

8.3. Additional Quantities

The City anticipates considerable activity under the resultant contract(s). However, no guarantee can be made as to actual signage products and services, that will be purchased under this

contract. The City reserves the right to add, change or delete quantities or items as circumstances may require.

8.4. Catalogs and Price Lists

Contractor must provide with its submittal the date of the current manufacturer's price list, and must identify the catalog that will be in effect at the commencement of the contract and from which the discounts offered will be evaluated. City's Finance Procurement Division must be informed 60 days in advance of any new price list or catalogs and the respective date(s). Any terms and conditions contained in the parts price list(s) or product catalog(s) submitted shall not take precedence over the City's terms and conditions specified herein. All invoices must include the manufacturer's part number, list price and discount percentage, net price extended and totaled. The City reserves the right to request a hard copy of the manufacturer's documented price listing for any item(s) invoiced.

8.5. Discount

All discounts offered shall be firm and fixed for the specified contract period. Discounts offered must be expressed as a single percentage (%) figure for each contract item. Offers containing chain or multiple discounts may be considered non-responsive.

8.6. Discount from Published Price List

Solicitations shall be submitted on the basis of a discount from a manufacturer's most recent Published Price List(s). Such Published Price List(s) must be common to, and accepted by, the industry in general. The lists must be printed, properly identified, and dated as to issuance and effectiveness.

Revised Published Price Lists may be used as a means of price adjustment. However, all offers are to be firm for a period two-years after the solicitation opening date and Revised Price Lists will not be accepted by the City until after that date. Revised Published Price Lists will be accepted only in the event of an industry-wide price change, as evidenced by the issuance of revised price lists, by the manufacturer. Price adjustments will not be made for changes in freight costs.

Revised Published Price(s) will not become effective until revised list(s) are submitted to the City under Contractor cover letter identifying the applicable contract agreement number. Contractor cover letter and pricing list(s) must be dated, signed, and submitted to the Procurement Officer. One of revised price list will be required.

**EXHIBIT A - SUPPLEMENTAL TERMS AND
CONDITIONS TO ALL AIRPORT
AGREEMENTS**

1. Definitions

1.1 "Airport" means Phoenix Sky Harbor International Airport, Phoenix Deer Valley Airport, and/or Phoenix Goodyear Airport, according to the context of the contract.

1.2 "Contract" means all City of Phoenix Aviation Department contracts, subcontracts, agreements, leases, subleases, licenses, permits, concessions, and other documents, however denominated, that grant or convey a right or privilege on an Airport and to which this Exhibit is attached.

1.3 "Contractor" means all lessees, sublessees, licensees, permittees, consultants, concessionaires and other persons, firms, or corporations exercising a right or privilege on an Airport pursuant to a Contract and includes Contractor's heirs, personal representatives, successors, and assigns.

1.4 "Premises" means the area of an Airport occupied or used by Contractor pursuant to a Contract.

2. Federal Aviation Administration (FAA) Grant Assurances

2.1 Title VI of the Civil Rights Act of 1964 – Compliance with Nondiscrimination Requirements – 49 U.S.C. § 47123 and FAA Order 1400.11

During the performance of this Contract, Contractor, for itself, its assignees, and successors in interest (hereinafter referred to as the "Contractor"), agrees as follows:

1. Compliance with Regulations. Contractor (hereinafter includes consultants) will comply with the Title VI List of Pertinent Nondiscrimination Acts and Authorities as they may be amended from time to time, which are herein incorporated by reference and made a part of this contract.

2. Nondiscrimination. The Contractor, with regard to the work performed by it during the Contract, will not discriminate on the grounds of race, color, national origin (including limited English proficiency), creed, sex (including sexual orientation and gender identity), age or disability in the selection and retention of subcontractors, including procurements of materials and leases of equipment. The Contractor will not participate, directly or indirectly in the discrimination prohibited by the Nondiscrimination Acts and Authorities, including employment practices when the Contract covers any activity, project, or program set forth in Appendix B of 49 CFR Part 21.

3. Solicitations for Subcontracts, Including Procurements of Materials and Equipment: In all solicitations, either by competitive bidding or negotiation made by the Contractor for work to be performed under a subcontract, including procurements of materials, or leases of equipment, each potential subcontractor or supplier will be notified by Contractor of the Contractor's obligations under this Contract and Nondiscrimination Acts and Authorities on the grounds of race, color, or national origin.

4. Information and Reports. The Contractor will provide all information and reports required by the Acts and Regulations, and directives issued pursuant thereto and will permit access to its books, records, accounts, other sources of information, and its facilities as may be determined by the City of Phoenix or the Federal Aviation Administration to be pertinent to ascertain compliance with such Nondiscrimination Acts and Authorities and instructions. Where any information required of a Contractor is in the exclusive possession of another who fails or refuses to furnish the information, the Contractor will so certify to the City of Phoenix or the Federal Aviation Administration, as appropriate, and will set forth what efforts it Contractor has made to obtain the information.

5. Sanctions for Noncompliance. In the event of Contractor's noncompliance with the nondiscrimination provisions of this Contract, the City of Phoenix will impose such Contract sanctions as it or the Federal Aviation Administration may determine to be appropriate, including, but not limited to:

(i) Withholding payments to the Contractor under the Contract until Contractor complies, and/or

(ii) Cancelling, terminating, or suspending this Contract, in whole or in part.

6. Incorporation of Provisions. The Contractor will include the provisions of paragraphs one through six in every subcontract, including procurements of materials and leases of equipment, unless exempt by the Acts, the Regulations, and directives issued pursuant thereto. Contractor will take action with respect to any subcontract or procurement as the City of Phoenix or the Federal Aviation Administration may direct as a means of enforcing such provisions, including sanctions for noncompliance. Provided, that if Contractor becomes involved in, or is threatened with litigation by a subcontractor, or supplier because of such direction, Contractor may request the City of Phoenix to enter into any litigation to protect the interests of the City of Phoenix. In addition, Contractor may request the United States to enter into the litigation to protect the interests of the United States.

2.2. Transfer of Real Property Acquired or Improved Under the Airport Improvement Program.

The following clauses will be included in deeds, licenses, leases, permits, or similar

instruments entered into by the City pursuant to the provisions of the Airport Improvement Program grant assurances:

A. Contractor for himself/herself, his/her heirs, personal representatives, successors in interest, and assigns, as a part of the consideration hereof, does hereby covenant and agree (in the case of deeds and leases add, "as a covenant running with the land") that:

1. In the event facilities are constructed, maintained, or otherwise operated on the property described in this Contract for a purpose for which a Federal Aviation Administration activity, facility, or program is extended or for another purpose involving the provision of similar services or benefits, Contractor will maintain and operate such facilities and services in compliance with all requirements imposed by the Nondiscrimination Acts and Regulations listed in the Title VI List of Pertinent Nondiscrimination Acts and Authorities (as may be amended) such that no person on the grounds of race, color, or national origin will be excluded from participation in, denied the benefits of, or be otherwise subjected to discrimination in the use of said facilities.

B. With respect to licenses, leases, permits or similar documents, in the event of a breach of any of the above Nondiscrimination covenants, the City of Phoenix will have the right to terminate this Contract and to enter, re-enter and repossess said lands and facilities thereon, and hold the same as if this Contract had never been made or issued.

C. With respect to a deed, in the event of breach of any of the above Nondiscrimination covenants, the City of Phoenix will have the right to enter or re-enter the lands and facilities thereon, and the above-described lands and facilities will there upon revert to and vest in and become the absolute property of the City of Phoenix and its assigns.

2.3 CLAUSES FOR CONSTRUCTION/USE/ACCESS TO REAL PROPERTY ACQUIRED UNDER THE ACTIVITY, FACILITY OR PROGRAM

The following clauses will be included in deeds, licenses, permits, or similar instruments/agreements entered into by the City pursuant to the provisions of the Airport Improvement Program grant assurances.

A. The grantee, licensee, permittee or as appropriate, for himself/herself, his/her heirs, personal representatives, successors in interest, and assigns, as a part of the consideration hereof, does hereby covenant and agree (in the case of deeds and leases add, "as a covenant running with the land") that (1) no person on the ground of race, color, or national origin, will be excluded from participation in, denied the benefits of, or be otherwise subjected to discrimination in the use of said facilities, (2) that in the construction of any improvements on, over, or

under such land, and the furnishing of services thereon, no person on the ground of race, color, or national origin, will be excluded from participation in, denied the benefits of, or otherwise be subjected to discrimination, (3) that the grantee, licensee, lessee, permittee, or similarly situated person will use the premises in compliance with all other requirements imposed by or pursuant to the Title VI List of Pertinent Nondiscrimination Acts and Authorities.

B. With respect to licenses, leases, permits, or other similar documents, in the event of breach of any of the above Non-discrimination covenants, the City will have the right to terminate the license, permit, or other similar documents, and to enter or re-enter and repossess said land and the facilities thereon, and hold the same as if said license, permit, or other similar documents had never been made or issued.

C. With respect to deeds, in the event of breach of any of the above Non-discrimination covenants, the City will there upon revert to and vest in and become the absolute property of the City and its assigns.

2.4. General Civil Rights Provisions (49 U.S.C. § 47123) Used for Contracts, Lease Agreements, and Transfer Agreements

A. General Civil Rights Provisions: In all its activities within the scope of its airport program, Contractor agrees to comply with pertinent statutes, Executive Orders, and such rules as identified in Title VI List of Pertinent Nondiscrimination Acts and Authorities to ensure that no person shall, on the grounds of race, color, national origin (including limited English proficiency), creed, sex (including sexual orientation and gender identity), age, or disability be excluded from participating in any activity conducted with or benefiting from Federal assistance.

This provision is in addition to that required by title VI of the Civil Rights Act of 1964.

1. Specific Clause that Is Used for General Contract Agreements:

The above provision binds Contractor and subcontractors from the bid solicitation period through the completion of this Contract.

2. Specific Clause that Is Used for Lease Agreements or Transfer Agreements:

If Contractor transfers its obligation to another, the transferee is obligated in the same manner as Contractor.

The above provision obligates Contractor for the period during which the property is owned, used or possessed by Contract and the City of Phoenix remains obligated to the Federal Aviation Administration.

2.5 Economic Nondiscrimination – 49 U.S.C. § 47107

In any Contract under which a right or privilege on the Airport is granted to a Contractor to conduct or to engage in any aeronautical activity for furnishing services to the public, Contractor shall:

A. Furnish its services on a reasonable, and not unjustly discriminatory basis to all users of the Airport, and

B. Charge reasonable, and not unjustly discriminatory prices for each unit or services, provided that Contractor may be allowed to make reasonable and non-discriminatory discounts, rebates, or other similar types of price reductions to volume purchasers. Non-compliance with this requirement shall be a material breach of this Contract for which the City of Phoenix shall have the right to terminate this Contract and any estate created herewith without liability therefor or, at the election of the City of Phoenix or the United States shall have the right to judicially enforce said requirement.

2.6 Disadvantaged Business Enterprise Requirements – 49 C.F.R. Part 26

A. Contract Assurance (§ 26.13). To the extent that this Contract is covered by 49 C.F.R. Part 26, Contractor agrees that this Contract is subject to the requirements of the U.S. Department of Transportation (DOT) regulations at 49 C.F.R. Part 26.

The Contractor, subrecipient or subcontractor shall not discriminate on the basis of race, color, national origin, or sex in the performance of this contract. The Contractor shall carry out applicable requirements of 49 CFR part 26 in the award and administration of DOT-assisted contracts. Failure by the Contractor to carry out these requirements is a material breach of this contract, which may result in the termination of this contract or such other remedy as the recipient deems appropriate, which may include, but is not limited to:

- 1) Withholding monthly progress payments;
- 2) Assessing sanctions;
- 3) Liquidated damages; and/or
- 4) Disqualifying the Contractor from future bidding as non-responsible.

Contractor agrees to include the foregoing statement in any subsequent contract that it enters into and cause those businesses to similarly include the statement in further agreements.

B. Prompt Payment (§ 26.29). Contractor agrees to pay each subcontractor under this Contract for satisfactory performance of its contract not later

than seven (7) days from the receipt of each payment Contractor receives from City of Phoenix. Contractor agrees further to return retainage payments to each subcontractor within seven (7) days after the subcontractor's work is satisfactorily completed. Any delay or postponement of payment from the above-referenced time frame may occur only for good cause following written approval of the City of Phoenix. This clause applies to both DBE and non-DBE subcontractors.

2.7 Airport Concessions Disadvantaged Business Enterprise Requirements – 49 C.F.R. Part 23

Contract Assurance (§ 23.9). To the extent that this Contract is a concession agreement subject to the requirements of the U.S. Department of Transportation's regulations, 49 C.F.R. Part 23, the Concessionaire or Contractor agrees that it will not discriminate against any business owner because of the owner's race, color, national origin, or sex in connection with the award or performance of any concession agreement, management contract, or subcontract, purchase or lease agreement, or other agreement covered by 49 C.F.R. Part 23. The concessionaire or Contractor agrees to include the above statements in any subsequent concession agreement or contract covered by 49 C.F.R. Part 23 that it enters into and cause those businesses to similarly include the statements in further agreements.

2.8 Miscellaneous

A. Contractor agrees that it will undertake an affirmative action plan in conformance with 14 C.F.R. Part 152, Subpart E (Nondiscrimination in Airport Aid Program), to ensure that no person shall on the grounds of race, creed, color, national origin, or sex be excluded from participating in any employment, contracting, or leasing activities covered in 14 C.F.R. Part 152, Subpart E. Contractor assures that no person will be excluded on such grounds from participating in or receiving the services or benefits of any program or activity covered by Subpart E. Contractor further agrees that it will require its covered suborganizations to provide assurances to Contractor that they similarly will undertake affirmative action programs and that they will require like assurances from their suborganizations as required by 14 C.F.R. Part 152, Subpart E.

B. City of Phoenix reserves the right to further develop, improve, repair, and alter the Airport and all roadways, parking areas, terminal facilities, landing areas, and taxiways, as it may reasonably see fit, free from any and all liability to Contractor for loss of business or damages of any nature whatsoever to Contractor occasioned during the making of such improvements, repairs, alterations, and additions.

C. The City of Phoenix reserves the right, but is not obligated to Contractor, to maintain and keep in repair the landing area of the Airport and all publicly-owned facilities of the Airport, together with the right to direct and control all activities of Contractor in this regard.

D. Contractor acknowledges that this Contract is subordinate to any existing or future agreement between the City of Phoenix and the United States concerning the development, operation, or maintenance of the Airport. If the FAA or its successors require modifications or changes in the Contract as a condition to obtaining funds for improvements at the Airport or as a requirement of any prior grants, Contractor hereby consents to any and all such modifications and changes as may be reasonably required and agrees that it will adopt any such modifications and changes as part of this Contract.

E. This Contract is subordinate to the reserved right of the City of Phoenix and its successors and assigns to occupy and use for the benefit of the public the airspace above the Premises for the right of flight for the passage of aircraft. This public right of flight includes the right to cause in the airspace any noise inherent in the operation of any aircraft through the airspace or in landing at, taking off from, or operating at an Airport.

F. Contractor agrees to comply with the notification and review requirements, as required by 14 C.F.R. Part 77 (Safe, Efficient Use, and Preservation of the Navigable Airspace), if future construction of a structure is planned for the Premises or a planned modification of a structure on the Premises. Contractor shall submit the required FAA Form 7460-1 (Notice of Proposed Construction or Alteration) and provide documentation showing compliance with the federal requirements. After the FAA has completed the aeronautical study, Contractor shall provide to the City of Phoenix the FAA determination letter on proposed construction and any impact to air navigation. Contractor covenants for itself and its successors and assigns that it will not erect or permit the erection of any structure or permit the growth of any tree on the Premises above the mean sea level elevation for (1) Phoenix Sky Harbor International Airport, 1,134 feet, (2) Phoenix Goodyear Airport, 968 feet, and (3) Phoenix Deer Valley Airport, 1,476 feet. As a remedy for the breach of the covenant, the City of Phoenix reserves the right to enter the Premises and remove the offending structure or cut the offending tree at Contractor's expense.

G. Contractor, by accepting this Contract, covenants for itself and its successors and assigns, that no use will be made of the Premises that might in any manner interfere with the landing and taking off of aircraft from the Airport or otherwise constitute a hazard to air navigation. As a remedy for the breach of the covenant, the City of Phoenix reserves the right to enter the Premises and abate the interference at Contractor's expense.

H. Contractor agrees that nothing in this Contract may be construed to grant or authorize the granting of an exclusive right within the meaning of 49 U.S.C. § 40103(e) (No exclusive rights at certain facilities).

I. This Contract is subordinate to whatever rights the United States now has or in the future may acquire affecting the control, operation, regulation, and

taking-over of the Airport or the exclusive or non-exclusive use of the Airport by the United States during a time of war or national emergency.

J. If this Contract involves construction, Contractor shall carry out the project in accordance with FAA airport design, construction, and equipment standards and specifications current on the date of project approval.

K. Contractor is encouraged to use fuel and energy conservation practices.

3. Immigration Reform and Control Act of 1986 (IRCA)

Contractor agrees that IRCA (Public Law 99-603) applies to it. Contractor shall comply with the provisions of IRCA as it applies to its activities under this Contract and to permit the City of Phoenix to inspect its personnel records to verify its compliance.

4. Conflict of Interest

Contractor agrees that the City of Phoenix may cancel this Contract pursuant to Arizona Revised Statutes (A.R.S.) § 38-511 (Cancellation of political subdivision and state contracts).

5. Legal Worker Requirements

The City is prohibited by A.R.S. § 41-4401 from awarding an agreement to any contractor who fails, or whose subcontractors fail, to comply with A.R.S. § 23-214(A) (Verification of employment eligibility; E-Verify program). Therefore, Contractor agrees that:

A. Contractor and each subcontractor it uses warrants their compliance with all federal immigration laws and regulations that relate to their employees and their compliance with § 23-214(A).

B. A breach of warranty under paragraph A above shall be deemed a material breach of this Contract and is subject to penalties up to and including termination of the Agreement.

C. The City of Phoenix retains the legal right to inspect the papers of Contractor or its subcontractor employees who work on this Contract to ensure that Contractor or its subcontractors are complying with the warranty under paragraph A above.

6. City of Phoenix Equal Employment Opportunity Requirement

6.1 If Contractor is by this Contract a supplier to or lessee of the City, then the requirements of the Phoenix City Code, Chapter 18, Article V applies, including the agreement that:

“Any supplier/lessee in performing under this contract shall not discriminate against any worker, employee or applicant, or any member of the public, because of race, color, religion, sex, national origin, age, or disability, nor otherwise commit an unfair employment practice. The supplier and/or lessee shall ensure that applicants are employed, and employees are dealt with during employment without regard to their race, color, religion, sex, national origin, age, or disability, and shall adhere to a policy to pay equal compensation to men and women who perform jobs that require substantially equal skill, effort, and responsibility, and that are performed within the same establishment under similar working conditions. Such action shall include but not be limited to the following: employment, promotion, demotion or transfer, recruitment or recruitment advertising, layoff or termination; rates of pay or other forms of compensation; and selection for training; including apprenticeship. The supplier further agrees that this clause will be incorporated in all subcontracts with all labor organizations furnishing skilled, unskilled and union labor, or who may perform any such labor or services in connection with this contract.”

Supplier/lessee further agrees that this clause will be incorporated in all subcontracts, job-consultant agreements or subleases of this agreement entered into by supplier/lessee.

If the supplier/lessee employs more than 35 employees, the following language shall be included as the last paragraph to the clause above:

“The supplier/lessee further agrees not to discriminate against any worker, employee or applicant, or any member of the public, because of sexual orientation or gender identity or expression and shall ensure that applicants are employed, and employees are dealt with during employment without regard to their sexual orientation or gender identity or expression.”

6.2 Documentation. Suppliers and lessees may be required to provide additional documentation to the Equal Opportunity Department affirming that a nondiscriminatory policy is being utilized.

6.3 Monitoring. The Equal Opportunity Department shall monitor the employment policies and practices of suppliers and lessees subject to this Section 3 as deemed necessary. The Equal Opportunity Department is authorized to conduct on-site

compliance reviews of selected firms, which may include an audit of personnel and payroll records, if necessary.

7. Title VI List of Pertinent Nondiscrimination Acts and Authorities

During the performance of this Contract, Contractor, for itself, its assignees, and successors interest (hereinafter referred to as the “Contractor”) agrees to comply with the following non-discrimination statutes and authorities; including but not limited to:

- Title VI of the Civil Rights Act of 1964 (42 USC § 2000d *et seq.*, 78 stat. 252) (prohibits discrimination on the basis of race, color, national origin);
- 49 CFR part 21 (Non-discrimination in Federally-Assisted programs of the Department of Transportation—Effectuation of Title VI of the Civil Rights Act of 1964);
- The Uniform Relocation Assistance and Real Property Acquisition Policies Act of 1970, (42 USC § 4601) (prohibits unfair treatment of persons displaced or whose property has been acquired because of Federal or Federal-aid programs and projects);
- Section 504 of the Rehabilitation Act of 1973 (29 USC § 794 *et seq.*), as amended (prohibits discrimination on the basis of disability); and 49 CFR part 27 (Nondiscrimination on the Basis of Disability in Programs or Activities Receiving Federal Financial Assistance);
- The Age Discrimination Act of 1975, as amended (42 USC § 6101 *et seq.*) (prohibits discrimination on the basis of age);
- Airport and Airway Improvement Act of 1982 (49 USC § 47123), as amended (prohibits discrimination based on race, creed, color, national origin, or sex);
- The Civil Rights Restoration Act of 1987 (PL 100-259) (broadened the scope, coverage and applicability of Title VI of the Civil Rights Act of 1964, the Age Discrimination Act of 1975 and Section 504 of the Rehabilitation Act of 1973, by expanding the definition of the terms “programs or activities” to include all of the programs or activities of the Federal-aid recipients, sub-recipients and contractors, whether such programs or activities are Federally funded or not);
- Titles II and III of the Americans with Disabilities Act of 1990 (42 USC § 12101, *et seq.*) (prohibit discrimination on the basis of disability in the operation of public entities, public and private transportation systems, places of public accommodation, and certain testing entities) as implemented by U.S. Department of Transportation regulations at 49 CFR parts 37 and 38;
- The Federal Aviation Administration’s Nondiscrimination statute (49 USC § 47123) (prohibits discrimination on the basis of race, color, national origin, and sex);

- Executive Order 12898, Federal Actions to Address Environmental Justice in Minority Populations and Low-Income Populations (ensures nondiscrimination against minority populations by discouraging programs, policies, and activities with disproportionately high and adverse human health or environmental effects on minority and low-income populations);
- Executive Order 13166, Improving Access to Services for Persons with Limited English Proficiency, and resulting agency guidance, national origin discrimination includes discrimination because of limited English proficiency (LEP). To ensure compliance with Title VI, you must take reasonable steps to ensure that LEP persons have meaningful access to your programs [70 Fed. Reg. 74087 (2005)];
- Title IX of the Education Amendments of 1972, as amended, which prohibits you from discriminating because of sex in education programs or activities (20 USC § 1681, et seq).

8. Contractor Requirements for the Mitigation of Heat-Related Illnesses and Injuries in the Workplace, Phoenix City Code Sec. 18-411

Any contractor whose employees and contract workers perform work in an outdoor environment under this contract must keep on file a written heat safety plan. The city may request a copy of this plan and documentation of all heat safety and mitigation efforts currently implemented to prevent heat-related illnesses and injuries in the workplace. The plan must also be posted where it is accessible to employees. At a minimum, the heat safety and mitigation plan and documentation required under this provision shall include each of the following as it relates to heat safety and mitigation:

- A.** Availability of sanitized cool drinking water free of charge at locations that are accessible to all employees and contract workers.
- B.** Ability to take regular and necessary breaks as needed and additional breaks for hydration.
- C.** Access to shaded areas and/or air conditioning.
- D.** Access to air conditioning in vehicles with enclosed cabs. All such vehicles must contain functioning air conditioning by no later than May 1, 2025.
- E.** Effective acclimatization practices to promote the physiological adaptations of employees or contract workers newly assigned or reassigned to work in an outside environment.
- F.** Conduct training and make it available and understandable to all employees and contract workers on heat illness and injury that focuses on the environmental and personal risk factors, prevention, how to recognize and report signs

and symptoms of heat illness and injury, how to administer appropriate first aid measures and how to report heat illness and injury to emergency medical personnel.

G. The contractor further agrees that this clause will be incorporated in all subcontracts with subcontractors, sublicensees or sublessees who may perform labor or services in connection with this contract. Additionally, the contractor agrees to require all subcontractors, sublicensees or sublessees to include this clause in all contracts with any third party who is contracted to perform labor or services in connection with this contract. It is the obligation of the contractor to ensure compliance by its subcontractors.

2438541
Revised 5/22/2024

EXHIBIT B
Design Example of Custom Signage



EXHIBIT C
4' X 8' SIGNS

ZONING HEARING

Rezoning Case No:

Zoning Change From:
Acreage:
Location:
Proposal:

To:

GRAPHICS
(If needed)

VILLAGE PLANNING COMMITTEE Village Name	PLANNING COMMISSION	IF APPEALED FROM PLANNING COMMISSION CITY COUNCIL
<hr style="border: none; border-top: 1px solid black; width: 100%;"/> <hr style="border: none; border-top: 1px solid black; width: 100%;"/>	<hr style="border: none; border-top: 1px solid black; width: 100%;"/> <hr style="border: none; border-top: 1px solid black; width: 100%;"/>	<hr style="border: none; border-top: 1px solid black; width: 100%;"/> <hr style="border: none; border-top: 1px solid black; width: 100%;"/>
LOCATION	City of Phoenix Council Chambers 200 West Jefferson Street Phoenix, AZ 85003	City of Phoenix Council Chambers 200 West Jefferson Street Phoenix, AZ 85003

PLEASE CALL TO CONFIRM INFORMATION / POR FAVOR LLAME PARA CONFIRMAR LA INFORMACIÓN (602) 262-7131 #6
 FURTHER INFORMATION AVAILABLE AT: <https://www.phoenix.gov/pddsites/pages/my-community-map.aspx>
 or at Phoenix City Hall, 200 West Washington Street, 2nd Floor - Zoning Counter, Phoenix, Arizona 85003

PLEASE CALL XXX-XXX-XXXX FOR SIGN REMOVAL



ZONING HEARING

Rezoning Case No:

Zoning Change From:
Acreage:
Location:
Proposal:

To:

GRAPHICS
(If needed)

HISTORIC PRESERVATION COMMISSION	VILLAGE PLANNING COMMITTEE Village Name	PLANNING COMMISSION	IF APPEALED FROM PLANNING COMMISSION CITY COUNCIL
<hr style="border: none; border-top: 1px solid black; width: 100%;"/> <hr style="border: none; border-top: 1px solid black; width: 100%;"/>	<hr style="border: none; border-top: 1px solid black; width: 100%;"/> <hr style="border: none; border-top: 1px solid black; width: 100%;"/>	<hr style="border: none; border-top: 1px solid black; width: 100%;"/> <hr style="border: none; border-top: 1px solid black; width: 100%;"/>	<hr style="border: none; border-top: 1px solid black; width: 100%;"/> <hr style="border: none; border-top: 1px solid black; width: 100%;"/>
LOCATION	LOCATION	City of Phoenix Council Chambers 200 West Jefferson Street Phoenix, AZ 85003	City of Phoenix Council Chambers 200 West Jefferson Street Phoenix, AZ 85003

PLEASE CALL TO CONFIRM INFORMATION / POR FAVOR LLAME PARA CONFIRMAR LA INFORMACIÓN (602) 262-7131 #6
 FURTHER INFORMATION AVAILABLE AT: <https://www.phoenix.gov/pddsites/pages/my-community-map.aspx>
 or at Phoenix City Hall, 200 West Washington Street, 2nd Floor - Zoning Counter, Phoenix, Arizona 85003

PLEASE CALL XXX-XXX-XXXX FOR SIGN REMOVAL



EXHIBIT C CONTINUED
4' X 8' SIGNS

ZONING HEARING

Rezoning Case No:

Zoning Change From:
Acreage:
Location:
Proposal:

To:



INFORMATIONAL MEETING VILLAGE PLANNING COMMITTEE Village Name	VILLAGE PLANNING COMMITTEE Village Name	PLANNING COMMISSION	IF APPEALED FROM PLANNING COMMISSION CITY COUNCIL
_____ _____	_____ _____	_____ _____	_____ _____
LOCATION	LOCATION	City of Phoenix Council Chambers 200 West Jefferson Street Phoenix, AZ 85003	City of Phoenix Council Chambers 200 West Jefferson Street Phoenix, AZ 85003

PLEASE CALL TO CONFIRM INFORMATION / POR FAVOR LLAME PARA CONFIRMAR LA INFORMACIÓN (602) 262-7131 #6
FURTHER INFORMATION AVAILABLE AT: <https://www.phoenix.gov/pddsites/pages/my-community-map.aspx>
or at Phoenix City Hall, 200 West Washington Street, 2nd Floor - Zoning Counter, Phoenix, Arizona 85003

PLEASE CALL XXX-XXX-XXXX FOR SIGN REMOVAL

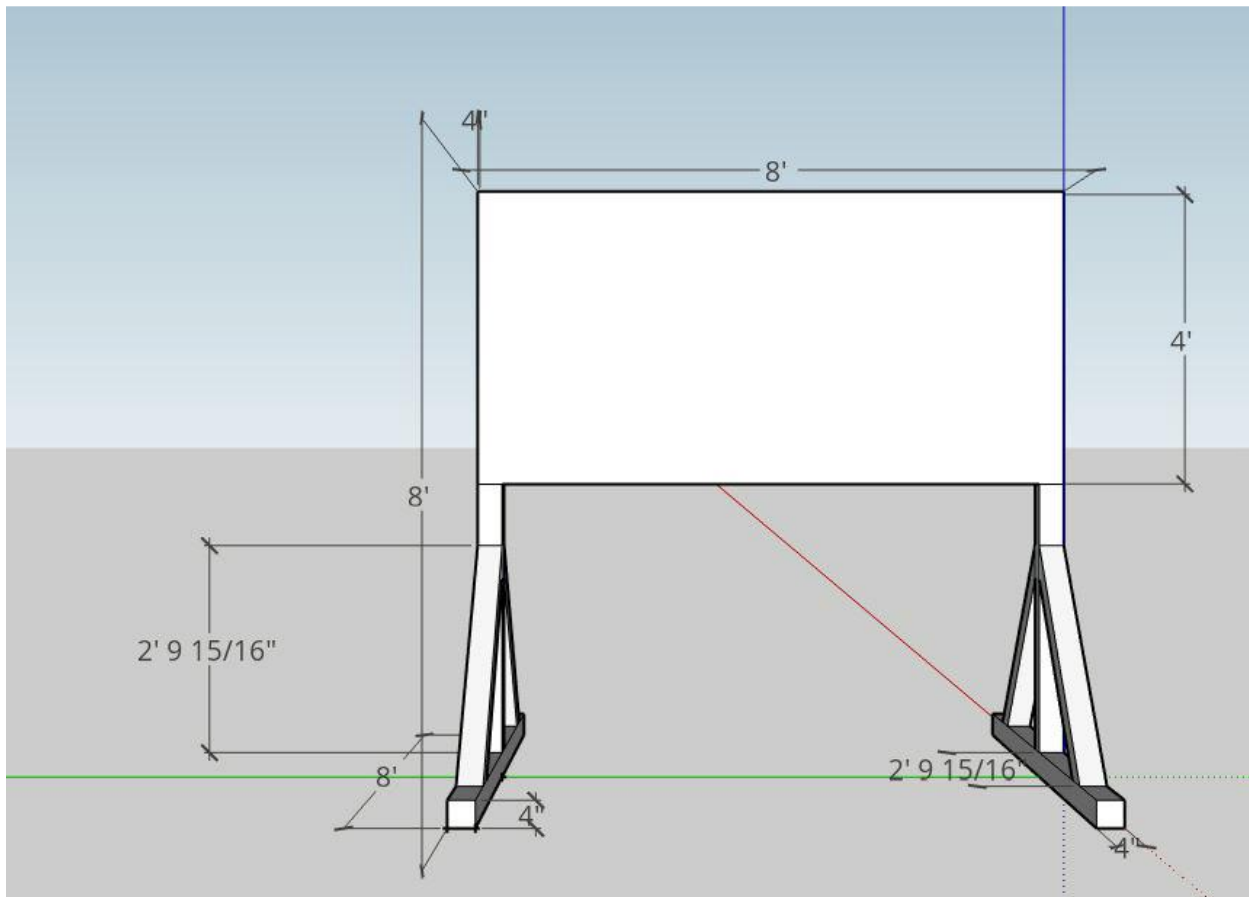

EXHIBIT D
CRADLES FOR 4' X 8' SIGNS

Two types of Cradles are shown as examples.

Cradle 1 is comprised of 4-4" x 4" x 8' wooden posts (2 upright posts and 2 skids) all sides painted white, with appropriate bracing (painted white). Cradle 1 is used primarily with 4' x 8' plywood or similar material.

CRADLE-1-F



CRADLE-1-0

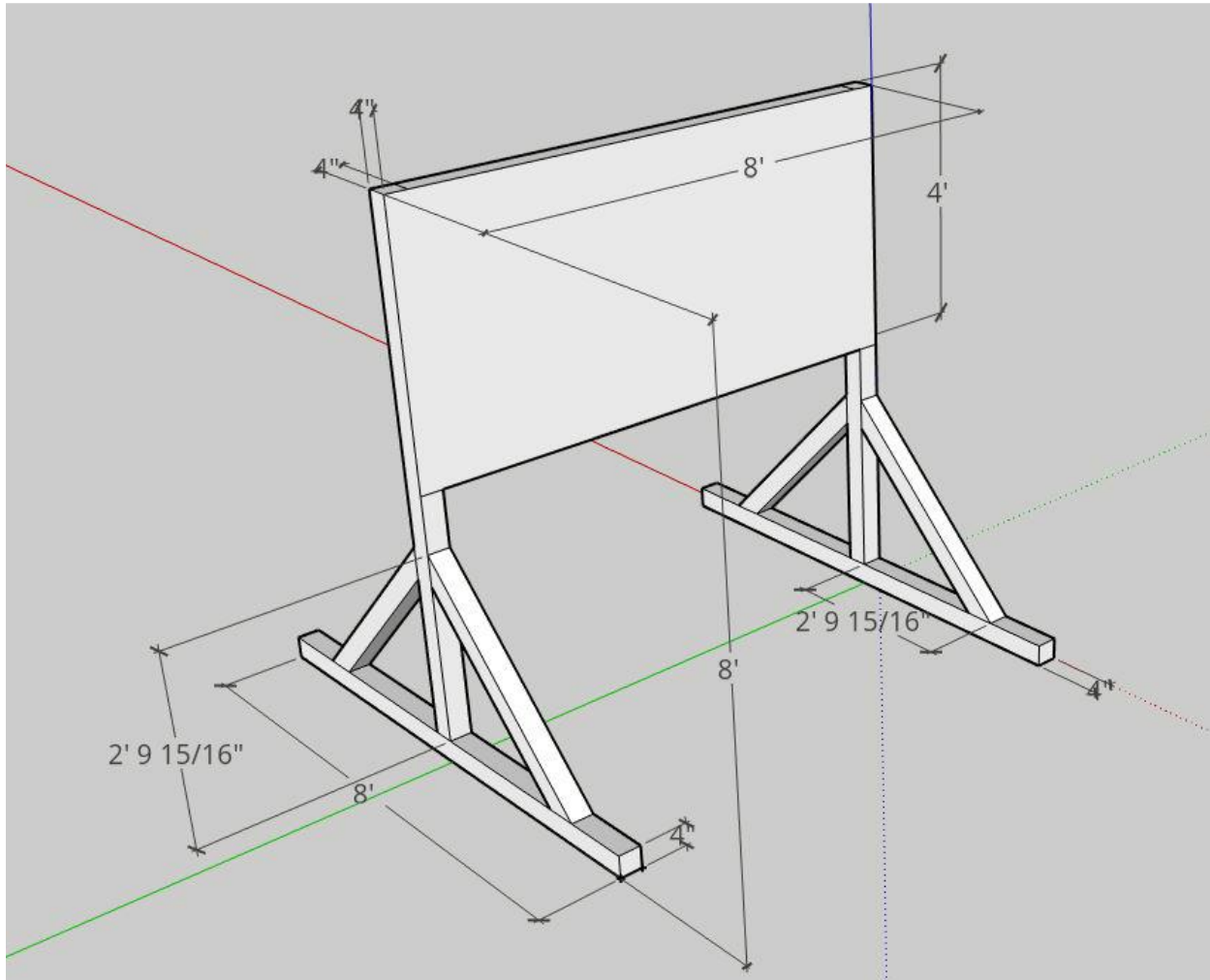
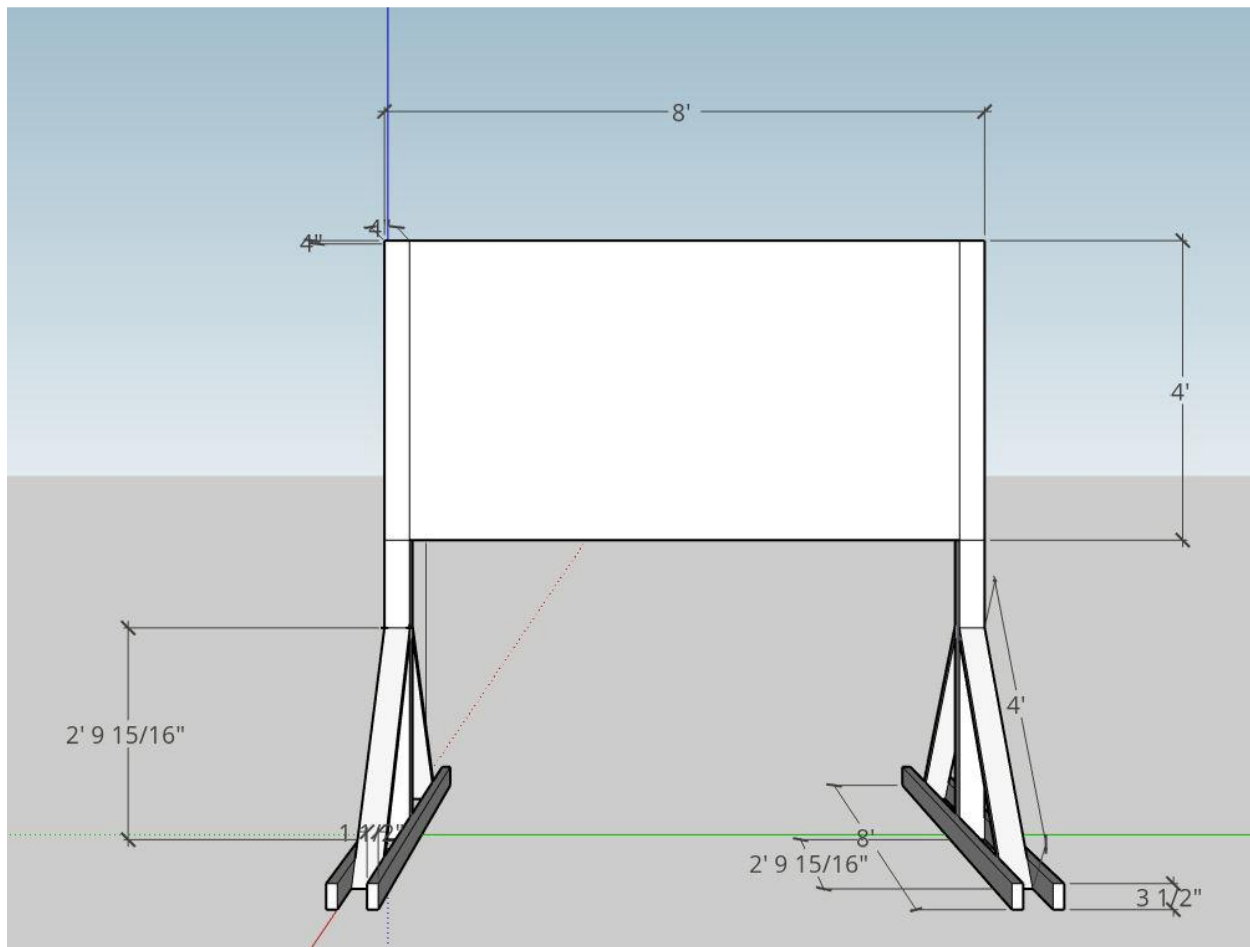

EXHIBIT D CONTINUED

Cradle 2 is comprised of 2-4" x 4" x 8' wooden posts (2 upright posts) and 4-2" x 4" x 8' wooden studs (4 skids) all sides painted white, with appropriate bracing (painted white). Cradle 2 used primarily with 4' x 8' White 10 Mil Coroplast material.

CRADLE-2-F



CRADLE-2-S

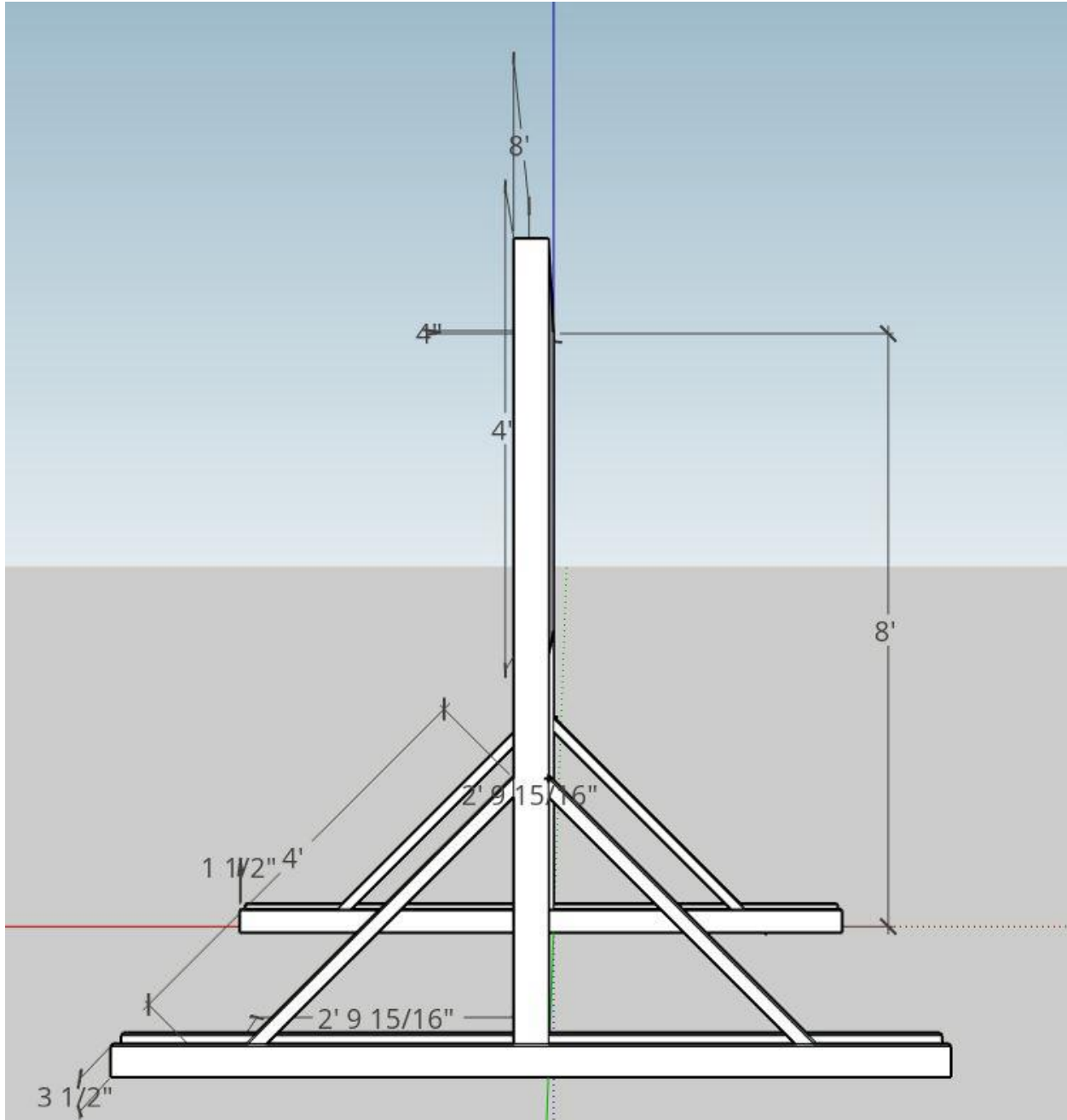

EXHIBIT E
NOTICE OF POSTING

NOTICE OF POSTING(s) for:
12/5/2024
ZONING ADJUSTMENT HEARING

Date Posted	Case Number	Address or location
mm/dd/yyyy	ZA-36-13-7	2836 South 49th Avenue
mm/dd/yyyy	ZA-70-13-7	2111 West McDowell Road
mm/dd/yyyy	ZA-564-19-3	12401 North Cave Creek Road
mm/dd/yyyy	ZA-707-24-4	4301 North 7th Avenue
mm/dd/yyyy	ZA-730-24-1	4626 West Tonopah Road
mm/dd/yyyy	ZA-765-24-8	1627 East Wood Street
mm/dd/yyyy	ZA-751-24-2	13802 North Scottsdale Road, Suite 161
mm/dd/yyyy	ZA-774-24-8	6713 South 40th Avenue

I certify that I have posted a notice for the hearing / cases listed above:

(SIGNATURE / DATE)

EXHIBIT E CONTINUED



EXHIBIT F
HEARING SIGNS

ZONING ADJUSTMENT

HEARING DATE / TIME:

**December 5, 2024
1:30 PM**

LOCATION:

**200 West Washington Street,
1st Floor, Assembly Room C
Phoenix, AZ 85003**

To participate, see the instructions on the agenda
available on the Public Meeting Notices website:

<https://www.phoenix.gov/cityclerk/publicmeetings/notices>



CASE # ZA-36-13-7

2836 South 49th Avenue

**1 YEAR REVIEW OF
USE PERMIT:**

- 1) Use permit to allow a
Medical Marijuana
Cultivation Facility.**

- 2) Use permit to allow a
Medical Marijuana
Infusion Production
Facility.**

Unlawful removal or destruction of this sign is punishable by law

EXHIBIT G
HISTORIC PRESERVATION BLUE HISTORIC DISTRICT SIGN

Cutting Diagram – Sign Blank

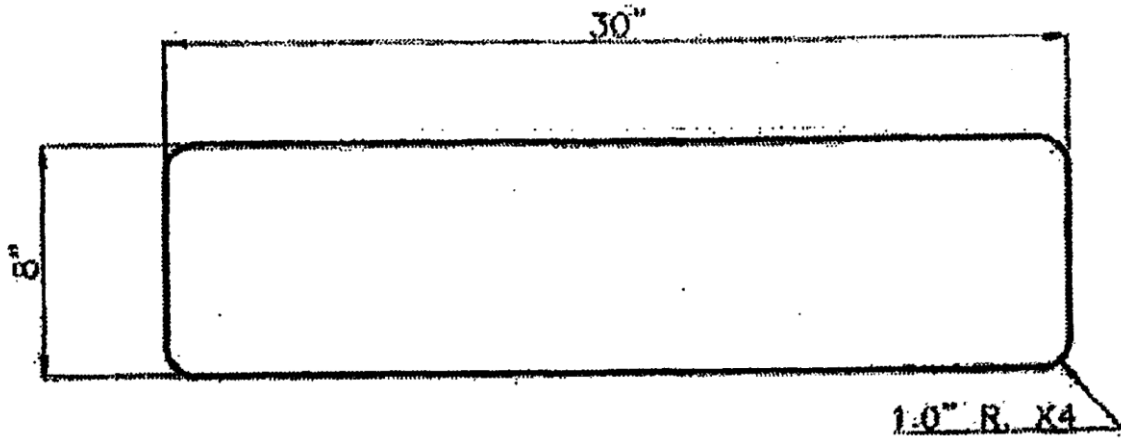

Metro-Wing Bracket

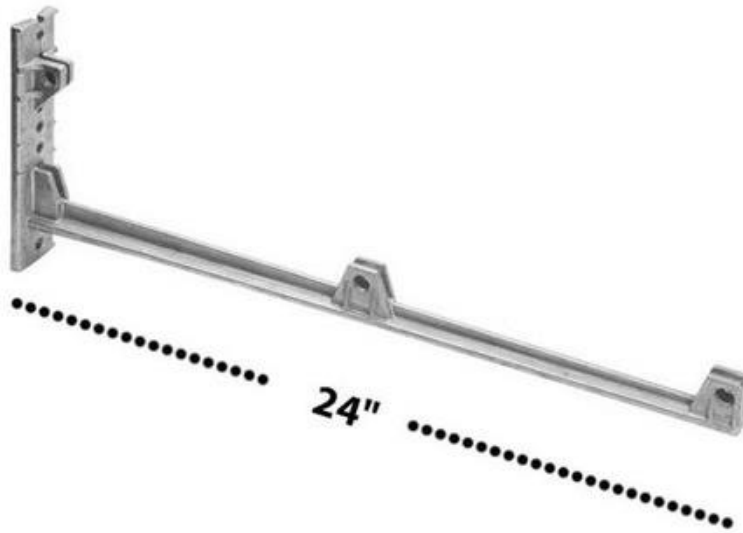

EXHIBIT G CONTINUED
HISTORIC PRESERVATION BLUE HISTORIC DISTRICT SIGN

Example of Installed Sign



EXHIBIT H
HISTORIC PRESERVATION GRANT SIGN

24" X 24" Coroplast sign



EXHIBIT I
HISTORIC PRESERVATION ALUMINUM PLAQUES

SIZE: 12" X 8"



■ - Raised
■ - Recessed

Times New Roman Bold Font
Top 2 lines: 61 PT font, 1 PT stroke
Lower lines: 32 PT font, 1.5 PT stroke
Phoenix bird: 1" x 1"
House logo: 1.83" wide x 1" tall

(note: language will vary depending on whether property is listed on
Phoenix Historic Property Register, National Register of Historic Places, or both)

EXHIBIT I CONTINUED
HISTORIC PRESERVATION ALUMINUM PLAQUES

Example of Installed Plaque

