



City of Phoenix

INVITATION FOR BID  
IFB 25-SWCES-032  
300 GALLON REFUSE CONTAINERS

City of Phoenix  
Public Works  
200 West Washington Street, 7th Floor  
Phoenix, AZ 85003

RELEASE DATE: January 21, 2025

DEADLINE FOR QUESTIONS: February 12, 2025, 11:00am

RESPONSE DEADLINE: February 19, 2025, 11:00am

City of Phoenix  
INVITATION FOR BID  
IFB 25-SWCES-032  
300 Gallon Refuse Containers

1. INTRODUCTION .....	3
2. INSTRUCTIONS .....	5
3. SCOPE OF WORK .....	13
4. STANDARD TERMS AND CONDITIONS .....	18
5. SPECIAL TERMS AND CONDITIONS.....	32
6. DEFENSE AND INDEMNIFICATION .....	36
7. INSURANCE REQUIREMENTS .....	37
8. SUBMITTALS .....	40
9. EXHIBIT A - SIDE DIMENSIONS.....	42
EXHIBIT B - FRONT DIMENSIONS.....	44
EXHIBIT C - BIN CONTAINER PICTURES.....	45

Attachments and Submittal Forms:

Attachment - IFB-25-SWCES-032 - Pricing Schedule (Attached Separately)

Submittals - 24 Hour Emergency Contact

Submittals - Conflict of Interest and Transparency

Submittals - Costs and Payments

Submittals - Offer Page

# 1. Introduction

## 1.1. Summary

The City of Phoenix seeks to establish a contract or contracts for the purchase of 300-gallon refuse containers, on an as-needed basis, as specified in the scope of work.

## 1.2. Contact Information

**Alejandro Rozenberg**  
Contracts Specialist II  
200 West Washington Street, 7th Floor  
Phoenix, AZ 85003  
Email: [alejandro.rozenberg@phoenix.gov](mailto:alejandro.rozenberg@phoenix.gov)  
Phone: [\(602\) 534-0095](tel:(602)534-0095)

**Department:**  
Public Works

## 1.3. Timeline

### Schedule of Events

The City reserves the right to change dates, times, and locations, as necessary. All times are Phoenix local time. The City does not always hold a Pre-Offer Conference or Site Visit.

To request a reasonable accommodation or alternative format for any public meeting, please contact the Procurement Officer (Sean Wulfekule) at (602) 534-0095/Voice or 711/TTY, or [sean.wulfekuhle@phoenix.gov](mailto:sean.wulfekuhle@phoenix.gov), no later than two (2) weeks prior to the meeting.

<b>Solicitation Issue Date</b>	<b>January 21, 2025, Phoenix Time</b>
<b>Pre-Offer Conference (Non-Mandatory)</b>	<b>February 5, 2025, 9:00am Phoenix Time</b> Via Microsoft TEAMS <a href="https://teams.microsoft.com/join/19%3ameeting_NDIwNGM5YTMtYjc4NC00ZDQ2LWE2ZGQtNjFiYTU4MWU1ZWZmZ%40tHread.v2/0?context=%7b%22Tid%22%3a%2296b9695c-4f0e-42bd-8adf-ba755760346b%22%2c%22Oid%22%3a%22129e91dc-0bfe-4458-8b6b-7e8f1092b27d%22%7d">https://teams.microsoft.com/join/19%3ameeting_NDIwNGM5YTMtYjc4NC00ZDQ2LWE2ZGQtNjFiYTU4MWU1ZWZmZ%40tHread.v2/0?context=%7b%22Tid%22%3a%2296b9695c-4f0e-42bd-8adf-ba755760346b%22%2c%22Oid%22%3a%22129e91dc-0bfe-4458-8b6b-7e8f1092b27d%22%7d</a>

<p><b>Written Inquiries Due Date</b></p>	<p><b>February 12, 2025, 11:00am Phoenix Time</b></p> <p>Submit all written inquiries to: <a href="mailto:alejandro.rozenberg@phoenix.gov">alejandro.rozenberg@phoenix.gov</a></p>
<p><b>Offer Due Date</b></p>	<p><b>February 19, 2025, 11:00am Phoenix Time</b></p> <p>(See paragraph 2.12, Submission of Offer, for instructions)</p> <p>PWD Procurement Bid Opening Meeting Join from the meeting link</p> <p>Via WEBEX</p> <p><a href="https://phxpublicworks.webex.com/phxpublicworks/j.php?MTID=m22d7639c2f76d49e34eb79c38fd1aecf">https://phxpublicworks.webex.com/phxpublicworks/j.php?MTID=m22d7639c2f76d49e34eb79c38fd1aecf</a></p> <p>Join by meeting number Meeting number (access code): 2485 824 7099 Meeting password: aFvw9qmuc22</p> <p>Tap to join from a mobile device (attendees only) +1-415-655-0001,,24858247099## US Toll</p>
<p><b>Offer Submittal Location</b></p>	<p>Electronically to: <a href="mailto:pwd.solicitations@phoenix.gov">pwd.solicitations@phoenix.gov</a></p> <p><b>OR</b></p> <p>In person to:</p> <p>City of Phoenix</p> <p>Public Works Department 200 W. Washington St, 1<sup>st</sup> floor atrium Phoenix, AZ 85003 Atrium is just beyond the security checkpoint. The drop-off box is a grey bin marked Public Works Department.</p>

## 2. Instructions

### 2.1. Description – Statement of Need

The City of Phoenix invites sealed offers for 300 Gallon Refuse Containers for a three-year term, with two option years commencing on or about June 1, 2025, in accordance with the specifications and provisions contained herein or the “Effective Date” which is upon award by City Council, conditioned upon signature and recording by the City Clerk’s department, as required by the Phoenix City Code, whichever is later.

This solicitation is available through Arizona Relay Service 7-1-1. Please call TTY 800-367-8939 for assistance.

Notwithstanding the foregoing, this Agreement will terminate upon the earliest occurrence: by reaching the end of the term including any extensions exercised, or termination pursuant to the provisions of this Agreement.

### 2.2. City's Vendor Self-Registration and Notification

Vendors must be registered in the City’s procurePHX Self-Registration System at <https://www.phoenix.gov/procure> to respond to solicitations and access procurement information. The City may, at its sole discretion, reject any offer from an Offeror who has not registered.

### 2.3. Preparation of Offer

All forms provided in Submittal Section must be completed and submitted with the Offer. The signed and completed Conflict of Interest and Transparency form must be included or your Offer may be deemed non-responsive.

It is permissible to copy Submittal forms if necessary. Erasures, interlineations, or other modifications of the Offer must be initialed in original ink by the authorized person signing the Offer. No offer will be altered, amended or withdrawn after the specified offer due date and time. The City is not responsible for Offeror’s errors or omissions.

All time periods stated as a number of days will be calendar days.

It is the responsibility of all Offerors to examine the entire solicitation and seek clarification of any requirement that may not be clear and to check all responses for accuracy before submitting an offer. Negligence in preparing an offer confers no right of withdrawal after due date and time. Offerors are strongly encouraged to:

- A. Consider applicable laws and/or economic conditions that may affect cost, progress, performance, or furnishing of the products or services.
- B. Study and carefully correlate Offeror’s knowledge and observations with the solicitation and other related data.
- C. Promptly notify the City of all conflicts, errors, ambiguities, or discrepancies that Offeror has discovered in or between the solicitation and other related documents.
- D. The City does not reimburse the cost of developing, presenting or providing any response to this solicitation. Offers submitted for consideration should be prepared simply and

economically, providing adequate information in a straightforward and concise manner. The Offeror is responsible for all costs incurred in responding to this solicitation. All materials and documents submitted in response to this solicitation become the property of the City and will not be returned.

- E. Offerors are reminded that the specifications stated in the solicitation are the minimum level required and that offers submitted must be for products or services that meet or exceed the minimum level of all features specifically listed in this solicitation. Offers offering less than any minimum specifications or criteria specified are not responsive and should not be submitted.
- F. Offer responses submitted for products considered by the seller to be acceptable alternates to the brand names or manufacturer's catalog references specified herein must be submitted with technical literature and/or detailed product brochures for the City's use to evaluate the products offered. Offers submitted without this product information may be considered as non-responsive and rejected. The City will be the sole judge as to the acceptability of alternate products offered.
- G. Prices will be submitted on a per unit basis by line item, when applicable. In the event of a disparity between the unit price and extended price, the unit price will prevail unless obviously in error.

## 2.4. Fixed Offer Price Period

All offers shall be firm and fixed for a period of 180 calendar days from the solicitation opening date.

## 2.5. Obtaining a Copy of the Solicitation and Addenda

Interested Offerors may download the complete solicitation and addenda from <https://solicitations.phoenix.gov/>. Any interested Offerors without internet access may obtain this solicitation by calling the Procurement Officer or picking up a copy during regular business hours at the City of Phoenix, Public Works Department, 200 W. Washington Street, 7th Floor, Phoenix, AZ 85003. It is the Offeror's responsibility to check the website, read the entire solicitation, and verify all required information is submitted with their Offer.

## 2.6. Exceptions

Offeror must not take any exceptions to any terms, conditions or material requirements of this solicitation. Offers submitted with exceptions may be deemed non-responsive and disqualified from further consideration in the City's sole discretion. Offerors must conform to all the requirements specified in the solicitation. The City encourages Offerors to send inquiries to the Procurement Officer rather than including exceptions in their Offer.

## 2.7. Inquiries

All questions that arise relating to this solicitation should be directed via email to the Procurement Officer and must be received by the due date indicated in the Schedule of Events. The City will not consider questions received after the deadline.

No informal contact initiated by Offerors on the proposed service will be allowed with members of City's staff from date of distribution of this solicitation until after city council awards the contract. All questions concerning or issues related to this solicitation must be presented in writing.

The Procurement Officer will answer written inquiries in an addendum and publish any addendums on the Procurement Website.

## 2.8. Addenda

The City of Phoenix will not be responsible for any oral instructions made by any employees or officers of the City of Phoenix regarding this solicitation. Any changes will be in the form of an addendum. The Offeror must acknowledge receipt of any/all addenda by signing and returning the document with the Offer submittal.

## 2.9. Business in Arizona

The City will not enter contracts with Offerors (or any company(ies)) not granted authority to transact business, or not in good standing, in the state of Arizona by the Arizona Corporation Commission, unless the Offeror asserts a statutory exception prior to entering a contract with the City.

## 2.10. Licenses

If required by law for the operation of the business or work related to this Offer, Offeror must possess all valid certifications and/or licenses as required by federal, state or local laws at the time of submittal.

## 2.11. Certifications

By signature in the Offer section of the Offer and Acceptance page(s), Offeror certifies:

- The submission of the Offer did not involve collusion or other anti-competitive practices.
- The Offeror must not discriminate against any employee, or applicant for employment in violation of Federal or State Law.
- The Offeror has not given, offered to give, nor intends to give at any time hereafter, any economic opportunity, future employment, gift, loan, gratuity, special discount, trip, favor, or service to a public servant in connection with the submitted Offer.

## 2.12. Submission of Offer

Offers must be in possession of the Department on or prior to the exact time and date indicated in the Schedule of Events. Late offers will not be considered. The prevailing clock will be the City Department's clock.

The City of Phoenix Public Works Department is accepting electronic Offers for this solicitation, in addition to other methods of submitting sealed Offer packages (hardcopy). Offerors are responsible for submitting the Offer (electronic or hardcopy) before the due date and time of the solicitation deadline.

The Offeror is responsible for managing potential delays due to delays caused by the Carrier or technical difficulties.

**For Electronic Submittal:** Please submit your response via email to City of Phoenix, Public Works Department, 200 W. Washington Street, 7th Floor, Phoenix, AZ 85003 OR [pwd.solicitations@phoenix.gov](mailto:pwd.solicitations@phoenix.gov). The date and time on the email will provide proof of submission and verification if the Offer was received on or prior to the due date and time specified. **Please identify the solicitation number and title in the subject line of the email when submitting the Offer.**

The City email file size is limited to 150mb. To send larger files electronically, the upload and receipt time may take longer than expected. It is the responsibility of the Offeror to ensure that the Offer met the due date and time.

**Please DO NOT submit links to Google Docs, Dropbox Paper, or similar services. Your offer may be deemed non-responsive if your offer is supplied utilizing these services.**

**For In-Person and Carrier Delivery:** Offers will be received at City of Phoenix City Hall located at 200 W. Washington St, 1st floor, Atrium, Phoenix, AZ 85003. The Atrium is just beyond the security checkpoint. The drop-off box is a grey bin marked Public Works Department. Delivery must be made during normal business hours (8:00 am – 5:00 pm, local Phoenix time, Monday – Friday) before the solicitation due date and time. Offers must be clearly marked on the outside of the package as designated in the solicitation.

**Delivery of Offers:** If the Offeror submits the Offer in a hardcopy format, then the Offer must be submitted in a sealed package/envelope marked with the following information:

- Offeror's Name
- Offeror's Address (as shown on the Certification Page)
- Solicitation Number
- Solicitation Title
- Offer Due Date

## 2.13. Withdrawal of Offer

At any time prior to the solicitation due date and time, an Offeror (or designated representative) may withdraw the Offer by submitting a request in writing and signed by a duly authorized representative. If Offeror withdraws the Offer electronically by email to the Procurement Officer, the request to withdraw must be in the form of a letter attached to the email that includes either an image of the duly authorized representative's signature or an electronic signature from a verifiable source, such as Adobe Sign, DocuSign or a similar verifiable software program.

## 2.14. Offer Results

Offers will be opened on the offer due date, time and location indicated in the Schedule of Events, at which time the name of each Offeror, and the prices may be read. Offers and other information received in response to the solicitation will be shown only to authorized City personnel having a legitimate interest in them or persons assisting the City in the evaluation. Offers are not available



for public inspection until after the City has posted the award recommendation on the City's website.

The City will post a preliminary offer tabulation on the City's website, <https://solicitations.phoenix.gov/Awards> within five business days of the offer opening. The City will post the information on the preliminary tabulation as it was read during the offer opening. The City makes no guarantee as to the accuracy of any information on the preliminary tabulation. Once the City has evaluated the offers, the City will post an award recommendation on the website. By signing and submitting its Offer, each Offeror agrees that this posting of the award recommendation to the City's website effectively serves as the Offeror's receipt of that notice of award recommendation. The City has no obligation to provide any further notification to unsuccessful Offerors.

## 2.15. Pre-Award Qualifications

Offeror must have been in operation a minimum of 2 years. The Offeror's normal business activity during the past 2 years will have been for providing the goods or services in this solicitation.

Upon notification of an intent to award, the Offeror will have ten calendar days to submit a complete certificate of insurance in the minimum amounts and the coverages as required in the Insurance Requirements of this agreement. Insurance requirements are non-negotiable.

## 2.16. Award of Contract

Unless otherwise indicated, award(s) will be made to the most responsive, responsible Offeror(s) who are regularly established in the service, or providing the goods, contained in this solicitation and who have demonstrated the ability to perform in an acceptable manner.

### A. Factors that may be considered by the City include:

1. Technical capability of the Offeror to accomplish the scope of work required in the Solicitation. This may include performance history on past and current government or industrial contracts; and,
2. Demonstrated availability of the necessary manpower (both supervisory and operational personnel) and necessary equipment to accomplish the scope of work in the Solicitation; and,
3. Safety record; and,
4. Offeror history of complaints and termination for convenience or cause.

### B. Notwithstanding any other provision of this solicitation, the City reserves the right to: (1) waive any immaterial defect or informality; or (2) reject any or all offers or portions thereof; or (3) reissue a solicitation.

### C. A response to a solicitation is an offer to contract with the City based upon the terms, conditions, and specifications contained in the City's solicitation. Offers do not become contracts until they are executed by the Chief Procurement Officer or Department Director. A contract has its inception in the award, eliminating a formal signing of a separate

contract. For that reason, all of the terms, conditions and specifications of the procurement contract are contained in the solicitation, and in any addendum or contract amendment.

## 2.17. Solicitation Transparency Policy

Commencing on the date and time a solicitation is published, potential or actual Offerors or respondents (including their representatives) shall only discuss matters associated with the solicitation with the Mayor, any members of City Council, the City Manager, any Deputy City Manager, or any department director directly associated with the solicitation (including in each case their assigned staff, except for the designated Procurement Officer) at a public meeting, posted under Arizona Statutes, until the resulting contract(s) are awarded to all offers or responses are rejected and the solicitation is cancelled without any announcement by the Procurement Officer of the City's intent to reissue the same or similar solicitation.

As long as the solicitation is not discussed, Offerors may continue to conduct business with the City and discuss business that is unrelated to the solicitation with the City staff. Offerors may not discuss the solicitation with any City employees or evaluation panel members.

Offerors may discuss their proposal or the solicitation with the Mayor or one or more members of the Phoenix City Council, provided such meetings are scheduled through the Procurement Officer, and are posted as open meetings with the City Clerk at least 24 hours prior to the scheduled meetings. The City Clerk will be responsible for posting the meetings. The posted notice shall identify the participants and the subject matter, as well as invite the public to participate.

With respect to the selection of the successful Offerors, the City Manager and/or City Manager's Office will continue the past practice of exerting no undue influence on the process. In all solicitations of bids and proposals, any direction on the selection from the City Manager and/or City Manager's Office and Department Head (or representative) to the proposal review panel or selecting authority must be provided in writing to all prospective Offerors.

This policy is intended to create a level playing field for all Offerors, assure that contracts are awarded in public, and protect the integrity of the selection process. OFFERORS THAT VIOLATE THIS POLICY SHALL BE DISQUALIFIED. After official Notice is received by the City for disqualification, the Offeror may follow the Protest process, unless the Solicitation is cancelled without notice of intent to re-issue.

"To discuss" means any contact by the Offeror, regardless of whether the City responds to the contact. Offerors that violate this policy will be disqualified until the resulting contract(s) are awarded, or all offers or responses are rejected and the solicitation is cancelled without any announcement by the Procurement Officer of the City's intent to reissue the same or a similar solicitation. The City interprets the policy as continuing through a cancellation of a solicitation until Council award of the contract, as long as the City cancels with a statement that the City will rebid the solicitation.

## 2.18. Protest Process

Offeror may protest the contents of a solicitation no later than seven days before the solicitation deadline when the protest is based on an apparent alleged mistake, impropriety or defect in the solicitation. Protests filed regarding the solicitation may be addressed by an amendment to the solicitation or denied by the City. If denied, the opening and award will proceed unless the City

determines that it is in the City's best interests to set new deadlines, amend the solicitation, cancel or re-bid.

Therefore, unless otherwise notified by a formal amendment, the Protester must adhere to all solicitation dates and deadlines, including timely filing of an offer, regardless of filing a protest.

Offeror may protest an adverse determination issued by the City regarding responsibility and responsiveness, within seven days of the date the Offeror was notified of the adverse determination.

Offeror may protest an award recommendation if the Offeror can establish that it had a substantial chance of being awarded the contract and will be harmed by the recommended award. The City will post recommendations on the City's website to award the contract(s) to an Offeror(s). Offeror must submit award protests within seven days after the posting of the award recommendation, with exceptions only for good cause shown, within the City's full and final discretion.

All protests will be in writing, filed with the Procurement Officer identified in the solicitation and include the following:

- Identification of the solicitation number;
- The name, address and telephone number of the protester;
- A detailed statement describing the legal and factual grounds for the protest, including copies of relevant documents;
- The form of relief requested; and
- The signature of the protester or its authorized representative.

The Procurement Officer will render a written decision within a reasonable period after the protest is filed. The City will not request City Council authorization to award the contract until the protest process is complete. All protests and appeals must be submitted in accordance with the City's Procurement Code, (Phoenix City Code, Ch. 43) and any protests or appeals not submitted within the time requirements will not be considered. Protests must be filed with the Procurement Officer.

## 2.19. Public Record

All Offers submitted in response to this solicitation will become the property of the City and become a matter of public record available for review pursuant to Arizona State law. If an Offeror believes that a specific section of its Offer response is confidential, the Offeror will isolate the pages marked confidential in a specific and clearly labeled section of its Offer response. An Offeror may request specific information contained within its Offer is treated by the Procurement Officer as confidential provided the Offeror clearly labels the information "confidential." To the extent necessary for the evaluation process, information marked as "confidential" will not be treated as confidential. Once the procurement file becomes available for public inspection, the Procurement Officer will not make any information identified by the Offerors as "confidential" available to the public unless necessary to support the evaluation process or if specifically requested in accordance with applicable public records law. When a public records request for such information is received, the Procurement Officer will notify the Offeror in writing of any request to view any portion of its Offer marked "confidential." The Offeror will have the time set

forth in the notice to obtain a court order enjoining such disclosure. If the Offeror does not provide the Procurement Officer with a court order enjoining release of the information during the designated time, the Procurement Officer will make the information requested available for inspection.

## 2.20. Late Offers

Late Offers must be rejected, except for good cause. If a late Offer is submitted, the Department will document the date and time of the submittal of the late Offer, keep the Offer and notify the Offeror that its Offer was disqualified for being a late Offer.

## 2.21. Right to Disqualify

The City reserves the right to disqualify any Offeror who fails to provide information or data requested or who provides materially inaccurate or misleading information or data. The City further reserves the right to disqualify any Offeror on the basis of any real or apparent conflict of interest that is disclosed by the Offer submitted or any other data or information available to the City. This disqualification is at the sole discretion of the City. By submission of a solicitation response, the Offeror waives any right to object now or at any future time, before any agency or body including, but not limited to, the City Council of the City or any court as to the exercise by the City of such right to disqualify or as to any disqualification by reason of real or apparent conflict of interest determined by the City. The City reserves the right to replace the disqualified Offeror.

## 2.22. Contract Award

In accordance with the City of Phoenix Code, Chapter 43, Section 43-12, Competitive Sealed Bidding, award(s) shall be made to the lowest responsible and responsive offeror(s) whose offer conforms in all material respects to the requirements set forth in this solicitation. The City reserves the right to award a contract by individual line items, by group, all or none, or any other combination most advantageous to the City. The City reserves the right to multiple award.

## 2.23. Determining Responsiveness and Responsibility

Offers will be reviewed for documentation of any required minimum qualifications, and completeness and compliance with the solicitation requirements. The City reserves sole discretion to determine responsiveness and responsibility.

**Responsiveness:** Nonresponsive Offers will not be considered in the evaluation process. The solicitation states criteria that determine responsiveness, and the solicitation includes terms and conditions that if included or excluded from Offers will render an Offer nonresponsive.

**Responsibility:** To obtain true economy, the City must conduct solicitations to minimize the possibility of a subsequent default by the Offeror, late deliveries, or other unsatisfactory performance that may result in additional administrative costs. It is important that the Offeror be a responsible Offeror. Responsibility includes the Offeror's integrity, skill, capacity, experience, and facilities for conducting the work to be performed.

### 3. Scope of Work

#### 3.1. Scope of Work

- A. Contractor will supply the City with 300-gallon refuse containers, on an as-needed basis, as specified herein.

#### 3.2. City Department Contract Representative (CDCR)

- A. The City Department Contract Representative(s) (CDCR) are the City employee(s) who have specifically been designated to act as a contact person or persons to the Contractor, and responsible for monitoring and overseeing the Contractor's performance under this contract.

#### 3.3. Estimated Quantities

- A. Orders are contingent upon the City's refuse and recycling collection program, which includes replacement of existing containers, lids in use and new containers for service area growth.
- B. The corresponding container requirements may be extended and/or interrupted due to conditions outside the control of the City. The City reserves the right to change the estimated container quantity as needed. Contractor will provide pricing based on the following estimated annual quantities.

Item No.	Product Description	Estimated Annual Quantities
1.	Refuse Containers - Black bodies without lids	750
2.	Refuse Lids, Black	1,500
3.	Recycling Lids, Blue	450

#### 3.4. Inspection and Acceptance

- A. Containers will be delivered to City property unassembled. Contractor will provide hardware for the containers to be assembled by the Contractor. Container lids shall be delivered to City property assembled. Contractor is required to unload the containers at the location in the service center as directed by City staff.

#### 3.5. Design Specifications

- A. **Resin Weight** - Containers and lids will be rotationally molded of high density polyethylene (HDPE) or medium density polyethylene (MDPE). Polyethylene will be produced by a recognized leading manufacturer. Material will be durable enough to last for five (5) years of outdoor, unsheltered use under Phoenix weather conditions. The finished unit (body and lid) will be minimum 85 pounds, or 0.17-inch wall thickness throughout container. Resin weight excludes hardware.

- B. **Lid** - The lid will be configured so it will not warp, bend, slump or distort to such an extent that it no longer fits flush on the bin properly or becomes otherwise unserviceable. The lid will fit flush around all contact points with the base of the bin to within the current definitions of a fly-tight as determined by Maricopa County and the City. The lid will open easily and fully to 110 degrees and remain open without assistance.
- C. **Metal Components** - All metal components will be galvanized steel or stainless and rust resistant.
- D. **Finish** - Containers, lids and all areas handled will be completely deburred with no sharp edges or corners. Interior surfaces will have a high gloss finish.
- E. **Graphics** - All graphics will be hot stamped in white. Guidelines are available in the table below.

GRAPHICS (All Containers)	LOCATION		TYPE/ SIZE	
	BIN	LID		
	Right and Left sides	Ten (10 inches) below <u>the bin lip</u>	Centered	Three (3) inches
CITY OF PHOENIX		Half inch (1/2) below the "Bird" symbol	None	One and one half (1 1/2) inches
602-262-6251 <a href="http://phoenix.gov/publicworks">phoenix.gov/publicworks</a>	Right and Left sides		Centered, one half inch below the "COP" symbol	One and one half (1 1/2) inches
DO NOT MOVE OR TURN	Right and Left sides		<u>Centered,</u> one half inch (1/2) below phone number/Web Site	One (1) inch
DO NOT BLOCK				One half (1/2) inch
BLOCKING VIOLATES CITY CODE				

- F. **Serial Number** - All containers will be hot stamped with a serial number on the upper left corner of the container body. The serial number will identify the month and year of the date each container is manufactured and the month and year of each of the container's five (5) years warranty expiration. The serial number will be white and no smaller than one-half inch (See Exhibits A, B, and C).
- G. **RFID Barcode** - All containers will be hot stamped with a bar code on the upper left corner of the container and placed directly under the serial number. A digital copy of the RFID

manifest is required to be included with each load. The list will be used to track container assets and warranties (See Exhibits A, B, and C).

- H. **Recycled Resin** - The City of Phoenix favors environmentally friendly products. Recycled post-consumer resin may be used upon approval of the City.
- I. **Color Pigmentation** - Color pigment will be hot melt compounded into the resin. Dry mixing and dry blending of pigments is not acceptable. Contractor will submit color chips prior to the City approving a specific color for each container collection type. If Contractor offers several shades, the City will select the shade.
- J. **Stabilizer** - Resin will contain an ultraviolet stabilizer, consisting of a minimum of Additive Type of one-half (1/2) of one percent (1%). The stabilizer must be hot melt compounded into the resin.
- K. **Dimension** - All dimensions must be compatible with the City's refuse and recycling collection program (See Exhibits A, B, and C).

### 3.6. Warranty

#### A. Containers, Components Parts, and Plastic Lids

1. All containers and lids (products) will have a minimum of five (5) full years warranty for normal use against workmanship and material. Lids will be fully (100%) warranted for a period of five (5) years against defects, including but not limited to cracking, peeling, distortion, failures at attachment point for lids or hinges, weathering degradation, defective or insufficient material, poor material workmanship on the part of the manufacturer, and lowered ultraviolet resistance to aging in the process of normal operational use,

#### B. Claim Procedures and Required Delivery Schedule

1. In the event that products under warranty are identified by the City as requiring replacement, the City will retain the products and notify the Contractor in writing through electronic mail (e-mail) of its warranty claim on a regular basis. Within forty-five (45) calendar days of this notification, the Contractor will honor the warranty claims by delivering replacement products to the City, Contractor may contest the City's warranty claims in writing within the 45-day period; the contest of warranty claims will not relieve the Contractor of the obligation to deliver replacement products. It will be the responsibility of the Contractor to schedule a visit with the CDCR to visually inspect the failed container(s) during the above period. Failure to inspect any failed products will result in a waiver of the Contractor's right to contest the City's warranty claim and permit the City to dispose of the failed products and assess any cost against the Contractor. The burden of proof when contesting warranty claims is solely on the Contractor. The life of the warranty supersedes the life of the contract and remains in effect for the full warranty term.

2. There will be no billing of replacement products until related contested warranty claim is resolved.
3. In the event of a contested claim as set forth above, or in the event of any contested claim associated with any repairs to warrantable products, the City and the Contractor will use their best efforts to mutually resolve the disagreement. In the event the City and the Contractor cannot resolve their disagreement within forty-five (45) calendar days subsequent to the Contractor's timely notice, the City's determination will be final.
  - a. City Repairs: The City may make minor repairs by replacing lids and casters to replace these failed parts on products under warranty. These repairs or parts replacement will be implemented at the sole discretion of the City and without any prior consent or notification to the Contractor.
  - b. Replacement Parts Guarantee: For the warranted serviceable life of the products, Contractor will be obligated to make available to the City all components of container(s)/lid(s) for use as replacement parts of defective and unserviceable products. Contractor will be obligated to make available to the City replacement parts of equal or superior quality and performance as original equipment manufactured parts. In the event that the Contractor is unable to provide the City with any replacement parts for a period longer than forty-five (45) calendar days, the Contractor will be liable to the City of any additional costs incurred by the City to repair or otherwise replace the container component and any and all other liquidated damages incurred by the City as a result of unavailability of the replacement part(s).

### 3.7. Delivery Schedule

- A. Containers will be delivered between the hours of 7:00 a.m. and 1:00 p.m. local (Arizona) time, Monday through Friday, excluding City recognized holidays. The CDCR will notify Contractor of a monthly delivery schedule once the contract is awarded. Contractor is responsible for notifying CDCR at least 24 hours before pending delivery. This notice will include estimated arrival time and order quantity to be delivered.
- B. The City may be required to adjust the amounts and the delivery locations of containers. The City reserves the right to modify the schedule as needed and will notify the Contractor in advance of any changes.
- C. Delivery will be completed within forty-five (45) calendar days after receipt of order by Contractor. The completion schedule will include any time for shipping of needed material and/or equipment. Any failure by the Contractor to provide and deliver containers within the 45-day timeframe, either original containers or warranty replacement containers, may result in liquidated damages owed to the City.
- D. Contractor will pay to the City for each calendar day of delay, the amount of seventy-five (\$75.00 U.S.) dollars per container/lid per calendar day for containers not received per the delivery schedule. The City may deduct these damages from subsequent invoice(s) to the



City. The City may also proceed against the warranty insurance. The City has the right to cancel the contract for recurring instances of unmet scheduled deliveries.

### 3.8. Delivery Requirements

- A. Contractor will provide all necessary vehicles and delivery equipment needed to unload product at CDCR designated location. Any changes in the delivery schedule will be communicated to the CDCR no later than 48 hours prior to pre-scheduled date/time.
- B. The contractor is required to notify the City prior to delivery so that City staff is present to verify and sign the Bill of Lading (BOL). The Contractor will provide a Bill of Lading (BOL) for each delivery of product
- C. The BOL will include the following information.
  - 1. Item Description
  - 2. Quantity
  - 3. Delivery Address
  - 4. Scheduled Delivery Date
  - 5. Serial Number Range For Load
  - 6. Purchase Order Number

## 4. Standard Terms and Conditions

### 4.1. Definition of Key Words Used in the Solicitation

**Shall, Will, Must:** Indicates a mandatory requirement. Failure to meet these mandatory requirements may result in the rejection of Offer as non-responsive.

**Should:** Indicates something that is recommended but not mandatory. If the Offeror fails to provide recommended information, the City may, at its sole option, ask the Offeror to provide the information or evaluate the Offer without the information.

**May:** Indicates something that is not mandatory but permissible.

For purposes of this solicitation, the following definitions will apply:

"A.R.S." Arizona Revised Statute

"Buyer" or "Procurement Officer" City of Phoenix staff person responsible for the solicitation. The City employee or employees who have specifically been designated to act as a contact person or persons to the Contractor, and responsible for monitoring and overseeing the Contractor's performance under this contract.

"City" The City of Phoenix

"Contractor" The individual, partnership, or corporation who, as a result of the competitive process, is awarded a contract by the City of Phoenix.

"Contract" or "Agreement" The legal agreement executed between the City of Phoenix, AZ and the Contractor.

"Days" Means calendar days unless otherwise specified.

"Chief Procurement Officer" The contracting authority for the City of Phoenix, AZ, authorized to sign contracts and amendments thereto on behalf of the City of Phoenix, AZ.

"Employer" Any individual or type of organization that transacts business in this state, that has a license issued by an agency in this state and employs one or more employees in this state. Employer includes this state, any political subdivision of this state and self-employed persons. In the case of an independent contractor, employer means the independent contractor and does not mean the person or organization that uses contract labor. (A.R.S. 23-211).

"Offer" Means a response from a Supplier, Contractor, or Service Provider to a solicitation request that, if awarded, binds the Supplier, Contractor, or Service Provider to perform in accordance with the contract. Same as bid, proposal, quotation or tender.

"Offeror" Any Vendor, Seller or Supplier submitting a competitive offer in response to a solicitation from the City. Same as Bidder or Proposer.

"Solicitation" Means an Invitation for Bid (IFB), Request for Proposal (RFP), Request for Quotations (RFQ), Request for Qualifications (RFQu) and request for sealed Offers, or any other type of formal procurement which the City makes public through advertising, mailings, or some other method of communication. It is the process by which the City seeks information, proposals, Offers, or quotes from suppliers.

“Suppliers” Firms, entities or individuals furnishing goods or services to the City.

“Vendor or Seller” A seller of goods or services.

## 4.2. Contract Interpretation

- A. **Applicable Law:** This Contract will be governed by the law of the State of Arizona, and suits pertaining to this Contract will be brought only in Federal or State courts in Maricopa County, State of Arizona.
- B. **Contract Order of Precedence:** In the event of a conflict in the provisions of the Contract, as accepted by the City and as they may be amended, the following will prevail in the order set forth below:
1. Federal terms and conditions, if any
  2. Special terms and conditions
  3. Standard terms and conditions
  4. Amendments
  5. Statement or scope of work
  6. Specifications
  7. Attachments
  8. Exhibits
  9. Instructions to Contractors
  10. Other documents referenced or included in the Solicitation
- C. **Organization – Employment Disclaimer:** The Agreement resulting hereunder is not intended to constitute, create, give rise to or otherwise recognize a joint venture agreement or relationship, partnership or formal business organization of any kind, and the rights and obligations of the parties will be only those expressly set forth in the agreement. The parties agree that no persons supplied by the Contractor in the performance of Contractor’s obligations under the agreement are considered to be City’s employees and that no rights of City civil service, retirement or personnel rules accrue to such persons. The Contractor will have total responsibility for all salaries, wage bonuses, retirement, withholdings, workmen’s compensation, occupational disease compensation, unemployment compensation, other employee benefits and all taxes and premiums appurtenant thereto concerning such persons, and will save and hold the City harmless with respect thereto.
- D. **Severability:** The provisions of this Contract are severable to the extent that any provision or application held to be invalid will not affect any other provision or application of the contract which may remain in effect without the invalid provision or application.

- E. **Non-Waiver of Liability:** The City of Phoenix as a public entity supported by tax monies, in execution of its public trust, cannot agree to waive any lawful or legitimate right to recover monies lawfully due it. Therefore, any Contractor agrees that it will not insist upon or demand any statement whereby the City agrees to limit in advance or waive any right the City might have to recover actual lawful damages in any court of law under applicable Arizona law.
- F. **Parol Evidence:** This Agreement is intended by the parties as a final expression of their agreement and is intended also as a complete and exclusive statement of the terms of this agreement. No course of prior dealings between the parties and no usage in the trade will be relevant to supplement or explain any term used in this Contract. Acceptance or acquiescence in a course of performance rendered under this contract will not be relevant to determine the meaning of this Contract even though the accepting or acquiescing party has knowledge of the nature of the performance and opportunity to object.

#### 4.3. Contract Administration and Operation

- A. **Records:** All books, accounts, reports, files and other records relating to the contract will be subject at all reasonable times to inspection and audit by the City for five years after completion of the contract. Such records will be produced at a City of Phoenix office as designated by the City. Confidentiality will be maintained, and City will not violate any proprietary or other confidentiality agreements Contractor has in place.
- B. **Discrimination Prohibited:** Contractor agrees to abide by the provisions of the Phoenix City Code Chapter 18, Article V as amended. Any Contractor, in performing under this contract, will not discriminate against any worker, employee or applicant, or any member of the public, because of race, color, religion, sex, national origin, age or disability nor otherwise commit an unfair employment practice. The supplier and/or lessee will take action to ensure that applicants are employed, and employees are dealt with during employment without regard to their race, color, religion, sex, or national origin, age or disability and adhere to a policy to pay equal compensation to men and women who perform jobs that require substantially equal skill, effort and responsibility, and that are performed within the same establishment under similar working conditions. Such action will include but not be limited to the following: Employment, promotion, demotion or transfer, recruitment or recruitment advertising, layoff or termination; rates of pay or other forms of compensation; and selection for training; including apprenticeship. The supplier further agrees that this clause will be incorporated in all subcontracts with all labor organizations furnishing skilled, unskilled and union labor, or who may perform any such labor or services in connection with this contract. Contractor further agrees that this clause will be incorporated in all subcontracts, job-contractor agreements or subleases of this agreement entered into by supplier/lessee.
- C. **Equal Employment Opportunity and Pay:** In order to do business with the City, Contractor must comply with Phoenix City Code, 1969, Chapter 18, Article V, as amended,

Equal Employment Opportunity Requirements. Contractor will direct any questions in regard to these requirements to the Equal Opportunity Department, (602) 262-6790.

1. **For a Contractor with 35 employees or fewer:** Contractor in performing under this Agreement shall not discriminate against any worker, employee or applicant, or any member of the public, because of race, color, religion, sex, national origin, age, or disability, nor otherwise commit an unfair employment practice. The Contractor will ensure that applicants are employed, and employees are dealt with during employment without regard to their race, color, religion, sex, national origin, age, or disability. Such action shall include but not be limited to the following: employment, promotion, demotion or transfer, recruitment or recruitment advertising, layoff or termination; rates of pay or other forms of compensation; and selection for training; including apprenticeship. The Contractor further agrees that this clause will be incorporated in all subcontracts related to this Agreement that involve furnishing skilled, unskilled and union labor, or who may perform any such labor or services in connection with this Agreement. Contractor further agrees that this clause will be incorporated in all subcontracts, Contractor agreements or subleases of this agreement entered into by supplier/lessee.
  
2. **For a Contractor with more than 35 employees:** Contractor in performing under this Agreement shall not discriminate against any worker, employee or applicant, or any member of the public, because of race, color, religion, sex, national origin, age, or disability, nor otherwise commit an unfair employment practice. The Contractor will ensure that applicants are employed, and employees are dealt with during employment without regard to their race, color, religion, sex, national origin, age, or disability, and shall adhere to a policy to pay equal compensation to men and women who perform jobs that require substantially equal skill, effort, and responsibility, and that are performed within the same establishment under similar working conditions. Such action shall include but not be limited to the following: employment, promotion, demotion or transfer, recruitment or recruitment advertising, layoff or termination; rates of pay or other forms of compensation; and selection for training; including apprenticeship. The Contractor further agrees that this clause will be incorporated in all subcontracts with all labor organizations furnishing skilled, unskilled and union labor, or who may perform any such labor or services in connection with this contract. Contractor further agrees that this clause will be incorporated in all subcontracts, job-Contractor agreements or subleases of this Agreement entered into by supplier/lessee. The Contractor further agrees not to discriminate against any worker, employee or applicant, or any member of the public, because of sexual orientation or gender identity or expression and shall ensure that applicants are employed, and employees are dealt with during employment without regard to their sexual orientation or gender identity or expression.

3. **Documentation:** Suppliers and lessees may be required to provide additional documentation to the Equal Opportunity Department affirming that a nondiscriminatory policy is being utilized.
  4. **Monitoring:** The Equal Opportunity Department shall monitor the employment policies and practices of suppliers and lessees subject to this article as deemed necessary. The Equal Opportunity Department is authorized to conduct on-site compliance reviews of selected firms, which may include an audit of personnel and payroll records, if necessary.
- D. **Legal Worker Requirements:** The City of Phoenix is prohibited by A.R.S. § 41-4401 from awarding a contract to any Contractor who fails, or whose subcontractors fail, to comply with A.R.S. § 23-214(A). Therefore, Contractor agrees that:
1. Contractor and each subcontractor it uses warrants their compliance with all federal immigration laws and regulations that relate to their employees and their compliance with A.R.S. § 23-214, subsection A.
  2. A breach of a warranty under paragraph 1 will be deemed a material breach of the contract that is subject to penalties up to and including termination of the contract.
  3. The City of Phoenix retains the legal right to inspect the papers of any Contractor or subcontractor employee who works on the contract to ensure that the Contractor or subcontractor is complying with the warranty under paragraph 1.
- E. **Health, Environmental, and Safety Requirements:** The Contractor's products, services and facilities will be in full compliance with all applicable Federal, State and local health, environmental and safety laws, regulations, standards, codes and ordinances, regardless of whether or not they are referred to by the City. At the request of City representatives, the Contractor will provide the City:
1. Environmental, safety and health regulatory compliance documents (written safety programs, training records, permits, etc.) applicable to services provided by the Contractor in this contract.
  2. A list of all federal, state, or local (EPA, OSHA, Maricopa County, etc.) citations or notice of violations issued against their firm or their subcontractors including dates, reasons, dispositions and resolutions.
  3. The City will have the right, but not the obligation to inspect the facilities, transportation vehicles or vessels, containers and disposal facilities provided by the Contractor or subcontractor. The City will also have the right to inspect operations conducted by the Contractor or subcontractor in the performance of this agreement. The City further reserves the right to make unannounced inspections of the Contractor's facilities (during normal business hours).
- F. **Compliance with Laws:** Contractor agrees to fully observe and comply with all applicable Federal, State and local laws, regulations, standards, codes and ordinances when

performing under this Contract regardless of whether they are being referred to by the City. Contractor agrees to permit City inspection of Contractor's business records, including personnel records to verify any such compliance. Because the contractor will be acting as an independent contractor, the City assumes no responsibility for the Contractor's acts.

- G. **Lawful Presence Requirement:** Pursuant to A.R.S. §§ 1-501 and -502, the City of Phoenix is prohibited from awarding a contract to any natural person who cannot establish that he or she is lawfully present in the United States. In order to establish lawful presence, this person must produce qualifying identification and sign a City-provided affidavit affirming that the identification provided is genuine. This requirement will be imposed at the time of contract award. In the event the prevailing responder is unable to satisfy this requirement, the City will offer the award to the next-highest scoring responder. The law does not apply to fictitious entities such as corporations, partnerships and limited liability companies.
- H. **Continuation During Disputes:** Contractor agrees that notwithstanding the existence of any dispute between the parties, insofar as is possible, under the terms of the contract, the Contractor will continue to perform the obligations required of Contractor during the continuation of any such dispute unless enjoined or prohibited by an Arizona Court of competent jurisdiction.
- I. **Emergency Purchases:** The City reserves the right to purchase from other sources those items which are required on an emergency basis and cannot be supplied immediately from stock by the Contractor.

#### 4.4. Costs and Payments

- A. **General:** Any prompt payment terms offered must be clearly noted by the Contractor on all invoices submitted to the City for the payment of goods or services received. The City will make every effort to process payment for the purchase of material or services within thirty to forty-five calendar days after receipt of a correct invoice, unless a good faith dispute exists to any obligation to pay all or a portion of the account. Payment terms are specified in the Offer.
- B. **Payment Deduction Offset Provision:** Contractor acknowledges that the City Charter requires that no payment be made to any Contractor as long as there is an outstanding obligation due to the City. Contractor agrees that any obligation it owes to the City will be offset against any payment due to the Contractor from the City.
- C. **Late Submission of Claim by Contractor:** The City will not honor any invoices or claims which are tendered one year after the last item of the account accrued.
- D. **Discounts:** If applicable, payment discounts will be computed from the date of receiving acceptable products, materials and/or services or correct invoice, whichever is later to the date payment is mailed.

- E. **No Advance Payments:** Advance payments are not authorized. Payment will be made only for actual services or commodities that have been received, unless addressed specifically in the Scope of work for subscription services.
- F. **Fund Appropriation Contingency:** The Contractor recognizes that any agreement entered into will commence upon the day first provided and continue in full force and effect until termination in accordance with its provisions. The Contractor and the City herein recognize that the continuation of any contract after the close of any given fiscal year of the City, which ends on June 30th of each year, will be subject to the approval of the budget of the City providing for or covering such contract item as an expenditure therein. The City does not represent that said budget item will be actually adopted, said determination being the determination of the City Council at the time of the adoption of the budget.
- G. **Maximum Prices:** The City will not be invoiced at prices higher than those stated in any contract resulting from this Offer. Contractor certifies, by signing this Offer that the prices offered are no higher than the lowest price the Contractor charges other buyers for similar quantities under similar conditions, as applicable and shown by quotes for like services and goods. Contractor further agrees that any reductions in the price of the goods or services covered by this Offer and occurring after award will apply to the undelivered balance. The Contractor will promptly notify the City of such price reductions.
- H. **F.O.B. Point:** All prices are to be quoted F.O.B. destination, unless specified elsewhere in this solicitation.

#### 4.5. Contract Changes

- A. **Contract Amendments:** Contracts will be modified only by a written contract amendment signed by persons duly authorized to enter into contracts on behalf of the Contractor. No verbal agreement or conversation with any officer, agent, or employee of the City either before or after execution of the contract, will affect or modify any of the terms or obligations contained or to be contained in the contract. Any such verbal agreements or conversation shall be considered as unofficial information and in no way binding upon the City or the Contractor. All agreements shall be in writing and contract changes shall be by written amendment signed by both parties.
- B. **Assignment - Delegation:** No right or interest in this contract nor monies due hereunder will be assigned in whole or in part without written permission of the City, and no delegation of any duty of Contractor will be made without prior written permission of the City, which may be withheld for good cause. Any assignment or delegation made in violation of this section will be void.
- C. **Non-Exclusive Contract:** Any contract resulting from this solicitation will be awarded with the understanding and agreement that it is for the sole convenience of the City. The City reserves the right to obtain like goods or services from another source when necessary.



#### 4.6. Risk of Loss and Liability

- A. **Title and Risk of Loss:** The title and risk of loss of material or service will not pass to the City until the City actually receives the material or service at the point of delivery; and such loss, injury, or destruction will not release seller from any obligation hereunder.
- B. **Acceptance:** All material or service is subject to final inspection and acceptance by the City. Material or service failing to conform to the specifications of this contract will be held at Contractor's risk and may be returned to the Contractor. If so returned, all costs are the responsibility of the Contractor. Noncompliance will conform to the cancellation clause set forth in this document.
- C. **Force Majeure:** Except for payment of sums due, neither party will be liable to the other nor deemed in default under this contract if and to the extent that such party's performance of this contract is prevented by reason of force majeure. The term "force majeure" means an occurrence that is beyond the control of the party affected and occurs without its fault or negligence. Force majeure will not include late performance by a subcontractor unless the delay arises out of a force majeure occurrence in accordance with this force majeure term and condition. If either party is delayed at any time in the progress of the work by force majeure, the delayed party will notify the other party in writing of such delay, as soon as is practical, of the commencement thereof and will specify the causes of such delay in such notice. Such notice will be hand-delivered or mailed certified-return receipt and will make a specific reference to this provision, thereby invoking its provisions. The delayed party will cause such delay to cease as soon as practicable and will notify the other party in writing when it has done so. The time of completion will be extended by contract modification for a period of time equal to the time that results or effects of such delay prevent the delayed party from performing in accordance with this contract.
- D. **Loss of Materials:** The City does not assume any responsibility, at any time, for the protection of or for loss of materials, from the time that the contract operations have commenced until the final acceptance of the work by the City.
- E. **Contract Performance:** Contractor will furnish all necessary labor, tools, equipment, and supplies to perform the required services at the City facilities designated, unless otherwise specifically addressed in the scope, or elsewhere in this Agreement. The City's authorized representative will decide all questions which may arise as to the quality and acceptability of any work performed under the contract. If, in the opinion of the City's authorized representative, performance becomes unsatisfactory, the City will notify the Contractor. The Contractor will have 30 days from that time to correct any specific instances of unsatisfactory performance, unless a different amount of time is specified in the agreement. In the event the unsatisfactory performance is not corrected within the time specified, the City will have the immediate right to complete the work to its satisfaction and will deduct the cost to cover from any balances due or to become due the Contractor. Repeated incidences of unsatisfactory performance may result in cancellation of the agreement for default.

- F. **Damage to City Property:** Contractor will perform all work so that no damage to the building or grounds results. Contractor will repair any damage caused to the satisfaction of the City at no cost to the City. Contractor will take care to avoid damage to adjacent finished materials that are to remain. If finished materials are damaged, Contractor will repair and finish to match existing material as approved by the City at Contractor's expense.

#### 4.7. City's Contractual Rights

Whenever one party to this contract in good faith has reason to question the other party's intent to perform, the former party may demand that the other party give a written assurance of this intent to perform. In the event that a demand is made and no written assurance is given within five days, the demanding party may treat this failure as an anticipatory repudiation of this contract.

- A. **Non-Exclusive Remedies:** The rights and remedies of the City under this Contract are non-exclusive.
- B. **Default in One Installment to Constitute Breach:** Each installment or lot of the agreement is dependent on every other installment or lot and a delivery of non-conforming goods or a default of any nature under one installment or lot will impair the value of the whole agreement and constitutes a total breach of the agreement as a whole.
- C. **On Time Delivery:** Because the City is providing services which involve health, safety and welfare of the general public, delivery time is of the essence. Delivery must be made in accordance with the delivery schedule promised by the Contractor.
- D. **Default:** In case of default by the Contractor, the City may, by written notice, cancel this contract and repurchase from another source and may recover the excess costs by (1) deduction from an unpaid balance due; (2) collection against the Solicitation and/or Performance Bond, or (3) a combination of the aforementioned remedies or other remedies as provided by law.
- E. **Covenant Against Contingent Fees:** Seller warrants that no person or selling agent has been employed or retained to solicit or secure this contract upon an agreement or understanding for a commission, percentage, brokerage, or contingent fee, excepting bona fide employers or bona fide established commercial or selling agencies maintained by the seller for the purpose of securing business. For breach or violation of this warranty, the City will have the right to annul the contract without liability or in its discretion to deduct from the contract price a consideration, or otherwise recover the full amount of such commission, brokerage or contingent fee.
- F. **Cost Justification:** In the event only one response is received, the City may require that the Contractor submit a cost proposal in sufficient detail for the City to perform a cost/price analysis to determine if the Offer price is fair and reasonable.
- G. **Work Product, Equipment, and Materials:** All work product, equipment, or materials created or purchased under this contract belongs to the City and must be delivered to the City at City's request upon termination of this contract. Contractor agrees to assign to City

all rights and interests Contractor may have in materials prepared under this contract that are “works for hire” within the meaning of the copyright laws of the United States, including any right to derivative use of the material.

#### 4.8. Contract Termination

A. **Gratuities:** The City may, by written notice to the Contractor, cancel this contract if it is found that gratuities, in the form of entertainment, gifts or otherwise, were offered or given by the Contractor or any agent or representative of the Contractor, to any officer or employee of the City making any determinations with respect to the performing of such contract. In the event this contract is canceled by the City pursuant to this provision, the City will be entitled, in addition to any other rights and remedies, to recover or withhold from the Contractor the amount of the gratuity.

B. **Conditions and Causes for Termination:**

1. This contract may be terminated at any time by mutual written consent, or by the City, with or without cause, upon giving thirty-day written notice to Contractor. The City at its convenience, by written notice, may terminate this contract, in whole or in part. If this contract is terminated, the City will be liable only for payment under the payment provisions of this contract for services rendered and accepted material received by the City before the effective date of termination. Title to all materials, work-in-process and completed but undeliverable goods, will pass to the City after costs are claimed and allowed. The Seller will submit detailed cost claims in an acceptable manner and will permit the City to examine such books and records as may be necessary in order to verify the reasonableness of any claims.
2. The City reserves the right to cancel the whole or any part of this contract due to failure of Contractor to carry out any term, promise, or condition of the contract. The City will issue a written notice of default to Contractor for acting or failing to act as in any of the following:
  - In the opinion of the City, Contractor provides personnel who do not meet the requirements of the contract;
  - In the opinion of the City, Contractor fails to perform adequately the stipulations, conditions or services/specifications required in this contract;
  - In the opinion of the City, Contractor attempts to impose on the City personnel or materials, products or workmanship, which is of an unacceptable quality;
  - Contractor fails to furnish the required service and/or product within the time stipulated in the contract;
  - In the opinion of the City, Contractor fails to make progress in the performance of the requirements of the contract and/or gives the City a positive indication that Contractor will not or cannot perform to the requirements of the contract.

- C. **Contract Cancellation:** All parties acknowledge that this contract is subject to cancellation by the City of Phoenix pursuant to the provision of Section 38-511, Arizona Revised Statutes.

#### 4.9. Notice

Any notice, consent or other communication (“Notice”) required or permitted under this Agreement will be in writing and either: (1) delivered in person; (2) sent via e-mail, return receipt requested; (3) sent via facsimile transmission; (4) deposited with any commercial air courier or express delivery service; or (5) deposited in the United States mail, postage prepaid.

Notices to the City shall be sent to: City of Phoenix Public Works Department, Solid Waste Division, [pwd.solicitations@phoenix.gov](mailto:pwd.solicitations@phoenix.gov)

Notice to Contractor shall be sent to the person at the mailing address, email address, or fax number listed by Contractor in its Offer in Submittal Forms - Offer Page

#### 4.10. Integration

This Agreement constitutes and embodies the full and complete understanding and agreement of the parties hereto and supersedes all prior understandings, agreements, discussions, proposals, bids, negotiations, communications, and correspondence, whether oral or written. No representation, promise, inducement or statement of intention has been made by any party hereto which is not embodied in this Agreement, and no party will be bound by or liable for any statement of intention not so set forth.

#### 4.11. State and Local Transaction Privilege Taxes

In accordance with applicable state and local law, transaction privilege taxes may be applicable to this transaction. The state and local transaction privilege (sales) tax burden and legal liability to remit taxes are on the Contractor that is conducting business in Arizona and the City of Phoenix. Any failure by the Contractor to collect applicable taxes from the City will not relieve the Contractor from its obligation to remit taxes. It is the responsibility of the prospective bidder to determine any applicable taxes. The City will look at the price or offer submitted and will not deduct, add or alter pricing based on speculation or application of any taxes, nor will the City provide advice or guidance. If you have questions regarding your tax liability, please seek advice from a tax professional prior to submitting your Offer. You may also find information at <https://www.phoenix.gov/finance/plt> or <https://www.azdor.gov/Business>. Once your Offer is submitted, the Offer is valid for the time specified in this Solicitation, regardless of mistake or omission of tax liability. If the City finds over payment of a project due to tax consideration that was not due, the Contractor will be liable to the City for that amount, and by contracting with the City, the Contractor agrees to remit any overpayments back to the City for miscalculations on taxes included in an offer price.

#### 4.12. Tax Indemnification

Contractor will pay all federal, state and local taxes applicable to its operation and any persons employed by the Contractor, and require the same of all subcontractors. Contractor will hold the City harmless from any responsibility for taxes, damages and interest, if applicable, contributions required under federal, and/or state and local laws and regulations and any other costs including

transaction privilege taxes, unemployment compensation insurance, Social Security and Worker's Compensation, and require the same of all subcontractors.

#### 4.13. Tax Responsibility Qualification

Contractor may be required to establish, to the satisfaction of City, that any and all fees and taxes due to the City or the State of Arizona for any License or Transaction Privilege taxes, Use Taxes or similar excise taxes, are currently paid (except for matters under legal protest). Contractor agrees to a waiver of the confidentiality provisions contained in the City Finance Code and any similar confidentiality provisions contained in Arizona statutes relative to State Transaction Privilege Taxes or Use Taxes. Contractor agrees to provide written authorization to the City Finance Department and to the Arizona State Department of Revenue to release tax information relative to Arizona Transaction Privilege Taxes or Arizona Use Taxes in order to assist the Department in evaluating Contractor's qualifications for and compliance with contract for duration of the term of contract.

#### 4.14. No Israel Boycott

If this Contract is valued at \$100,000 or more and requires Contractor (a company engaging in for-profit activity and having ten or more full-time employees) to acquire or dispose of services, supplies, information technology, or construction, then Contractor must certify and agree that it does not and will not boycott goods or services from Israel, pursuant to Title 35, Chapter 2, Article 9 of the Arizona Revised Statutes. Provided that these statutory requirements are applicable, Contractor by entering this Contract now certifies that it is not currently engaged in, and agrees for the duration of the Contract to not engage in, a boycott of goods or services from Israel.

#### 4.15. No Forced Labor of Ethnic Uyghurs

If this Contract requires Contractor (a company engaging in for-profit activity and having ten or more full-time employees) to acquire or dispose of services, supplies, information technology, goods, or construction, then pursuant to Title 35, Chapter 2, Article 10 of the Arizona Revised Statutes Contractor must certify and agree that it and any contractors, subcontractors, or suppliers it utilizes do not and will not use the forced labor of ethnic Uyghurs in the People's Republic of China or any goods or services produced by such forced labor. Provided these statutory requirements are applicable, Contractor, by entering this Contract, now certifies it is not currently engaged in, and agrees for the duration of the Contract to not engage in, (a) the use of forced labor of ethnic Uyghurs in the People's Republic of China; (b) the use of any goods or services produced by the forced labor of ethnic Uyghurs in the People's Republic of China; or (c) the use of any contractors, subcontractors, or suppliers that use the forced labor or any goods or services produced by the forced labor of ethnic Uyghurs in the People's Republic of China.

#### 4.16. Advertising

Except as required by law, Contractor shall not publish, release, disclose or announce to any member of the public, press, official body, or any other third party any information or documents concerning this Agreement or any part thereof without the prior written consent of the City. The name of any City site on which services are performed by the Contractor pursuant to this Agreement shall not be used in any advertising or other promotional context by Contractor without the prior written consent of the City.

#### 4.17. Strict Performance

Failure of either party to insist upon the strict performance of any item or condition of the contract or to exercise or delay the exercise of any right or remedy provided in the contract, or by law, or the acceptance of materials or services, obligations imposed by this contract, or by law, will not be deemed a waiver of any right of either party to insist upon the strict performance of the contract.

#### 4.18. Authorized Changes

The City reserves the right at any time to make changes in any one or more of the following: (a) specifications; (b) methods of shipment or packing; (c) place of delivery; (d) time of delivery; and/or (e) quantities. If the change causes an increase or decrease in the cost of or the time required for performance, an equitable adjustment may be made in the price or delivery schedule, or both. Any claim for adjustment will be deemed waived unless asserted in writing within sixty days from the receipt of the change. Price increases or extensions of delivery time will not be binding on the City unless evidenced in writing and approved by the Chief Procurement Officer prior to the institution of the change.

#### 4.19. Contractor Requirements for the Mitigation of Heat-Related Illnesses and Injuries in the Workplace

Any contractor whose employees and contract workers perform work in an outdoor environment under this contract must keep on file a written heat safety plan. The city may request a copy of this plan and documentation of all heat safety and mitigation efforts currently implemented to prevent heat-related illnesses and injuries in the workplace. The plan must also be posted where it is accessible to employees. At a minimum, the heat safety and mitigation plan and documentation required under this provision shall include each of the following as it relates to heat safety and mitigation:

- A. Availability of sanitized cool drinking water free of charge at locations that are accessible to all employees and contract workers.
- B. Ability to take regular and necessary breaks as needed and additional breaks for hydration.
- C. Access to shaded areas and/or air conditioning.
- D. Access to air conditioning in vehicles with enclosed cabs. All such vehicles must contain functioning air conditioning by no later than May 1, 2025.
- E. Effective acclimatization practices to promote the physiological adaptations of employees or contract workers newly assigned or reassigned to work in an outside environment.
- F. Conduct training and make it available and understandable to all employees and contract workers on heat illness and injury that focuses on the environmental and personal risk factors, prevention, how to recognize and report signs and symptoms of heat illness and injury, how to administer appropriate first aid measures and how to report heat illness and injury to emergency medical personnel.

The contractor further agrees that this clause will be incorporated in all subcontracts with subcontractors, sublicensees or sublessees who may perform labor or services in connection with

this contract. Additionally, the contractor agrees to require all subcontractors, sublicensees or sublessees to include this clause in all contracts with any third party who is contracted to perform labor or services in connection with this contract. It is the obligation of the contractor to ensure compliance by its subcontractors.

## 5. Special Terms and Conditions

### 5.1. Term of Contract

The term of this Contract will commence on or about June 1, 2025 and will continue for a period of **three (3) years** thereafter. This Contract includes **two (2) one-year options** to extend the term, for an aggregate **five (5) years**, which may be exercised by the sole discretion of the City.

### 5.2. Free on Board (FOB)

Prices quoted shall be FOB destination and delivered, as required, to the following point(s): Union Hills Transfer Station 138 E. Union Hills Drive Phoenix, AZ 85024 and 27th Ave Transfer Station 3060 S. 27th Ave Phoenix, AZ 85009.

### 5.3. Price

All prices submitted shall be firm and fixed for the initial one-year of the contract. Thereafter, price increases will be considered annually provided the adjustments are submitted in writing with 60 days' notice to the Procurement Officer. Price increase requests shall be accompanied with written documentation to support the increase, such as a letter from the manufacturer, published price index, applicable change in law, etc. Price decrease requests do not require supporting documentation and are allowed at any time during the contract term.

The City will be the sole judge in determining the allowable increase amount. Price increases agreed to by any staff other than the Chief Procurement Officer are invalid. The Contractor acknowledges and agrees to repay all monies paid because of a requested price increase unless the increase was specifically approved, in writing, by the Chief Procurement Officer.

### 5.4. Method of Ordering

Contractor shall deliver items and/or services only upon receipt of a written purchase order. All Contractor invoices and packing/delivery tickets must include the City of Phoenix purchase order number.

### 5.5. Method of Invoicing

Invoice must be emailed in .pdf format to [invoices@phoenix.gov](mailto:invoices@phoenix.gov) and must include the following:

- City purchase order number or shopping cart number
- Items listed individually by the written description and part number
- Unit price, extended and totaled
- Quantity ordered, back ordered, and shipped
- Applicable tax
- Invoice number and date
- Delivery address
- Payment terms



- FOB terms
- Remit to address

## 5.6. Method of Payment

Contractor will be paid on a N/A basis in arrears.

## 5.7. Partial Payments

Partial payments are authorized on individual purchase orders. Payment will be made for actual goods and services received and accepted by the City.

## 5.8. Supplier Profile Changes

It is the responsibility of the Contractor to promptly update their profile in procurePHX at <https://www.phoenix.gov/procure>. If Contractor's legal identify has changed, the Procurement Officer must be notified immediately. Failure to do so may result in non-payment of invoices and contract termination.

## 5.9. Estimated Quantities or Dollar Amounts (Requirements Contracts Only)

Quantities and dollar amounts listed are the City's best estimate and do not obligate the City to order or accept more than City's actual requirements during the period of this agreement, as determined by actual needs and availability or appropriated funds. It is expressly understood and agreed that the resulting contract is to supply the City with its complete actual requirement for the contract period.

## 5.10. Suspensions of Work

The City reserves the right to suspend work wholly or in part if deemed necessary for the best interest of the City. This suspension will be without compensation to the Contractor, other than to adjust the contract completion/delivery requirements.

## 5.11. Post Award Conference

A post-award conference will be held prior to commencement of any work on the project. The purpose of this conference is to discuss critical elements of the work schedule and operational problems and procedures.

## 5.12. Performance Interference

Contractor shall notify the City's authorized Department representative immediately of any occurrence and/or condition that interferes with the full performance of the contract and confirm it in writing within 24 hours.

Department Contact: Vanessa Castillo, Administrative Assistant II

Phone: 602-495-2442

### 5.13. Cooperative Agreement

In addition to the City and with approval of the Contractor, this contract may be extended for use by other municipalities and government agencies in the State of Arizona.

### 5.14. Licenses and Permits

Contractor will keep current Federal, State, and local licenses and permits required for the operation of the business conducted by the Contractor as applicable to this contract.

### 5.15. Delivery

All deliveries shall be made between the hours of 7:00 a.m. and 1:00 p.m. local (Arizona) time, local time, Monday through Friday, excluding City holidays. City holiday calendar: <https://www.phoenix.gov/calendar/holidays>

### 5.16. Delivery / Service Ticket

Contractor shall provide a packing list or service ticket for items delivered to the City or services provided to the City. Tickets should include the following and a legible copy shall be provided to the City:

- Date
- City purchase order number
- Written description of services which were provided
- Itemized list of materials which were delivered, including quantity
- A unique identification number and Contractor name
- Signature of City employee who accepted for the materials/services

### 5.17. Miscellaneous Fees

Additional charges for fuel surcharges, delivery charges, dealer prep, environmental fees, waste disposal, shop supplies, set-up, freight and/or shipping and handling, etc. will not be paid. These costs must be incorporated in the pricing provided.

Labor rates (Shop and On-site) shall be charged as a flat hourly rate and are allowed only in performance of services under this agreement. Travel hours and other incidental fees will not be permitted under this agreement. Labor hours will be from “check-in” to “check-out” at the worksite.

### 5.18. Liquidated Damages

If the Contractor fails to deliver the supplies or perform the services within the time specified in its contract, or any extension thereof, the actual damages to the City for the delay will be difficult or impossible to determine. Therefore, in lieu of actual damages, the Contractor shall pay to the City as fixed, agreed and liquidated damages for each calendar day of the delay per container/lid for containers/lids not received per the delivery schedule, the amount of \$75.00. The City may terminate this contract in whole or in part as provided in the “Default” provision. In that event, the Contractor shall be liable for such liquidated damages accruing until the City may reasonably obtain delivery or performance of similar supplies and services. The Contractor shall not be

charged with liquidated damages when the delay arises out of causes beyond its control and without fault or negligence, as determined by the City. The Chief Procurement Officer will be the sole judge in determining the liquidated damages.

### 5.19. Industry Standards

It is intended that the manufacturer in the selection of components will use material and design practices that are the best available in the industry for the type of operating conditions to which the item will be subjected. Component parts shall be selected to give maximum performance, service life and safety and not merely meet the minimum requirements of this specification. All parts, equipment and accessories shall conform in strength, quality of material and workmanship to recognized industry standards.

The term "heavy duty" if used in these specifications shall mean that the item to which the term is applied shall exceed the usual quantity, quality, or capacity supplied with standard production items and it shall be able to withstand unusual straining, exposure, temperature, wear and use.

The City reserves the right to waive minor variations if, in the opinion of the City's authorized Department representative, the basic unit meets the general intent of these specifications.

The product offered shall not include a major component that is of a prototype nature or has not been in production for a sufficient length of time to demonstrate reliability.

If the specifications stated herein for component items do not comply with legal requirements, the Contractor shall so notify the City prior to the offer opening due date.

### 5.20. New Equipment

All items offered shall be new equipment supplied from the manufacturer. Offers for remanufactured/refurbished equipment will be considered as non-responsive and rejected.

## **6. Defense and Indemnification**

### **6.1. Standard General Defense and Indemnification**

Contractor (“Indemnitor”) must defend, indemnify, and hold harmless the City of Phoenix and its officers, officials (elected or appointed), agents, and employees (“Indemnitee”) from and against any and all claims, actions, liabilities, damages, losses or expenses (including but not limited to court costs, attorney fees, expert fees, and costs of claim processing, investigation and litigation) of any nature or kind whatsoever (“Losses”) caused, or alleged to be caused, in whole or in part, by the wrongful, negligent or willful acts, or errors or omissions of Indemnitor or any of its owners, officers, directors, members, managers, agents, employees or subcontractors (“Indemnitor’s Agents”) arising out of or in connection with this Contract. This defense and indemnity obligation includes holding Indemnitee harmless for any Losses arising out of or recovered under any state’s Workers’ Compensation Law or arising out of the failure of Indemnitor or Indemnitor’s Agents to conform to any federal, state or local law, statute, ordinance, rule, regulation or court decree. Indemnitor’s duty to defend Indemnitee accrues immediately at the time a claim is threatened or a claim is made against Indemnitee, whichever is first. Indemnitor’s duty to defend exists regardless of whether Indemnitor is ultimately found liable. Indemnitor must indemnify Indemnitee from and against any and all Losses, except where it is proven that those Losses are solely a result of Indemnitee’s own negligent or willful acts or omissions. Indemnitor will be responsible for primary loss investigation, defense and judgment costs where this indemnification applies. In consideration of the award of this Contract, Indemnitor waives all rights of subrogation against Indemnitee for losses arising from the work performed by Indemnitor or Indemnitor’s Agents for the City of Phoenix. The obligations of Indemnitor under this provision survive the termination or expiration of this Contract.

## 7. Insurance Requirements

### 7.1. Contractor's Insurance

Contractor and subcontractors must procure insurance against claims that may arise from or relate to performance of the work hereunder by Contractor and its agents, representatives, employees and subcontractors. Contractor and subcontractors must maintain that insurance until all their obligations have been discharged, including any warranty periods under this Contract.

The City in no way warrants that the limits stated in this section are sufficient to protect the Contractor from liabilities that might arise out of the performance of the work under this Contract by the Contractor, its agents, representatives, employees or subcontractors and Contractor may purchase additional insurance as they determine necessary.

### 7.2. Scope and Limits of Insurance

Contractor must provide coverage with limits of liability not less than those stated below. An excess liability policy or umbrella liability policy may be used to meet the liability limits provided that (1) the coverage is written on a "following form" basis, and (2) all terms under each line of coverage below are met.

### 7.3. Commercial General Liability – Occurrence Form

General Aggregate	\$2,000,000
Products – Completed Operations Aggregate	\$1,000,000
Personal and Advertising Injury	\$1,000,000
Each Occurrence	\$1,000,000

- The policy must name the City of Phoenix as an additional insured with respect to liability for bodily injury, property damage and personal and advertising injury with respect to premises, ongoing operations, products and completed operations and liability assumed under an insured contract arising out of the activities performed by, or on behalf of the Contractor related to this Contract.
- There shall be no endorsement or modification which limits the scope of coverage or the policy limits available to the City of Phoenix as an additional insured.
- City of Phoenix is an additional insured to the full limits of liability purchased by the Contractor.
- The Contractor's insurance coverage must be primary and non-contributory with respect to any insurance or self-insurance carried by the City.

### 7.4. Automobile Liability

Bodily Injury and Property Damage coverage for any owned, hired, and non-owned vehicles used in the performance of this Contract.

Combined Single Limit (CSL)	\$1,000,000
-----------------------------	-------------

- The policy must be endorsed to include the City of Phoenix as an additional insured with respect to liability arising out of the activities performed by, or on behalf of the Contractor, relating to this Contract.
- City of Phoenix is an additional insured to the full limits of liability purchased by the Contractor.
- The Contractor’s insurance coverage must be primary and non-contributory with respect to any insurance or self-insurance carried by the City.

## 7.5. Worker’s Compensation and Employers’ Liability

### Workers’ Compensation Statutory

#### Employers’ Liability:

Each Accident	\$100,000
Disease – Each Employee	\$100,000
Disease – Policy Limit	\$500,000

- Policy must contain a waiver of subrogation against the City of Phoenix.
- This requirement does not apply when a contractor or subcontractor is exempt under A.R.S. §23-902(E), **AND** when such contractor or subcontractor executes the appropriate sole proprietor waiver form.

## 7.6. Notice of Cancellation

For each insurance policy required by the insurance provisions of this Contract, the Contractor must provide to the City, within 5 business days of receipt, a notice if a policy is suspended, voided or cancelled for any reason. Such notice must be mailed, emailed, or hand delivered to City of Phoenix, Public Works Department, 200 W. Washington Street, 7th Floor, Phoenix, AZ 85003 OR [pwd.solicitations@phoenix.gov](mailto:pwd.solicitations@phoenix.gov).

## 7.7. Acceptability of Insurers

Insurance is to be placed with insurers duly licensed or authorized to do business in the state of Arizona and with an “A.M. Best” rating of not less than B+ VI. The City in no way warrants that the required minimum insurer rating is sufficient to protect the Contractor from potential insurer insolvency.

## 7.8. Verification of Coverage

Contractor must furnish the City with certificates of insurance (ACORD form or equivalent approved by the City) as required by this Contract. The certificates for each insurance policy are to be signed by a person authorized by that insurer to bind coverage on its behalf.

All certificates and any required endorsements are to be received and approved by the City before work commences. Each insurance policy required by this Contract must be in effect at or prior to commencement of work under this Contract and remain in effect for the duration of the project. Failure to maintain the insurance policies as required by this Contract or to provide evidence of renewal is a material breach of contract. All certificates required by this Contract must be sent directly to [pwd.solicitations@phoenix.gov](mailto:pwd.solicitations@phoenix.gov). The City project/contract number and project

description must be noted on the certificate of insurance. The City reserves the right to review complete copies of all insurance policies required by this Contract at any time. **DO NOT SEND CERTIFICATES OF INSURANCE TO THE CITY'S RISK MANAGEMENT DIVISION.**

## 7.9. Subcontractors

Contractor's certificates shall include all subcontractors as additional insureds under its policies **OR** Contractor shall be responsible for ensuring and verifying that all subcontractors have valid and collectable insurance. At any time throughout the life of the contract, the City of Phoenix reserves the right to require proof from the Contractor that its subcontractors have insurance coverage. All subcontractors providing services included under this Contract's Scope of Services are subject to the insurance coverages identified above and must include the City of Phoenix as an additional insured. In certain circumstances, the Contractor may, on behalf of its subcontractors, waive a specific type of coverage or limit of liability where appropriate to the type of work being performed under the subcontract. Contractor assumes liability for all subcontractors with respect to this Contract.

## 7.10. Approval

Any modification or variation from the insurance coverages and conditions in this Contract must be documented by an executed contract amendment.

## 8. Submittals

### 8.1. Copies

#### **For In-Person and Carrier Delivery**

If submitting a hardcopy offer to the City, please submit one original and one electronic copy (portable thumb drive) of the Submittal Section and addenda(s), if applicable. **Please include updated W-9, a sample invoice, and all other required documentation.**

#### **For Electronic Submittal via email**

If submitting an electronic offer to the City via email, please submit one copy of the Submittal Section and addenda(s), if applicable. **Please include an updated W-9, a sample invoice, and all other required documentation.**

**Please submit only the Submittal Section, do not submit a copy of the entire solicitation document.** This Offer will remain in effect for a period of NO VALUE calendar days from the opening date, and is irrevocable unless it is in the City's best interest to release offer(s).

**Please DO NOT submit links to Google Docs, Dropbox Paper, or similar services. Your offer may be deemed non-responsive if your offer is supplied utilizing these services.**

### 8.2. Solicitation Response Check List

Use this check list as a tool to review your submission to ensure that all required documents and forms are included.

The written offer should be:

- Typewritten for ease of evaluation
- Signed by an authorized representative of the Offeror
- Submitted with contact information for the individual(s) authorized to negotiate with the City
- A. Offeror's Proposal - A detailed proposal describing the firm or individual's qualifications and experience responsive to the requirements of the solicitation and evaluation criteria.
- B. Pricing Proposal - A completed pricing proposal with all requested prices, quantities, and/or discounts completed.
- C. Submittal Forms - All submittal forms are completed and signed.
- D. Addenda - Signed copies of all published addenda.

Offers must be in possession of the Department on or prior to the exact time and date indicated in the Schedule of Events. Late offers will not be considered. Electronic submission is preferred. Due to file size limitations for electronic transmission, offers sent by email may need to be sent in parts with multiple emails. It is the responsibility of the Offeror to ensure that the offer is received timely and that there are no technical reasons for delay. Please refer to the Instructions Section for complete information regarding the submission of offers.



### 8.3. Additional Quantities

The City anticipates considerable activity under the resultant contract(s). However, no guarantee can be made as to actual units, that will be purchased under this contract. The City reserves the right to add, change or delete quantities or items as circumstances may require.



9. EXHIBITS

EXHIBIT A- SIDE DIMENSIONS

CITY OF PHOENIX

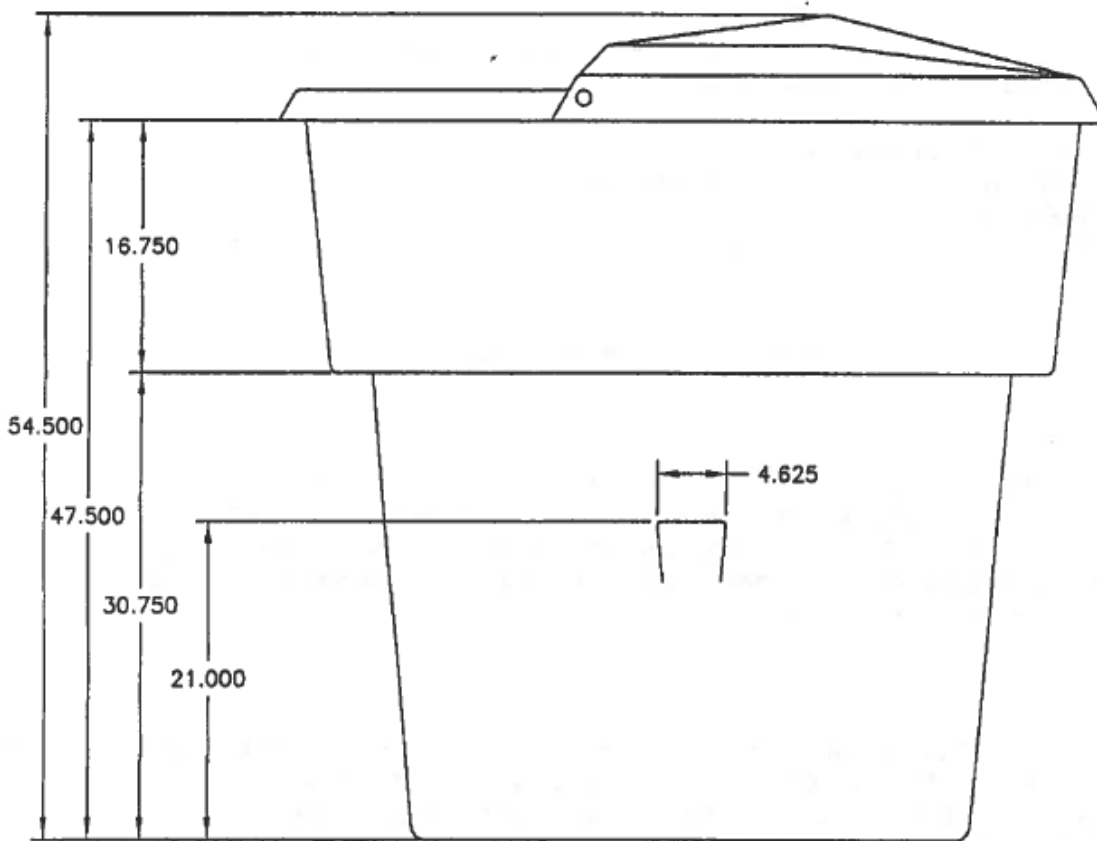

SIDE

RFID

PERMANENT BARCODE (PBC)

5.00"W x 2.50"H

POSITION AS FAR TO THE LEFT AND AS HIGH AS POSSIBLE

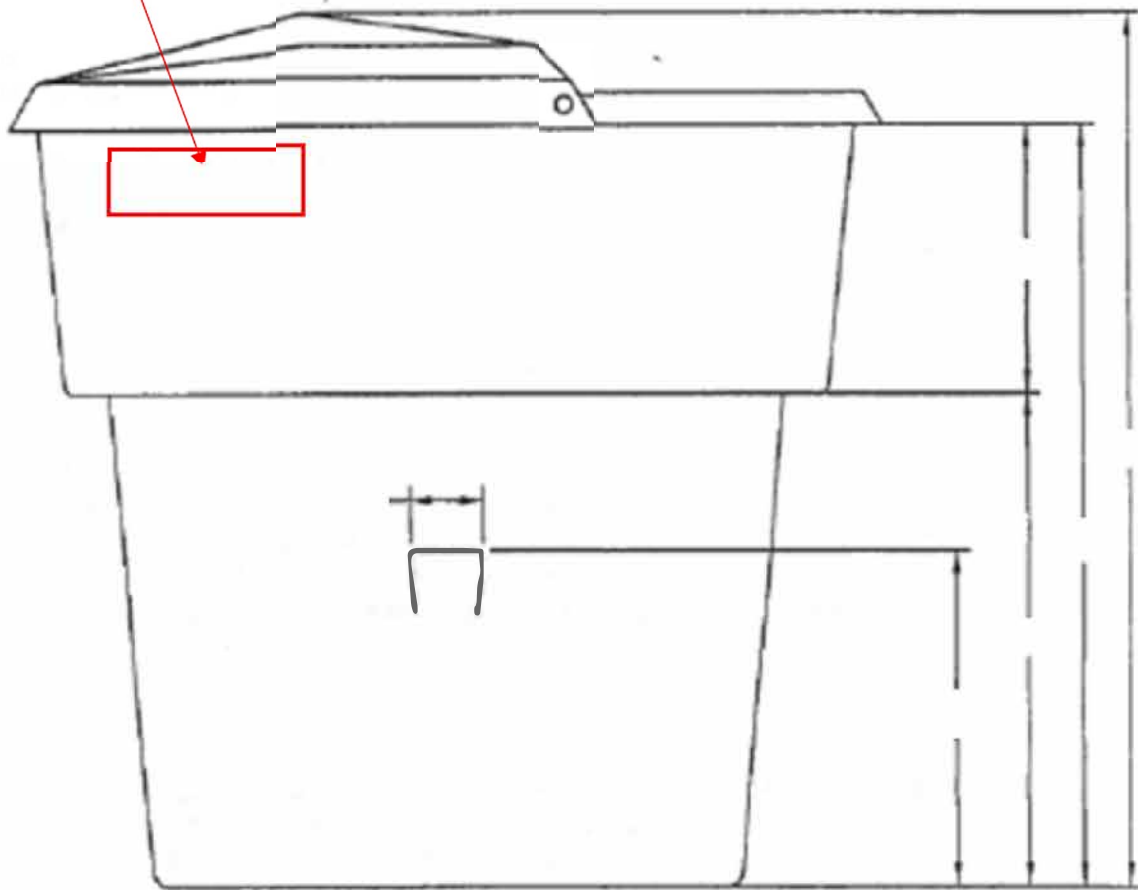
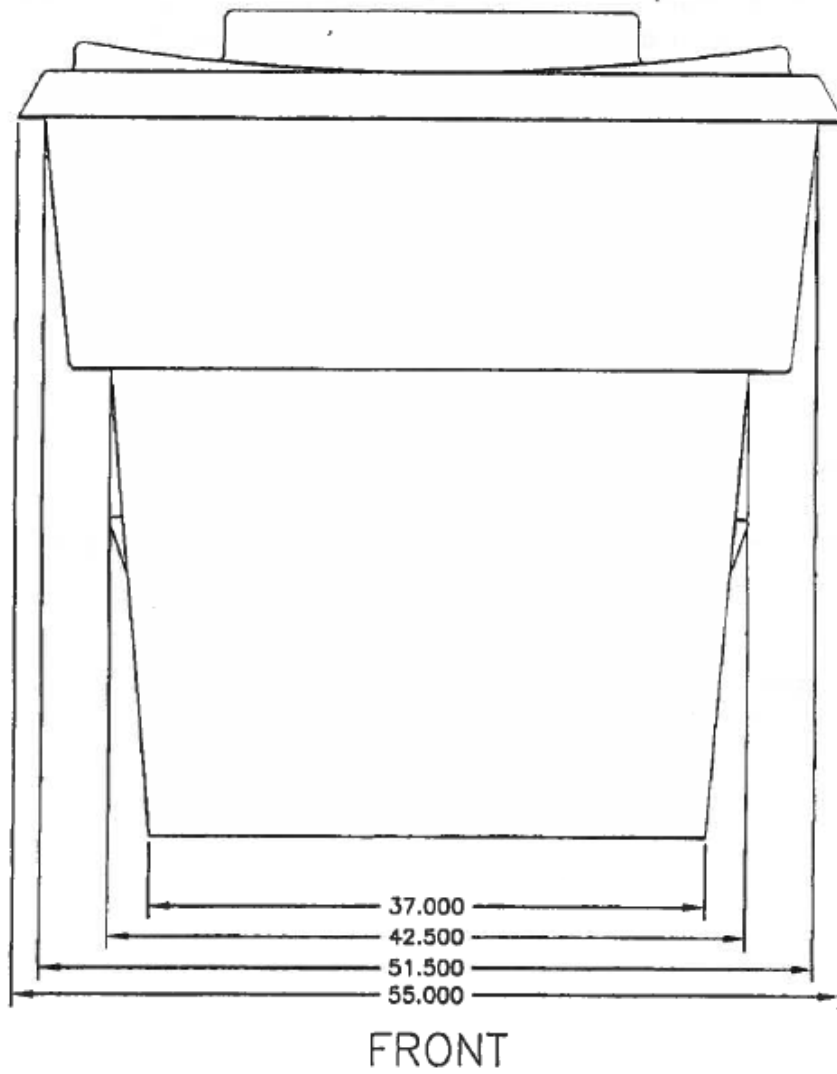



EXHIBIT B - FRONT DIMENSION

CITY OF PHOENIX



# EXHIBIT C - BIN CONTAINER PICTURES

1



2



3

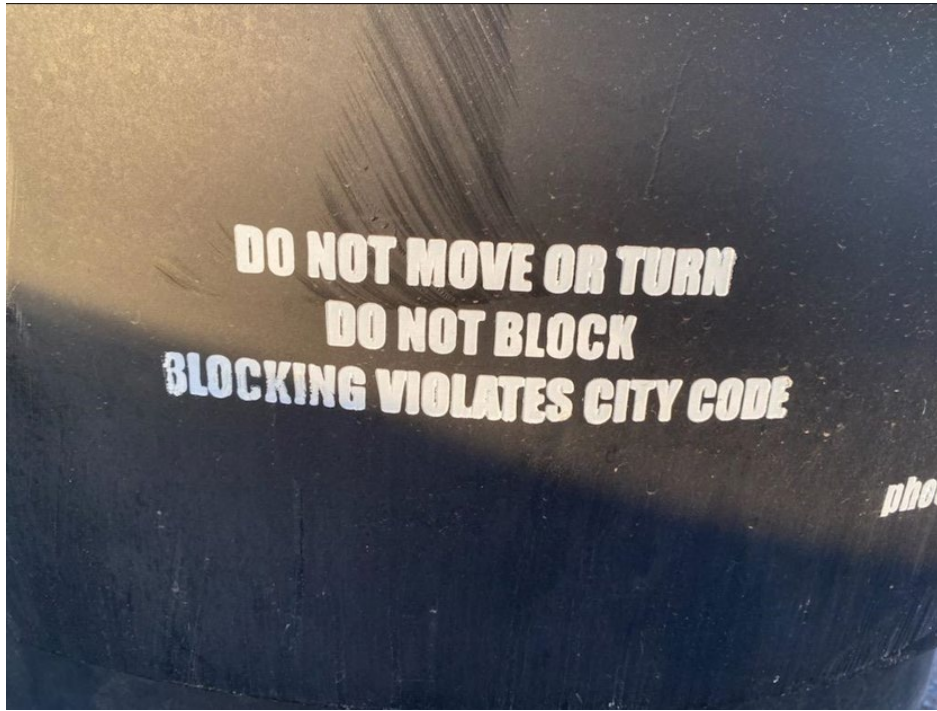

4

